

March 2, 2022

Mr. Bill Sinnott, PE
Senior Engineer
Illinois EPA
BOL, Permit Section #33
1021 North Grand Ave East
Springfield, IL 62794

**Contained-In Determination Request Form
Pretreatment Water Management
Roxana, Illinois
1191150002 - Madison County
Log No. PS22-007**

Dear Mr. Sinnott:

AECOM Technical Services, Inc. (AECOM), on behalf of Equilon Enterprises LLC d/b/a Shell Oil Products US (Shell), previously submitted information requesting a contained-in determination for groundwater generated during upcoming proposed remediation activities at the Roxana Public Works Yard. This submittal is submitting the Contained-In Determination Request Form that was inadvertently left out of the previous submittal (Log No. PS22-007). Also enclosed herein is a full copy of the previous submittal for completeness and reference.

If you have additional questions or comments regarding this information, please do not hesitate to contact me at wendy.pennington@aecom.com or (314) 452-8929.

Sincerely,



Wendy Pennington, PE
Project Manager
AECOM
M: 314-452-8929
E: wendy.pennington@aecom.com

Enclosures: Contained-In Determination Request Form
Contained-In Determination for Pretreatment Water Management (Log No. PS22-007) dated 2/21/22

Cc: Leroy (Buddy) Bealer, SOPUS
Repositories (Roxana website, Roxana Public Library)
Project File

CONTAINED-IN DETERMINATION REQUEST FORM

I. Introduction / Purpose

The owner/ operator identified below requests Illinois EPA's concurrence with their contained-in determination that the soil, subject to this request, contaminated with a listed hazardous waste at their site identified below meets all of the following conditions and therefore, would no longer be considered to contain a listed hazardous waste and may be managed as a non-hazardous waste:

- a. The contaminated soil does not exhibit any of the characteristics of a hazardous waste as set forth in 35 IAC 721, Subpart C,
- b. The contaminated soil meets the land disposal restrictions (LDRs) at 35 IAC 728.149, including the standards for all underlying hazardous constituents (UHCs) that may be present, and
- c. The contaminated soil will be disposed of in a nonhazardous waste landfill permitted under 35 IAC 813 which meets the design requirements at 35 IAC 811, or an on-site nonhazardous waste landfill that meets the design requirements of 35 IAC 811.
- d. The contaminated soil is manifested to the nonhazardous waste landfill as a special waste.

II. Site Identification (type or print)

IEPA Bureau of Land ID No.:	1191150002
Facility Name:	Roxana Public Works Yard Equilon Enterprises LLC d/b/a Shell Oil Products US
Facility Contact Name:	Wendy Pennington (AECOM Technical Services, Inc.)
Street Address:	100 North Broadway, 20 th Floor
City, State, Zip Code:	St. Louis, MO 63102
Latitude:	38.84199
Longitude:	-90.07695
(to five decimal places: 90.12345N, 40.67890W)	
Facility Contact Phone No.:	314-452-8929
Facility Contact E-Mail:	wendy.pennington@aecom.com

III. Owner and Operator Information (type or print)

Site Owner:	Village of Roxana
Owner Contact Name:	Marty Reynolds
Street Address:	310 North Central Ave
City, State, Zip Code:	Roxana, IL 62048
Owner Contact Phone No.:	618-254-0345
Owner Contact E-Mail:	mreynolds@roxana-il.org

Site Operator (if different from owner):	Equilon Enterprises LLC d/b/a Shell Oil Products US
Operator Contact Name:	Leroy (Buddy) Bealer
Street Address:	128 East Center Street
City, State, Zip Code:	Nazareth, PA 18064
Operator Contact Phone No.:	484-632-7955
Operator Contact E-Mail:	leroy.bealer@shell.com

IV. Information Submitted in Support of the "Contained-In Determination"

The following information must be attached to this form:

- a. A brief history of the site and its previous operations, whether it is enrolled in the Site Remediation Program (SRP), and the reason for the Contained-In Determination request. [See Letter dated February 21, 2022 (PS22-007)]
- b. A description of the remediation activities at the site, and provide an estimate of the amount (cubic yards) of contaminated soil that is the subject of this request. [See Letter dated February 21, 2022 (PS22-007)]
- c. An identification of the process/source of the listed hazardous waste(s) generated or managed at the facility and all applicable hazardous waste codes. [See Letter dated February 21, 2022 (PS22-007)]
- d. Analytical results demonstrating that the contaminated soil to be shipped to the non-hazardous waste landfill does not exhibit a characteristic of a hazardous waste, and meets the Land Disposal Restrictions (LDRs) at 35 IAC 728.149, including the standards for all underlying hazardous constituents (UHCs) that may be present. [See Letter dated February 21, 2022 (PS22-007)]
- e. A scaled drawing of the facility showing all structures, the extent of the contaminated soil subject to this request, sample locations (and depths) that are representative of the contaminated soil that is subject of this request. [See Letter dated February 21, 2022 (PS22-007)]

The above information should be provided in a logical and organized fashion. Please identify the attachment number where the information addressing each item above is presented.

V. Signatures

Certification Statement

I certify under penalty of law that this document and all attachments were prepared under my direction or supervision in accordance with a system designed to assure that qualified personnel properly gather and evaluate the information submitted. Based on my inquiry of the person or persons that manage the system, or those persons directly responsible for gathering the information, the information submitted is, to the best of my knowledge and belief, true, accurate, and complete. I am aware that there are significant penalties for submitting false information, including the possibility of fine and imprisonment for knowing violations.

Any person who knowingly makes a false, fictitious, or fraudulent material statement, orally or in writing to the Illinois EPA commits a Class 4 felony. A second or subsequent offense after conviction is a Class 3 felony. (415 ILCS 5/44(h))

Signature of Owner or Operator of Facility

Signature: _____ Date: 2/25/2022

Print/Type Name: Leroy Bealer

Print/Type Title: Senior Program Manager

___ Owner, or X Operator. (check one)

(last revised 11-8-2019)



AECOM
100 North Broadway
20th Floor
St. Louis, MO 63102
aecom.com

February 21, 2021

Mr. Rob Watson, PE
Senior Engineer
Illinois EPA
BOL, Permit Section #33
1021 North Grand Ave East
Springfield, IL 62702

**Contained-In Determination
Pretreatment Water Management
Roxana, Illinois
1191150002 - Madison County
Log No. B-34R**

Dear Mr. Watson:

AECOM Technical Services, Inc. (AECOM), on behalf of Equilon Enterprises LLC d/b/a Shell Oil Products US (SOPUS), is submitting a determination that environmental media generated during remediation activities at the Roxana Public Works Yard (Site) may not contain hazardous waste.

EPA's "contained-in" policy states that contaminated environmental media is subject to all applicable RCRA requirements until they no longer contain hazardous waste. EPA considers contaminated environmental media to no longer contain hazardous waste when:

- It no longer exhibits a characteristic of hazardous waste, or
- Concentrations of listed hazardous waste are below health-based levels.

Once these requirements are met, the environmental media is not subject to RCRA requirements. The groundwater generated at the Site during operation of the proposed Steam Enhanced Extraction (SEE) system is expected to meet these criteria after treatment in the proposed SEE's system groundwater treatment unit. Therefore, AECOM believes the environmental media will no longer contain hazardous waste after treatment.

The following paragraphs provide further information:

Name, address, phone number of property owner

The Site is located south of East 8th Street between Chaffer Avenue and Old Edwardsville Road in Roxana, Illinois. The Site is owned by the Village of Roxana:

Marty Reynolds, Mayor
Village of Roxana
143 East 8th Street
Roxana, IL 62084
618-254-1951

Name, address, phone number of operator (if different than owner)

AECOM, on behalf of SOPUS, will be the operator of the proposed SEE system at the Site. Contact information is presented below:

Mr. Leroy (Buddy) Bealer
Principal Program Manager
Shell Oil Products US
128 East Center St
Nazareth, PA 18064
(484) 632-7955

Mrs. Wendy Pennington
Project Manager
AECOM
100 North Broadway
20th Floor
St. Louis, MO 63102
314-452-8929

Facility name and Bureau of Land ID number for the site

Roxana Public Works Yard

BOL ID# 1191150002

Brief history of the site and its previous operations, whether it is enrolled in the Site Remediation Program (SRP), and the reason for the Contained-In Determination request

The Site is located to the east of a 1986 benzene pipeline release located northwest of the intersection of Rand Avenue and Route 111, and to the west of the Wood River Refinery (WRR) North Property West Fenceline. The Site is managed under the Corrective Action section of the SOPUS RCRA Part B Hazardous Waste Post-Closure Permit at the Wood River Refinery (Permit) most recently modified December 20, 2019. The Site is not enrolled in the SRP.

The Roxana Public Works Yard occupies approximately 2.4 acres, where approximately 0.4 acres is covered or obstructed by buildings and/or structures. Topographically, the western and southern portions of the Site are at a lower elevation relative to the northeastern portion, with a relief of approximately 13 feet. The Site is infrequently used by the Village of Roxana for vehicle maintenance and storage. Most of the Site is enclosed by a chain link fence.

AECOM, on behalf of SOPUS, has conducted several subsurface investigations at the Public Works Yard and began quarterly groundwater monitoring in 2010. These investigations indicated dissolved-phase benzene concentrations ranging from 100 mg/L to 1,900 mg/L. In 2011, a Soil Vapor Extraction (SVE) system compound was constructed on the neighboring WRR North Property, which includes a header-line connecting to six extraction wells at the Site. There are also eight multilevel vapor monitoring points (VMPs) and two groundwater monitoring wells at the Site. The SVE system has operated at the Site since late 2012. Soil vapor data from the Site demonstrates the shallow and intermediate zones have been remediated. Deep (>25 feet below ground surface) soil gas concentrations have also decreased over time but remain elevated in some areas with fluctuating groundwater levels and submerged impacts. The proposed SEE system at the Site is utilizing a more aggressive remedial technology to reduce the highest benzene concentrations observed at the Site.

AECOM is requesting that IEPA concur with this "contained-in" determination so the groundwater generated from the proposed SEE system can be managed as nonhazardous waste and treated at a nearby publicly owned treatment works (POTW).

Description of remediation activities at the site, the units involved, how they are regulated, and an estimate of the amount (gallons) and generation rate of contaminated water that is the subject of this request

The Steam Enhanced Extraction system can be broken down into three parts: a steam injection system, a multiphase extraction system, and a water treatment system.

The steam injection portion of the system will consist of a steam boiler fed by natural gas meant to convert potable water to steam. Steam will be heated to temperatures that exceed the minimum required temperature to volatilize the constituent of concern (benzene) and will be injected via a network of wells spaced on 30-foot centers within the treatment areas.

The multiphase extraction system will extract both liquid and vapor from the treatment areas, where the two phases will be separated, managed, and treated separately. Upon initial extraction, the combined vapor and liquid stream will pass through a 5,000-gallon silt/liquid/vapor knockout tank to separate liquids from vapors. Vapors will then pass through two additional knockouts before being directed to the existing regenerative thermal oxidizer (RTO) located on the adjacent Phillips 66 Wood River Refinery property. Should the RTO experience an upset condition (i.e., power outage), the vapor stream will be directed to two 2,500-lbs sacrificial vapor granular-activated carbon vessels. The

liquid stream will pass through an oil-water separator where any NAPL will be segregated and containerized before the liquid phase passes through an air-stripper. All vapors stripped from the liquid phase at this point will pass through another knockout before combining with the vapor stream being directed to the RTO.

The water treatment portion of the system begins with the aforementioned air-stripper where the liquid phase will then pass through six sets of bag filters, ending with two 2,000 lb liquid-phase activated carbon treatment vessels before it is pumped into a 5,000-gallon storage tank that will then discharge to the Roxana POTW.

It is anticipated that a total 6.8 million gallons of water will be extracted and treated over the duration of the SEE project. This equates to an average of 26 gallons per minute of treated water discharge, given the projected 180 day run time of the SEE system.

Identification of the process/source of the listed hazardous waste(s) generated or managed at the facility and all applicable hazardous waste codes

Since the environmental media contains benzene that potentially originated from a commercial product benzene release, the media (groundwater) may be classified with a U019 listed hazardous waste code with a Land Disposal Restriction (LDR) of 0.14 mg/L. Benzene concentrations contained in the media may exceed 0.5 mg/L, which would cause the media to be a characteristically hazardous waste with a D018 characteristically hazardous waste toxicity code.

Analytical results, or a commitment, that demonstrates the wastewater going to the POTW meets the following conditions: (1) does not exhibit a characteristic of a hazardous waste; (2) meets the LDR at 35 IAC 728 including standards for all underlying hazardous constituents (UHCs) that may be present, and (3) meets the pre-treatment standards for the POTW

Extracted groundwater will be separated from the vapor stream via a knockout prior to being pumped to an oil-water separator, where any NAPL will be segregated. Liquids will then be passed through the following in the order listed: an air-stripper, three pairs of bag filters, and then two 2,000 lb liquid-phase activated carbon treatment vessels. Treated water will then be pumped into a 5,000-gallon equalization tank from which the water can be sampled prior to discharge.

After treatment, the collected groundwater will be analyzed for benzene (constituent of primary concern). If the benzene concentrations in the treated groundwater meet the criterion in Table 1 below, the groundwater will be considered to no longer contain hazardous waste. AECOM will regularly analyze treated groundwater to demonstrate continued effectiveness in meeting the criteria outlined in Table 1 below.

Constituent	Criterion	Source/Logic
Benzene	0.14 mg/L	35 IAC 728 LDR; also satisfies 0.5 mg/L hazardous waste characterization threshold

Scaled drawing of the facility showing all structures, extent of contaminated groundwater subject to this request, sample locations (and depths) that are representative of the contaminated groundwater that is subject to this request

The contaminated groundwater will be extracted by the proposed SEE system from wells screened from 24 to 57 feet below ground surface in the permeable Main Sand aquifer. The locations of the wells are shown on the attached *system layout figure*. The primary zone of impact and focus area for the thermal treatment is located from 34 to 54 feet below ground surface. No groundwater samples will be collected from the Site during active remediation due to safety concerns. Extracted groundwater will be sampled regularly from the 5,000-gallon holding tank, to make sure the water treatment is continually efficient. See the attached figures for SEE system well field layout, well completion drawings, well head construction details, process flow diagram, and process and instrumentation diagram.

See the attached *Wastewater Treatment Plant Capacity Increase Village of Roxana* for the existing features currently on the Roxana Public Works Yard Site.

Scaled drawing of the POTW showing all structures, units, property line, and location where the wastewater will be discharged to the POTW

Please see the attached *Wastewater Treatment Plant Chemical Feed Improvements Village of Roxana* for a Scaled Drawing of the Roxana, Illinois POTW.

Verification that the POTW currently has a USEPA approved pretreatment program (including when program was approved)

The Roxana POTW does not currently have any influent pretreatment standards. They primarily process leachate from the local landfill. The Roxana POTW operates under NPDES Permit IL-0077356. The Village of Roxana is currently working on passing a wastewater treatment ordinance.

If you have additional questions or comments regarding this information, please do not hesitate to contact me at wendy.pennington@aecom.com or (314) 452-8929.

Sincerely,



Wendy Pennington, PE
Project Manager
AECOM
M: 314-452-8929
E: wendy.pennington@aecom.com

Enclosures: Figures to support above information

Cc: Leroy (Buddy) Bealer, SOPUS
 Repositories (Roxana website, Roxana Public Library)
 Project File

LEGEND

- PIPE RACK
- TREATMENT SYSTEM PIPING
- MULTIPHASE EXTRACTION PIPING
- THERMAL INFLUENCE BOUNDARY
- + NORFOLK SOUTHERN RAILROAD
- STEAM INJECTION POINT
- ⊗ MULTIPHASE EXTRACTION WELL
- ⊗ TEMPERATURE SENSOR
- STEAM TRAP

EIGHTH ST

CHAFFER AVE

Area A

Area B

Approximate Location of Power and Water Utility Connections

PDP

Power Distribution Panel

Equipment Staging Area

FILE: G:\ST.LOUIS\DESIGN\PROJECTS\DATA\BUELL\02482794.ROXANA.2018\000_DELIVERABLES\DELIV\DATA_CAD\WORKPLAN\WORKPLAN_PUBLIC_WORKS_YARD.dwg (DWG) 10/11/2018 10:08:28 a.m. by: wendy.gavin@agm.com

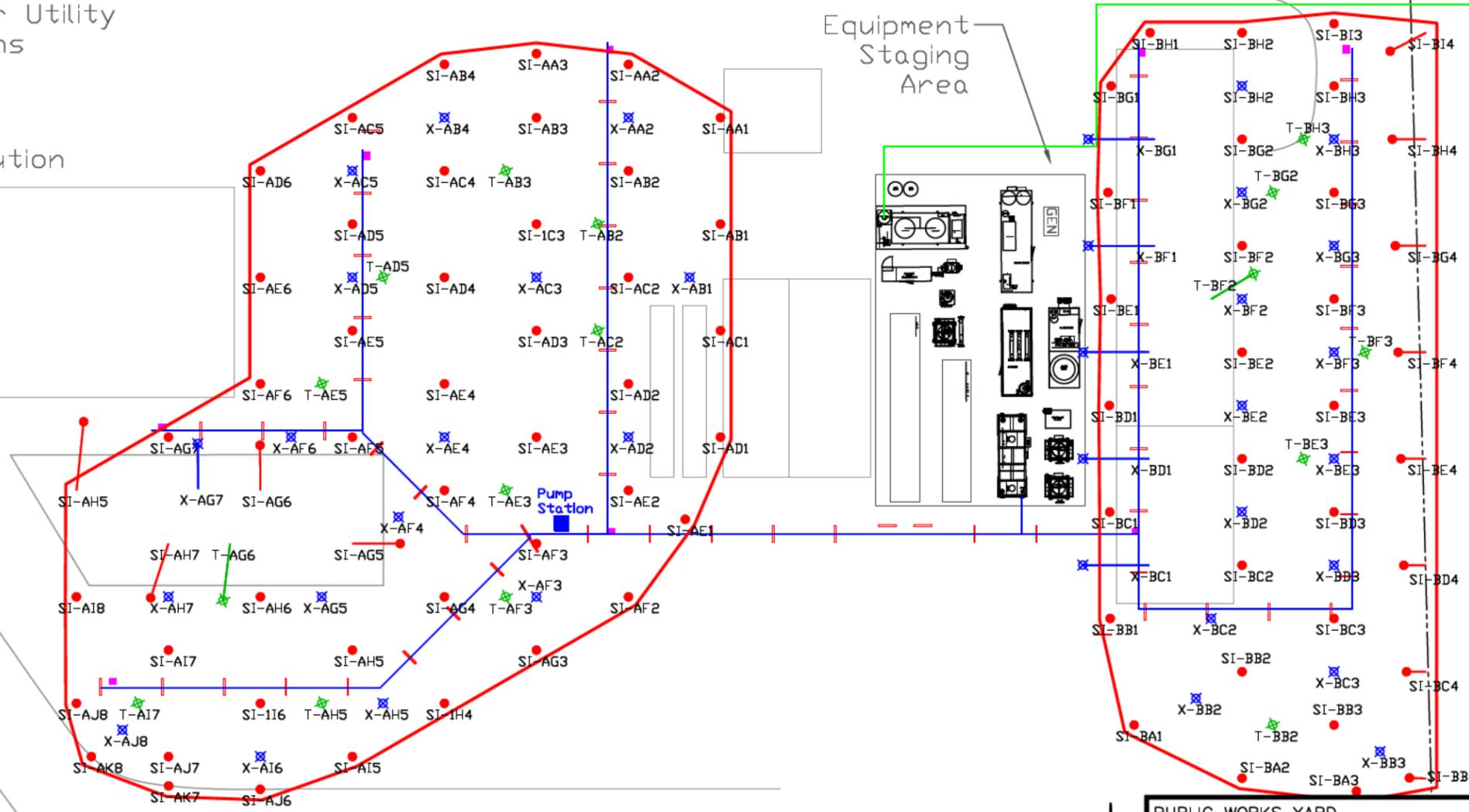

PUBLIC WORKS YARD STEAM ENHANCED EXTRACTION WORKPLAN ROXANA, ILLINOIS		PROJECT NO. 60648474
AECOM		
DRN. BY: bah Dec 2021 DSGN. BY: djd CHKD. BY: wmp	Steam Enhanced Extraction System Layout	FIG. NO. 2

AREA A

DIGITAM™ TEMPERATURE SENSOR WELL QUANTITY - 9

STEAM INJECTION WELL QUANTITY - 44

MULTIPHASE EXTRACTION WELL QUANTITY - 16

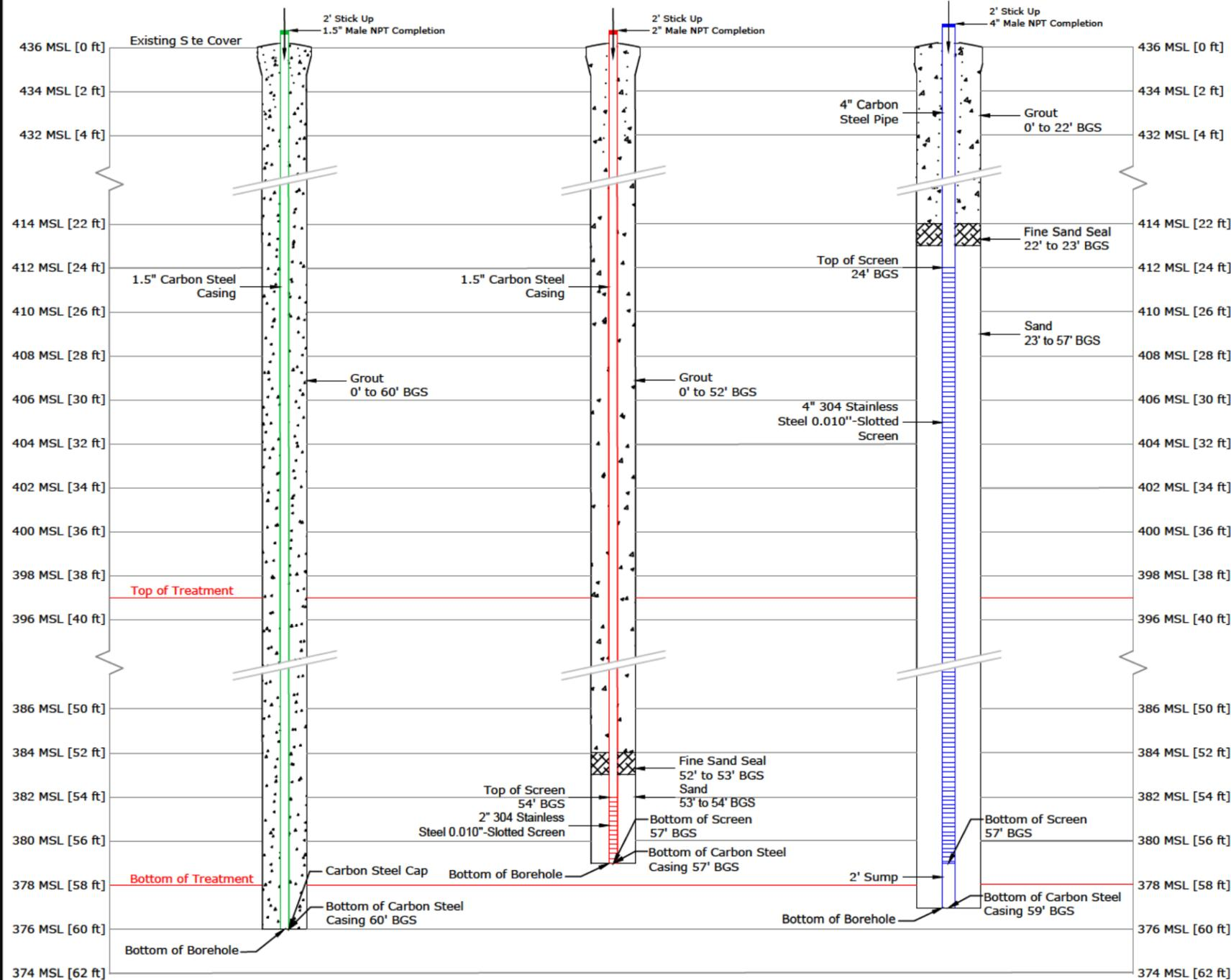

GENERAL NOTES:

1. MATERIAL TYPES
 - A. GROUT
 - HIGH TEMPERATURE PORTLAND TYPE 1 OR EQUIVALENT (NO BENTONITE)
 - B. SAND
 - FINE SAND SEAL: 40/60 SILICA SAND
 - STEAM INJECTION/EXTRACTION WELLS: 20/40 SILICA SAND
2. STEAM INJECTION WELLS
 - A. MINIMUM 4" DIAMETER BOREHOLE
 - B. 2" SCHEDULE 40 CARBON STEEL CASING
 - C. NOMINAL 2" DIAMETER WIRE-WRAPPED 304 STAINLESS STEEL 0.010"-SLOTTED SCREEN
3. TEMPERATURE WELLS
 - A. MINIMUM 4" DIAMETER BOREHOLE
 - B. 1.5" SCHEDULE 40 CARBON STEEL CASING
 - C. THREADS CAN BE NPT OR FLUSH JOINT
 - D. STICKUP MUST BE MALE NPT
 - E. ALL JOINTS TO BE TIGHTENED WITH PIPE WRENCH USING PIPE THREAD COMPOUND AND PTFE TAPE
4. MULTIPHASE EXTRACTION WELLS
 - A. MINIMUM 8" DIAMETER BOREHOLE
 - B. 4" SCHEDULE 40 CASING
 - C. NOMINAL 4" DIAMETER WIRE-WRAPPED 304 STAINLESS STEEL 0.010"-SLOTTED SCREEN
 - D. FITTINGS BETWEEN PIPE SECTIONS ARE 4 THREAD PER INCH (TPI) FLUSH THREADED UNLESS SPECIFIED OTHERWISE (IE M NPT OR PLUG)
 - E. 4" NPT FEMALE X WELD PLATE ENDS



McMILLAN-McGEE CORP.
ELECTROMAGNETIC SYSTEMS AND SERVICES
FOR THE ENERGY AND ENVIRONMENTAL INDUSTRIES
4895 - 358 STREET SE
CALGARY, AB T2B 3M9 CANADA
WWW.McMILLAN-McGEE.COM
PH: 403.569.5100, FX: 403.272.7201

REV.	DATE	DESCRIPTION	DRAWN BY	CHKD BY	APPROVED BY
B2	2021/09/28	90% DESIGN	JS	CC	CC
B1	2021/08/27	60% DESIGN	JS	CC	CC
A1	2021/08/20	NOT FOR CONSTRUCTION	CC	CC	-
REV.	DATE	DESCRIPTION	DRAWN BY	CHKD BY	APPROVED BY
(YRMMDD)					

APEGA PERMIT NUMBER: P09173
SCALE: NOT TO SCALE

TITLE: **ET-DSP™ Well Completion Drawing**
CLIENT: **AECOM**

PROJECT: **Roxana Public Works Yard
Roxana, Illinois**

SHEET: **WCD-01**

AREA B

DIGITAM™ TEMPERATURE SENSOR WELL QUANTITY - 5

STEAM INJECTION WELL QUANTITY - 31

MULTIPHASE EXTRACTION WELL QUANTITY - 12

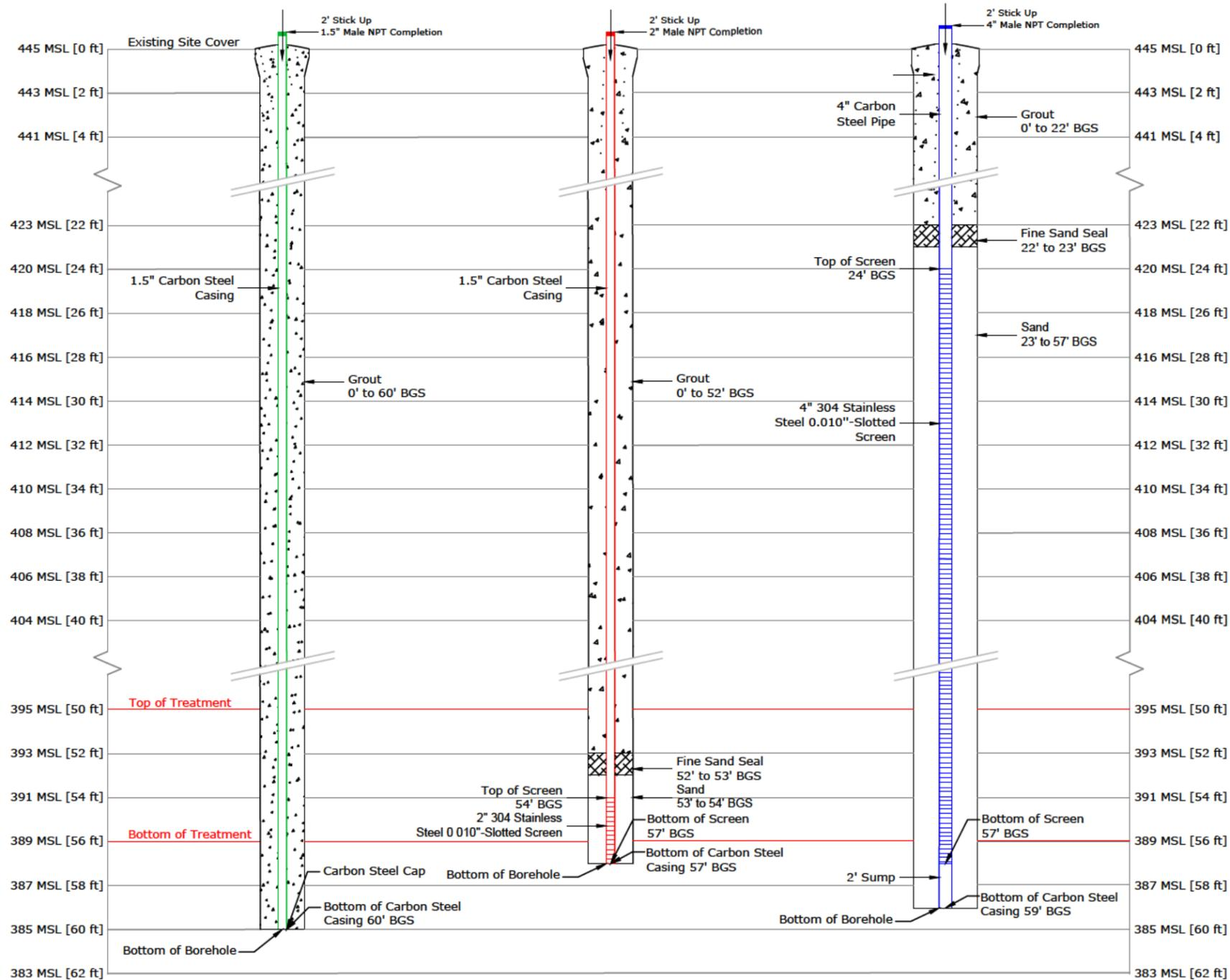

GENERAL NOTES:

1. MATERIAL TYPES
 - A. GROUT
 - HIGH TEMPERATURE PORTLAND TYPE 1 OR EQUIVALENT (NO BENTONITE)
 - B. SAND
 - FINE SAND SEAL: 40/60 SILICA SAND
 - STEAM INJECTION/EXTRACTION WELLS: 20/40 SILICA SAND
2. STEAM INJECTION WELLS
 - A. MINIMUM 4" DIAMETER BOREHOLE
 - B. 2" SCHEDULE 40 CARBON STEEL CASING
 - C. NOMINAL 2" DIAMETER WIRE-WRAPPED 304 STAINLESS STEEL 0.010"-SLOTTED SCREEN
3. TEMPERATURE WELLS
 - A. MINIMUM 4" DIAMETER BOREHOLE
 - B. 1.5" SCHEDULE 40 CARBON STEEL CASING
 - C. THREADS CAN BE NPT OR FLUSH JOINT
 - D. STICKUP MUST BE MALE NPT
 - E. ALL JOINTS TO BE TIGHTENED WITH PIPE WRENCH USING PIPE THREAD COMPOUND AND PTFE TAPE
4. MULTIPHASE EXTRACTION WELLS
 - A. MINIMUM 8" DIAMETER BOREHOLE
 - B. 4" SCHEDULE 40 CASING
 - C. NOMINAL 4" DIAMETER WIRE-WRAPPED 304 STAINLESS STEEL 0.010"-SLOTTED SCREEN
 - D. FITTINGS BETWEEN PIPE SECTIONS ARE 4 THREAD PER INCH (TPI) FLUSH THREADED UNLESS SPECIFIED OTHERWISE (IE M NPT OR PLUG)
 - E. 4" NPT FEMALE X WELD PLATE ENDS



McMILLAN-McGEE CORP.
ELECTROMAGNETIC SYSTEMS AND SERVICES
FOR THE ENERGY AND ENVIRONMENTAL INDUSTRIES
4895 - 358 STREET SE
CALGARY, AB T2B 3M9 CANADA
WWW.McMILLAN-McGEE.COM
PH: 403.569.5100, FX: 403.272.7201

REV.	DATE	DESCRIPTION	DRAWN BY	ORG/ENGR	APPROVED BY	SCALE
B2	2021/09/28	90% DESIGN	JS	CC	CC	
B1	2021/08/27	60% DESIGN	JS	CC	CC	
A1	2014/05/13	NOT FOR CONSTRUCTION	CC	CC	-	
DATE: _____						
APEGA PERMIT NUMBER: P09173						

TITLE: **ET-DSP™ Well Completion Drawing**

CLIENT: **AECOM**

PROJECT: **Roxana Public Works Yard
Roxana, Illinois**

SHEET: **WCD-02**

**ANGLED
STEAM INJECTION WELL
QUANTITY - 4**

**ANGLED DIGITAM™
TEMPERATURE SENSOR
WELL
QUANTITY - 2**

**ANGLED MULTIPHASE
EXTRACTION WELL
QUANTITY - 6**

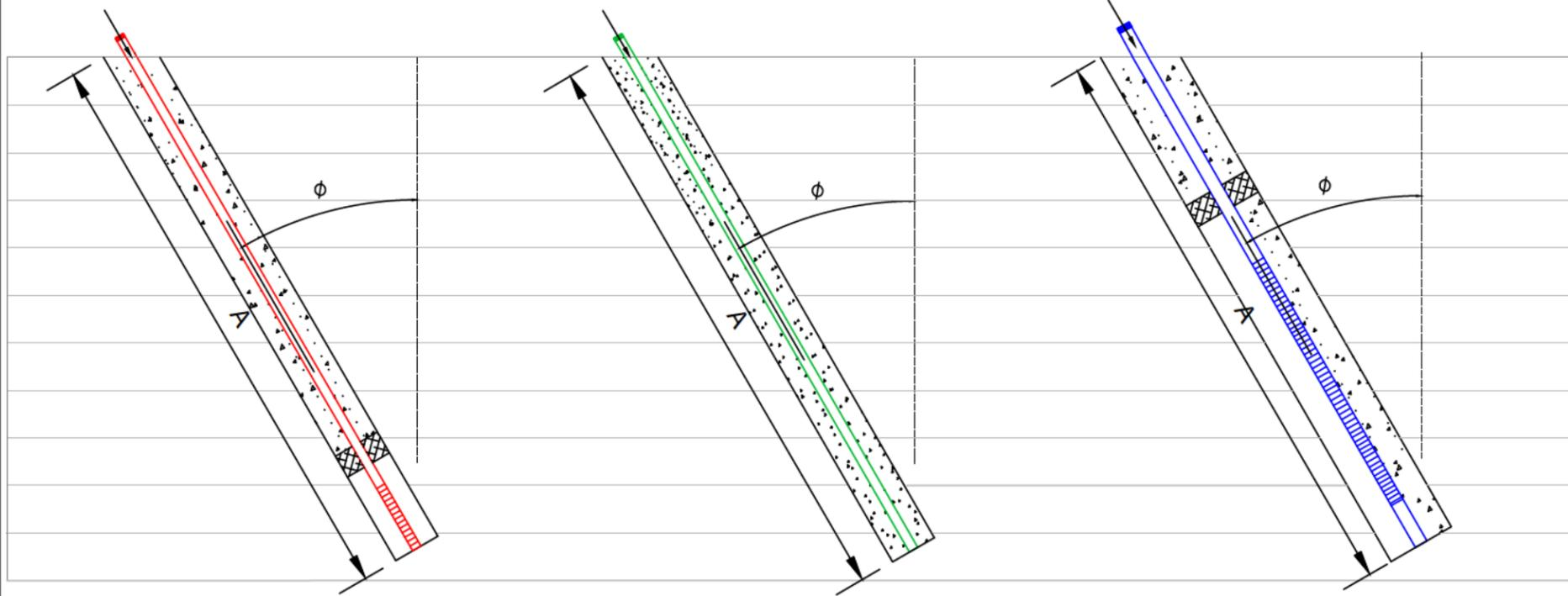

GENERAL NOTES:

1. MATERIAL TYPES
 - A. GROUT
 - HIGH TEMPERATURE PORTLAND TYPE 1 OR EQUIVALENT (NO BENTONITE)
 - B. SAND
 - FINE SAND SEAL: 40/60 SILICA SAND
 - STEAM INJECTION/EXTRACTION WELLS: 20/40 SILICA SAND
2. STEAM INJECTION WELLS
 - A. MINIMUM 4" DIAMETER BOREHOLE
 - B. 2" SCHEDULE 40 CARBON STEEL CASING
 - C. NOMINAL 2" DIAMETER WIRE-WRAPPED 304 STAINLESS STEEL 0.010"-SLOTTED SCREEN
3. TEMPERATURE WELLS
 - A. MINIMUM 4" DIAMETER BOREHOLE
 - B. 1.5" SCHEDULE 40 CARBON STEEL CASING
 - C. THREADS CAN BE NPT OR FLUSH JOINT
 - D. STICKUP MUST BE MALE NPT
 - E. ALL JOINTS TO BE TIGHTENED WITH PIPE WRENCH USING PIPE THREAD COMPOUND AND PTFE TAPE
4. MULTIPHASE EXTRACTION WELLS
 - A. MINIMUM 8" DIAMETER BOREHOLE
 - B. 4" SCHEDULE 40 CASING
 - C. NOMINAL 4" DIAMETER WIRE-WRAPPED 304 STAINLESS STEEL 0.010"-SLOTTED SCREEN
 - D. FITTINGS BETWEEN PIPE SECTIONS ARE 4 THREAD PER INCH (TPI) FLUSH THREADED UNLESS SPECIFIED OTHERWISE (IE M NPT OR PLUG)
 - E. 4" NPT FEMALE X WELD PLATE ENDS

ANGLED WELL DETAILS

Well	φ	A	Well	φ	A
SI-AH5	18.83	60.22	X-BD1	17.63	61.90
SI-AH7	15.73	59.21	X-BE1	17.63	61.90
SI-AG6	12.56	58.39	X-BF1	17.63	61.90
SI-AG5	13.30	58.57	X-BG1	17.63	61.90
X-AG7	12.15	60.35	T-AG6	15.34	62.21
X-BC1	17.63	61.90	T-BF2	20.24	63.00



MCMILLAN-MCGEE CORP.
ELECTROMAGNETIC SYSTEMS AND SERVICES
FOR THE ENERGY AND ENVIRONMENTAL INDUSTRIES
4895 - 358 STREET SE
CALGARY, AB T2B 3M9 CANADA
WWW.MCMILLAN-MCGEE.COM
PH: 403.569.5100, FX: 403.272.7201

REV.	DATE	DESCRIPTION	DRAWN BY	CHKD BY	APPROVED BY
B2	2021/09/28	90% DESIGN	JS	CC	CC
B1	2021/08/20	60% DESIGN	JS	CC	CC
DATE: _____					
APEGA PERMIT NUMBER: P09173					
SCALE: NOT TO SCALE					

TITLE: **ET-DSP™ Well Completion Drawing**
CLIENT: **AECOM**

PROJECT: **Roxana Public Works Yard
Roxana, Illinois**

SHEET: **WCD-03**

MULTIPHASE EXTRACTION WELL WITH DOWNHOLE PUMP

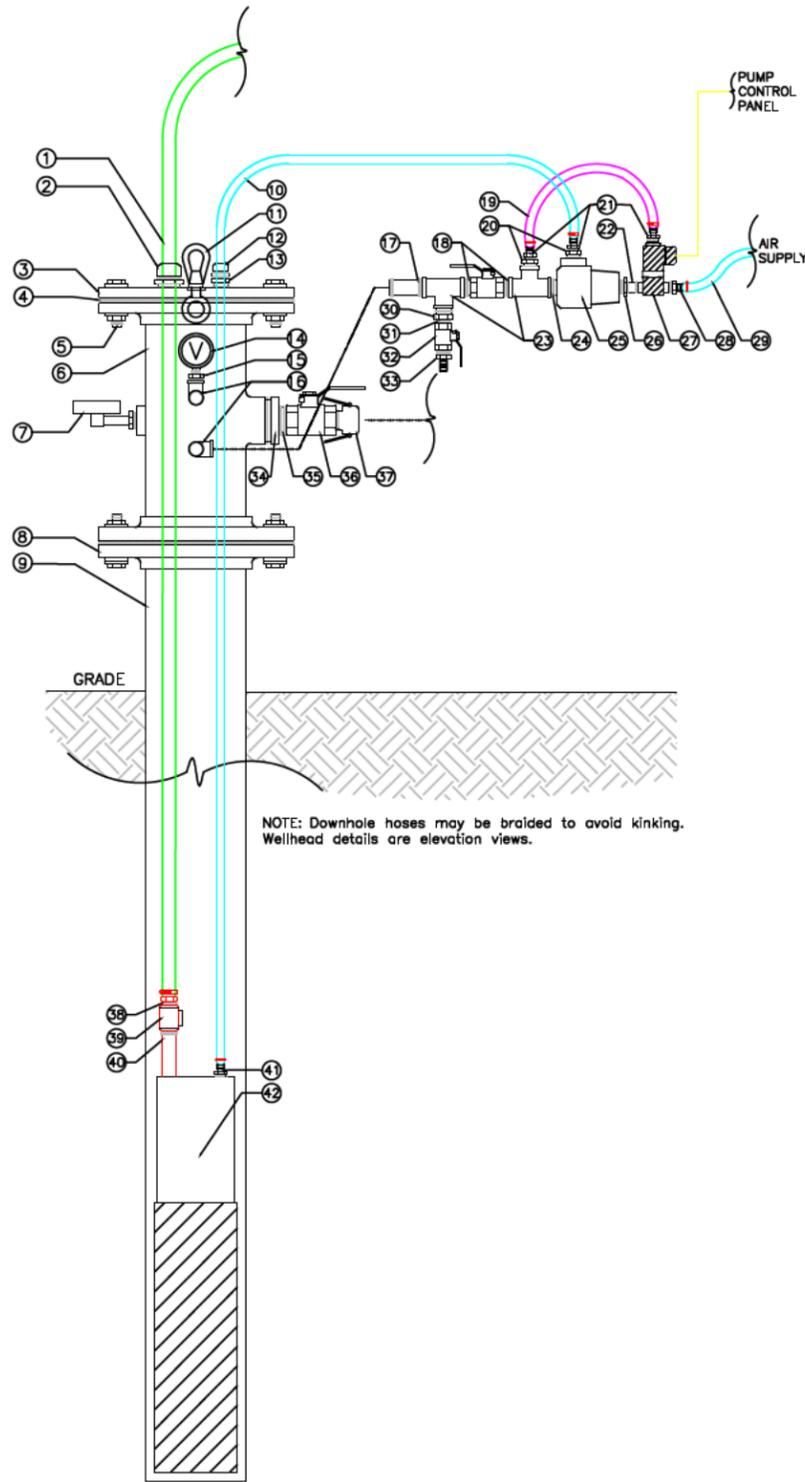

WELLHEAD COMPONENTS

1. 1/2" ID PTFE GROUNDWATER EXTRACTION LINE
2. 1/2" X 3/4" M NPT CORD GRIP, PVDF
3. 4" Ø 150# WELL COVER PLATE, STEEL
4. 4" Ø 150# X 1/8" GASKET, VITON (TYP.)
5. 5/8" BOLT, LOCK WASHER & HEX NUT, ZINC (TYP.)
6. 4" Ø Mc² WELLHEAD X 150# FLANGE ENDS, STEEL
7. TEMPERATURE GAUGE 0-250°F X 1/2" M NPT
8. 4" Ø 150# FLANGE X 4" F NPT, STEEL
9. 4" Ø M NPT RISER STICKUP, CARBON STEEL
10. 1/4" ID PTFE COMPRESSED AIR HOSE
11. 1/2" LIFTING EYE ASSEMBLY, WITH GASKET
12. 3/8" X 1/2" M NPT CORD GRIP, PVDF
13. 3/4" M NPT X 1/2" F NPT BUSHING, GALV.
14. VACUUM GAUGE, 0-30" HG X 1/4" M NPT
15. 1/2" M NPT X 1/4" F NPT BUSHING, BRASS
16. 1/2" NPT STREET ELBOW, BRASS
17. 1/2" X 3" NIPPLE, GALV.
18. 1/2" NPT CLOSE NIPPLE, GALV.
19. 1/4" ID ORTAC VENT HOSE
20. 1/2" M NPT X 1/4" F NPT BUSHING, BRASS
21. 1/4" M NPT X 1/4" HOSE BARB, BRASS
22. 1/4" X 3" NIPPLE, GALV.
23. 1/2" NPT PIPE TEE, GALV.
24. 1/2" NPT CLOSE NIPPLE, GALV.
25. 1/2" SUPER QUICK EXHAUST VALVE
26. 1/2" M NPT X 1/4" F NPT BUSHING, BRASS
27. 1/4" 3-WAY SOLENOID VALVE
28. 1/4" M NPT X 1/4" HOSE BARB, BRASS
29. 1/4" ID ORTAC COMPRESSED AIR HOSE
30. 1/2" M NPT X 3/8" F NPT BUSHING, GALV.
31. 3/8" NPT CLOSE NIPPLE, BRASS
32. 3/8" NPT BALL VALVE, BRASS
33. 3/8" M NPT X 1/4" HOSE BARB, BRASS
34. 2" M NPT X 1-1/2" F NPT REDUCER BUSHING, GALV.
35. 1-1/2" NPT CLOSE NIPPLE, GALV.
36. 1-1/2" NPT BALL VALVE, BRASS
37. 1-1/2" M NPT X 1-1/2" FEMALE CAMLOCK (PART B), ALUM. ALLOY
38. 1/2" M NPT X 3/4" HOSE BARB, BRASS
39. 3/4" SWING CHECK VALVE, BRASS
40. 3/4" X 6" NIPPLE, GALV.
41. 1/4" M NPT X 1/4" HOSE BARB, BRASS
42. PNEUMATIC PUMP WITH TOP-LOADING CUP ADAPTER

MULTIPHASE EXTRACTION WELL CONNECTION TO CONVEYANCE PIPING NETWORK

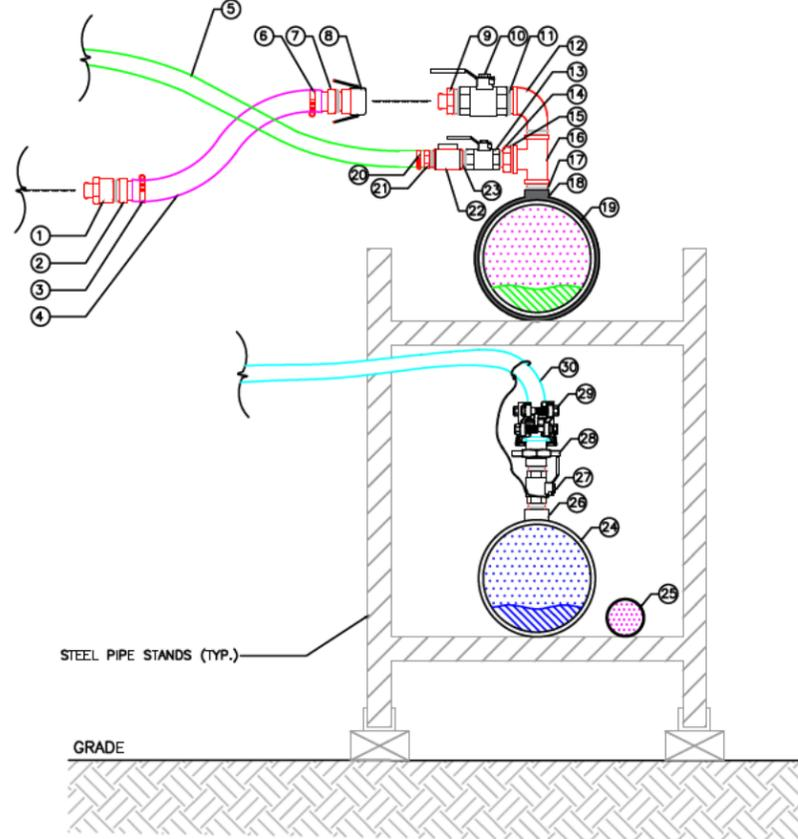

PIPING CONNECTION COMPONENTS

1. 1-1/2" M CAMLOCK TO 1-1/2" F NPT (PART A), ALUM. ALLOY
2. 1-1/2" M NPT TO X 1-1/2" PEX BARB
3. 1-1/2" HOSE CLAMP
4. 1-1/2" ID PEX VAPOR EXTRACTION HOSE
5. 1/2" ID PTFE GROUNDWATER EXTRACTION HOSE
6. 1-1/2" HOSE CLAMP
7. 1-1/2" PEX BARB X 1-1/2" M NPT
8. 1-1/2" F NPT X 1-1/2" F CAMLOCK (PART D), ALUM. ALLOY
9. 1-1/2" M CAMLOCK X 1-1/2" M NPT (PART F), ALUM. ALLOY
10. 1-1/2" NPT BALL VALVE, BRASS
11. 1-1/2" NPT CLOSE NIPPLE, GALV.
12. 1-1/2" NPT STREET ELBOW, GALV.
13. 1/2" NPT BALL VALVE, BRASS
14. 1/2" NPT CLOSE NIPPLE, GALV.
15. 1-1/2" M NPT X 1/2" F NPT REDUCER BUSHING, GALV.
16. 1-1/2" F NPT X 1-1/2" F NPT X 1-1/2" F NPT TEE, GALV.
17. 1-1/2" NPT CLOSE NIPPLE, GALV.
18. 1-1/2" F NPT PIPE SADDLE, CARBON STEEL
19. 2" TO 12" Ø PIPE HEADER, CARBON STEEL
20. 1/2" HOSE CLAMP
21. 1/2" M NPT TO X 1/2" HOSE BARB
22. 1/2" SWING CHECK VALVE, BRASS
23. 1/2" NPT CLOSE NIPPLE, GALV.
24. 2" TO 6" Ø STEAM HEADER, CARBON STEEL
25. 1" Ø AIR SUPPLY LINE, CARBON STEEL
26. 1" F NPT WELDOLET, CARBON STEEL
27. 1" NPT BALL VALVE, SS
28. 1" HAMMER LOCK ASSEMBLY, ZINC PLATED DUCTILE IRON
29. 1" COLLAR LOCK BOLT CLAMP, PLATED DUCTILE IRON
30. 1" STEAM HOSE

TEMPERATURE MONITORING POINT

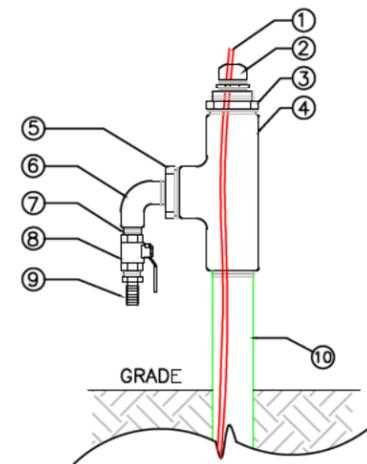

TEMPERATURE COMPONENTS

1. TEMPERATURE SENSOR STRING, 3/8" STRING DIA.
2. 3/8" X 3/4" M NPT CORD GRIP, NYLON
3. 1-1/2" M NPT X 3/4" F NPT BUSHING, GALV.
4. 1-1/2" NPT PIPE TEE, GALV.
5. 1-1/2" M NPT X 3/8" F NPT BUSHING, GALV.
6. 3/8" NPT STREET ELBOW, GALV.
7. 3/8" NPT CLOSE NIPPLE, GALV.
8. 3/8" NPT BALL VALVE, BRASS
9. 3/8" M NPT X 1/4" HOSE BARB, BRASS
10. 1-1/2" M NPT CARBON STEEL RISER STICKUP



McMILLAN-McGEE CORP.
 ELECTROMAGNETIC SYSTEMS AND SERVICES
 FOR THE ENERGY AND ENVIRONMENTAL INDUSTRIES
 4895 - 358 STREET SE
 CALGARY, AB T2B 3M9 CANADA
 WWW.MCMILLAN-MCGEE.COM
 PH: 403.569.5100, FX: 403.272.7201

REV.	DATE (MM/YY)	DESCRIPTION	DRAWN BY	CHKD BY	APPROVED BY
B2	2021/09/28	90% DESIGN	JB	CC	CC
B1	2021/09/27	80% DESIGN	JB	CC	CC
A3	2021/09/27	UPDATE PEX LINE	JB	CC	CC
A2	2021/09/24	UPDATE NUMBERING	JB	CC	CC
A1	2021/09/19	NOT FOR CONSTRUCTION	JB	CC	CC

DATE: _____
 APEGA PERMIT NUMBER: P09178
 SCALE: NOT TO SCALE

TITLE: **ET-DSP™ Well Head Details**
 CLIENT: **AECOM**

PROJECT: **Roxana Public Works Yard
 Roxana, Illinois**

SHEET: **WHD-01**

LEGEND:

- WASTE WATER AND GROUND WATER
- TREATED WATER
- CHILLER LIQUID
- COOLING TOWER WATER
- AIR
- VAPOURS
- NAPL
- SLUDGE

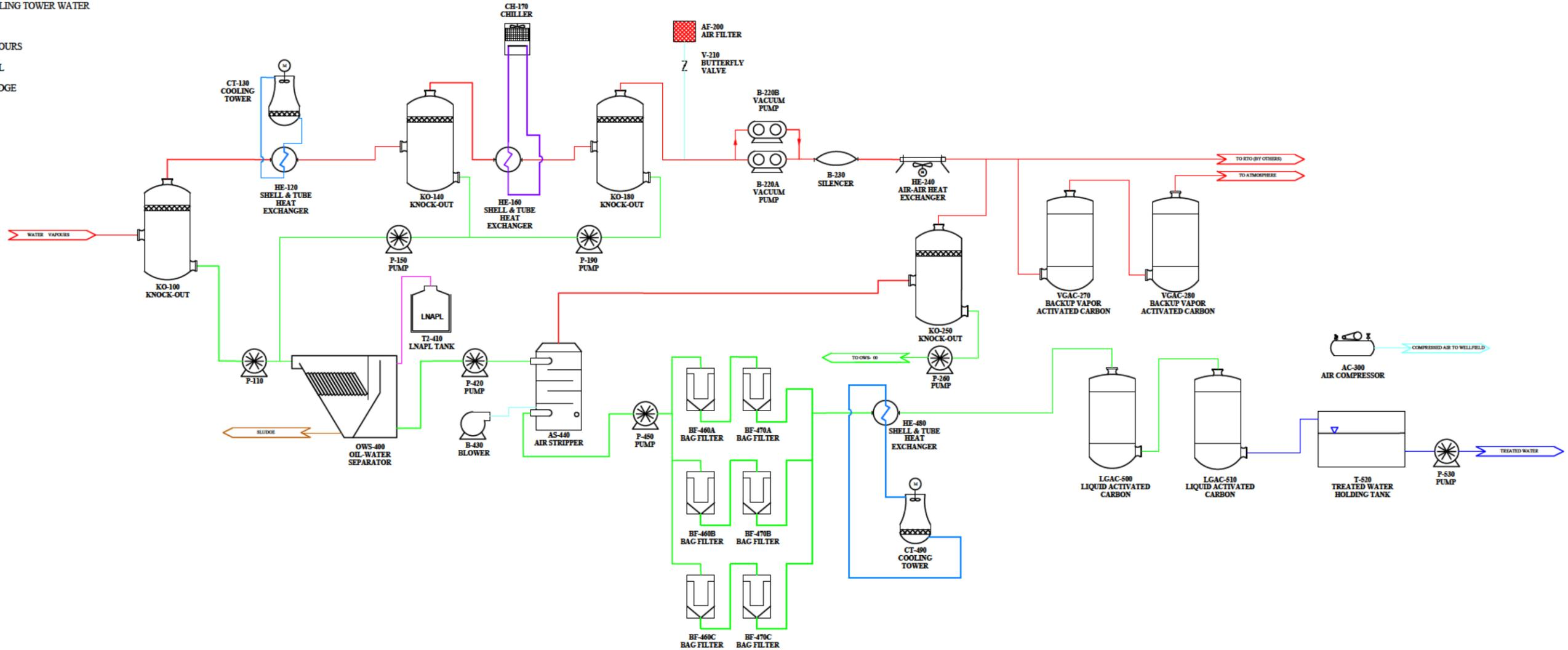

KO-100 KNOCK-OUT 3.5 FT DIA 200 gal BTWN HIGH AND LOW LEVEL	P-110 50 gpm AT 50 FT HEAD	HE-120 SHELL & TUBE HEAT EXCHANGER 2E6 BTU/HR INLET: 113°F -975 FT ² SA 111 gpm CW	CT-130 COOLING TOWER 111 gpm CW INLET: 113°F OUTLET: 77°F	KO-140 KNOCK-OUT 2.5 FT DIA 100 gal BTWN HIGH AND LOW LEVEL	P-150 PUMP 10 gpm AT 50 FT HEAD	HE-160 SHELL & TUBE HEAT EXCHANGER 1.8E5 BTU/HR -822 FT ² SA 19.7 gpm COOLANT	CH-170 CHILLER 1.8E6 BTU/HR COOLANT IS 50% PROPYLENE GLYCOL/50% WATER	KO-180 KNOCK-OUT 2.5 FT DIA 100 gal BTWN HIGH AND LOW LEVEL	P-190 PUMP 5 gpm AT 50 FT HEAD	AF-200 AIR FILTER FOR 4 IN VAPOUR LINE 500 SCFM	V-210 BUTTERFLY VALVE 4 IN	B-220A/B VACUUM PUMP Sutorbilt Legend DSL 6LV 891 SCFM 21.5 LB/H WATER VAPOUR	B-230 SILENCER 891 SCFM 80 dB AT 5 FT HEAD	HE-240 FIN-FAN HEAT EXCHANGER 7.2E5 BTU/HR -1250 FT ² SA	KO-250 KNOCK-OUT 2.5 FT DIA 100 gal BTWN HIGH AND LOW LEVEL	P-260 PUMP 5 gpm AT 50 FT HEAD	VGAC-270 BACKUP VAPOR ACTIVATED CARBON 5.0 FT DIA 2500 LB	VGAC-280 BACKUP VAPOR ACTIVATED CARBON 5.0 FT DIA 2500 LB	
	AC-300 AIR COMPRESSOR 32 SCFM AT 150 psig	OWS-400 OIL-WATER SEPARATOR 20 µm OIL DROPLET SEPARATION AT 50 gpm	T2-410 LNAPL TANK 250 gal	P-420 PUMP 50 gpm AT 100 FT HEAD	B-430 BLOWER 600 SCFM	AS-440 AIR STRIPPER A:W RATIO OF 74.8	P-450 PUMP 50 gpm AT 50 FT HEAD	BF-460A/B BAG FILTER TRADE SIZE 2	BF-470A/B BAG FILTER TRADE SIZE 2	HE-480 SHELL & TUBE HEAT EXCHANGER 2.02E6 BTU/HR -1000 FT ² SA	CT-490 COOLING TOWER 113 gpm CW INLET: 113°F OUTLET: 77°F	LGAC-500 LIQUID ACTIVATED CARBON 3.6 FT DIA 2000 LB	LGAC-510 LIQUID ACTIVATED CARBON 3.6 FT DIA 2000 LB	T-520 TREATED WATER HOLDING TANK 5000 gal	P-530 PUMP 50 gpm AT 50 FT HEAD				

FOR REVIEW AND COMMENT



McMILLAN-McGEE CORP.
ELECTROMAGNETIC SYSTEMS AND SERVICES
FOR THE ENERGY AND ENVIRONMENTAL INDUSTRIES
4895 - 358 STREET SE
CALGARY, AB T2B 3M9 CANADA
WWW.McMILLAN-McGEE.COM
PH: 403.569.5100, FX: 403.272.7201

REV.	DATE	DESCRIPTION	DRAWN BY	CHKD BY	APPROVED BY
B3	2021/08/30	90% DESIGN	JS	JS	DAR
B2	2021/08/27	REVISE EQUIPMENT AND ADD SPEC	JS	JS	DAR
B1	2021/08/27	90% DESIGN	JS	JS	DC
A1	2020/03/08	FOR REVIEW AND COMMENT	TL	TL	DAR
REV.	DATE	DESCRIPTION	DRAWN BY	CHKD BY	APPROVED BY

DATE: _____
SCALE: NOT TO SCALE
APEGA PERMIT NUMBER: P09178

TITLE: **Process Flow Diagram**
CLIENT: **AECOM**

PROJECT: **Roxana Public Works Yard
Roxana, Illinois**

SHEET: **PFD-01**

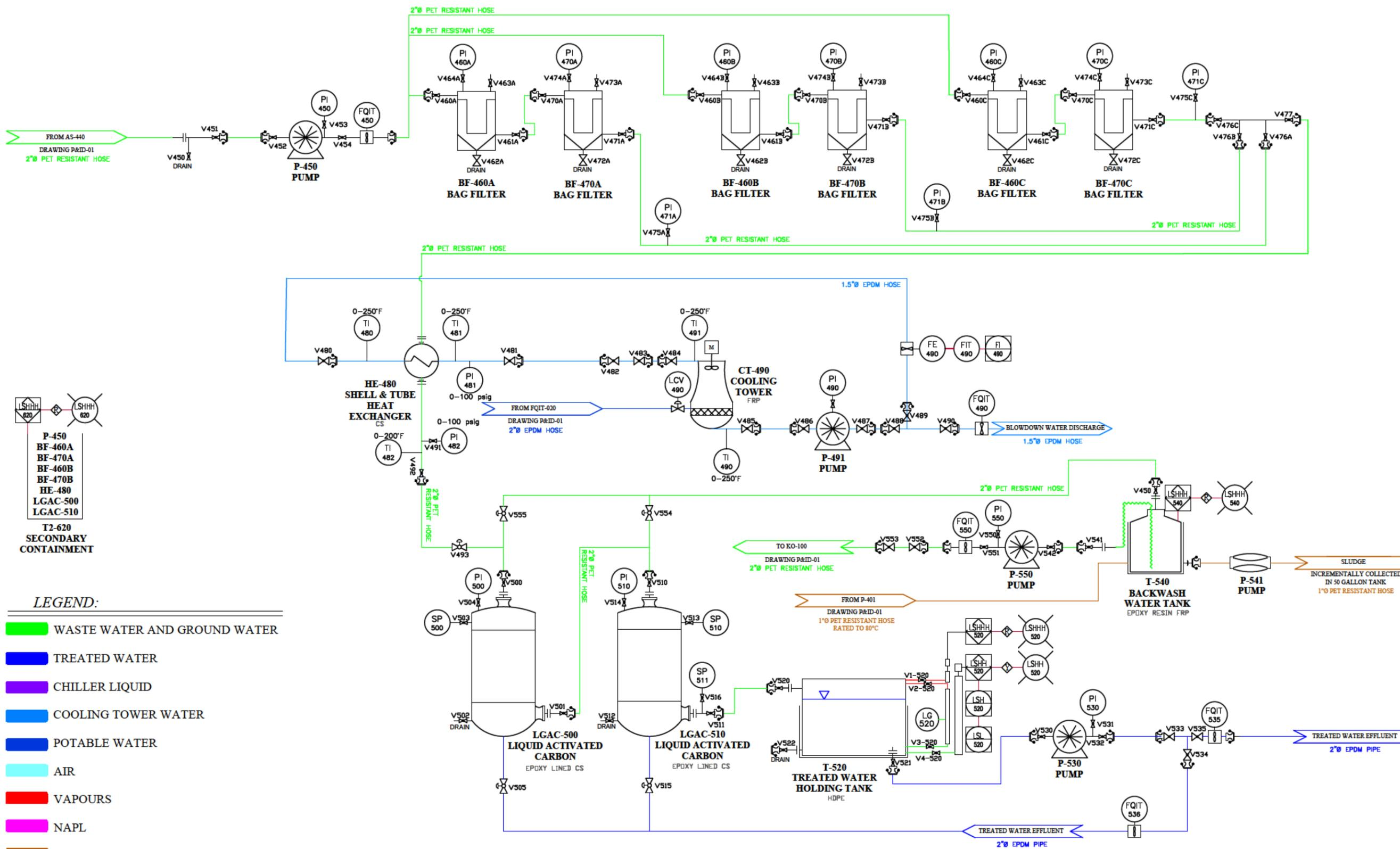

- LSHH 620
- LSHH 620
- P-450
- BF-460A
- BF-470A
- BF-460B
- BF-470B
- HE-480
- LGAC-500
- LGAC-510
- T2-620
- SECONDARY CONTAINMENT

LEGEND:

- WASTE WATER AND GROUND WATER
- TREATED WATER
- CHILLER LIQUID
- COOLING TOWER WATER
- POTABLE WATER
- AIR
- VAPOURS
- NAPL
- SLUDGE

FOR REVIEW AND COMMENT



McMILLAN-McGEE CORP.
 ELECTROMAGNETIC SYSTEMS AND SERVICES
 FOR THE ENERGY AND ENVIRONMENTAL INDUSTRIES
 4895 - 358 STREET SE
 CALGARY, AB T2B 3M9 CANADA
 WWW.McMILLAN-McGEE.COM
 PH: 403.569.5100, FX: 403.272.7201

REV.	DATE	DESCRIPTION	DRAWN BY	ORIG. ENGR.	APPROVED
B1	2021/09/28	80% DESIGN	JS	JS	DAR
A1	2021/09/22	FOR REVIEW AND COMMENT	JS	JS	DAR
APEGA PERMIT NUMBER: P09178 SCALE: NOT TO SCALE					

Process and Instrumentation Diagram
AECOM

Roxana Public Works Yard
 Roxana, Illinois

P&ID-04

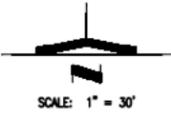

BENCHMARK:
 CHESEBOLD SQUARE ON TOP OF
 SOUTHEAST CORNER OF AERATION BASIN
 STRUCTURE. ELEVATION = 444.97

EXISTING TOPOGRAPHIC LEGEND

- | | |
|---|---|
| <ul style="list-style-type: none"> □ HOUSE — UTILITY POLE — BURIED TELEPHONE CABLE ○ TELEPHONE PEDESTAL (SPURCE BOX) ● IRON PIN (PROPERTY CORNER) — RIGHT OF WAY MARKER — RIGHT OF WAY LINE — PROPERTY LINE — CENTER LINE OF ROADWAY/SURVEY — FENCE LINE — FENCE GATE — CONCRETE SIDEWALK — OPEN DRAINAGE DITCH — DRAINAGE CULVERT — 12" S/S STORM SEWER — STORM SEWER INLETS — BUSH/SHRUB ○ 12" ROAD/STREET SIGN | <ul style="list-style-type: none"> ○ SANITARY SEWER MANHOLE ○ SANITARY SEWER (GRAVITY) — 12" W WATER MAIN — WATER MAIN GATE VALVE & BOX — FLUSHING HYDRANT — TWO WAY FIRE HYDRANT — THREE WAY FIRE HYDRANT — WATER METER — GAS MAIN — GAS MAIN VENT PIPES — GAS METER — RAILROAD CROSSING SIGN — RAILROAD ELECTRICAL CONTROL BOX — CULTIVATION LINE — UNPAVED ROADWAY — PAVED ROADWAY — CONCRETE DRIVE/PAD — SPOT ELEVATION |
|---|---|

KEY TO UNITS

MARK	DESCRIPTION
(A)	PROPOSED TERMINAL PUMP STATION WITH VALVE VAULT
(B)	REMOVE AND REPLACE INFLUENT COMMINUTOR
(C)	EXISTING COMMINUTOR (INFLUENT FROM RAIFORT INDUSTRIAL PARK)
(D)	EXISTING AERATION TANKS, PROVIDE PROPOSED DIFFUSED AERATION EQUIPMENT
(E)	PROVIDE PROPOSED FLOW SPLITTER
(F)	PROVIDE PROPOSED CLARIFIER
(G)	PROVIDE PROPOSED EFFLUENT PARSHALL FLUME WITH AUTOMATIC COMPOSITE SAMPLER
(H)	PROVIDE PROPOSED OUTFALL MANHOLE
(I)	PROVIDE PROPOSED CONTROL BUILDING (SLUDGE PUMPS, BLOWERS, SLUDGE DEWATERING)
(J)	CONVERT EXISTING SETTLING BASINS TO SLUDGE STORAGE/THICKENING
(K)	PROVIDE PROPOSED AEROBIC DIGESTERS
(L)	PROVIDE 5' DIA. PRECAST CONCRETE MANHOLE

PIPING SCHEDULE

MARK	DESCRIPTION
(1)	PROPOSED 12" VILLAGE INFLUENT GRAVITY SEWER
(2)	PROPOSED 8" VILLAGE INFLUENT FORCE MAIN
(3)	PROPOSED 18" AERATION TANK EFFLUENT TO CLARIFIERS
(4)	PROPOSED 16" CLARIFIER INFLUENT
(5)	PROPOSED 16" CLARIFIER EFFLUENT
(6)	PROPOSED 18" PLANT EFFLUENT
(7)	PROPOSED 8" CLARIFIER WASTE SLUDGE/SCUM/DRAIN TO SLUDGE PUMPS
(8)	PROPOSED 10" CLARIFIER WASTE SLUDGE/SCUM/DRAIN TO SLUDGE PUMPS
(9)	PROPOSED 8" RAS TO AERATION TANKS
(10)	PROPOSED 8" WAS TO AEROBIC DIGESTERS
(11)	PROPOSED 8" DIA. DIGESTED SLUDGE TO SLUDGE PUMPS
(12)	PROPOSED 4" DIA. SLUDGE TO THICKENERS
(13)	PROPOSED 6" THICKENED SLUDGE TO BELT FILTER PRESS FEED PUMP
(14)	PROPOSED 6" SLUDGE DEWATERING FILTRATE RETURN TO VILLAGE INFLUENT PUMP STATION
(15)	PROPOSED 8" DIGESTER SUPERNATANT RETURN TO VILLAGE INFLUENT PUMP STATION
(16)	EXISTING 10" EFFLUENT SEWER, CONVERT FOR USE TO RETURN FILTRATE AND SUPERNATANT TO VILLAGE INFLUENT PUMP STATION
(17)	PROPOSED 10" FILTRATE AND SUPERNATANT RETURN
(18)	PROPOSED 12" AIR LINE
(19)	PROPOSED 8" AIR LINE TO AERATION TANKS
(20)	PROPOSED 8" AIR LINE TO AEROBIC DIGESTERS

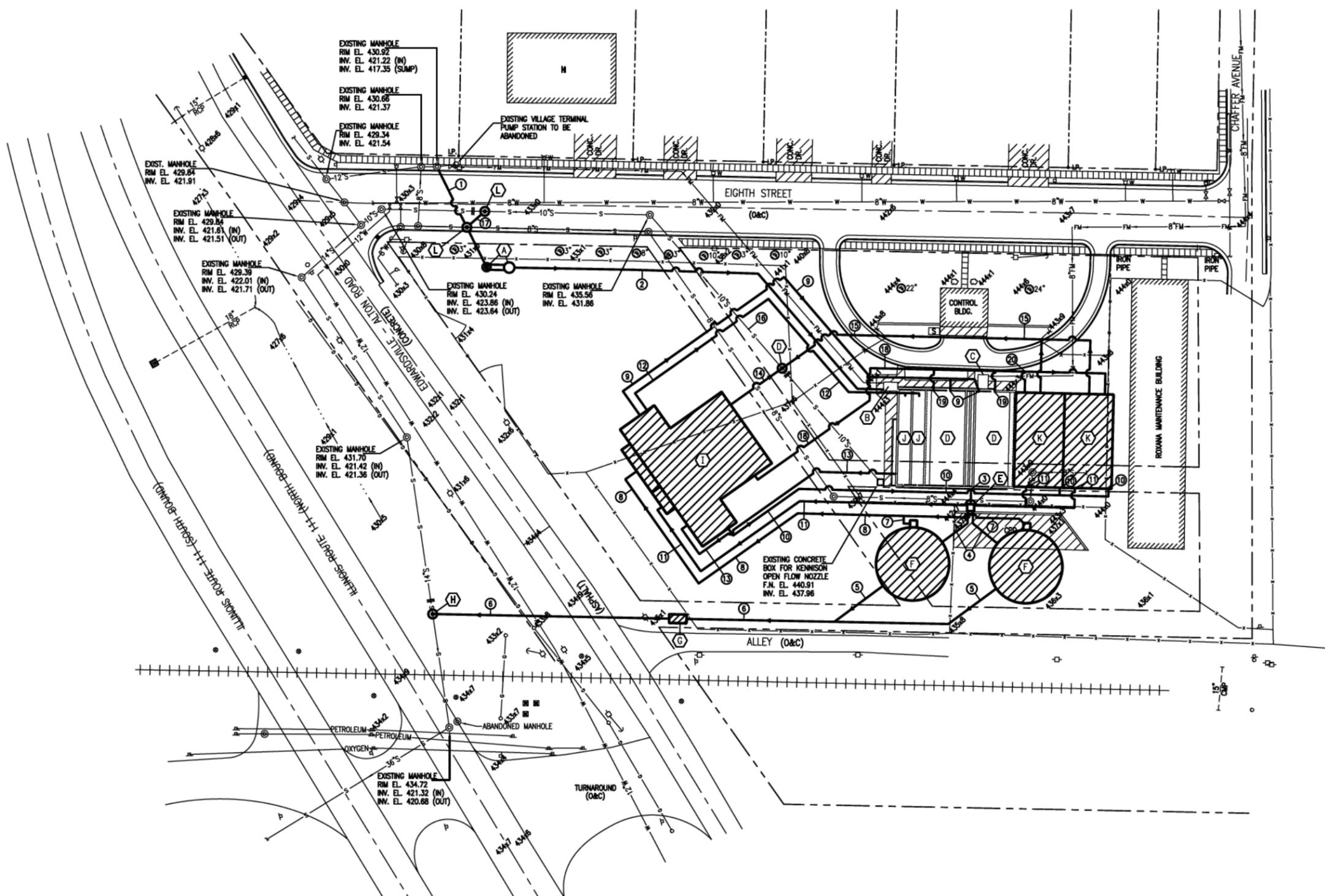

EXIST. IEPA OPERATING PERMIT 1999-AO-2879

WASTEWATER TREATMENT PLANT CAPACITY INCREASE VILLAGE OF ROXANA, ILLINOIS

C U R R Y		Revisions Survey Design MDC Drawn A.L.K. B.E.J. Checked	SHEET 1 OF
 ENGINEERS, INC. NASHVILLE, ILLINOIS			
& ASSOCIATES			

EXISTING SITE PIPING SCHEDULE

MARK	SIZE/MATERIAL	DESCRIPTION	FLOW
1	12" SDR 26 PVC WITH #12 TRACER WIRE	INFLUENT FORCE MAIN	FORCE MAIN
2	12" CL 53 D.I.	METERED INFLUENT FLOW	FORCE MAIN
3	16" CL 53 D.I.	FINE SCREEN EFFLUENT	GRAVITY
4	16" SDR 26 PVC	RAW MIXED LIQUOR	GRAVITY
5	16" SDR 26 PVC	TEE WITH CAP FOR FUTURE	GRAVITY
6	16" SDR 26 PVC	BIOLAC BASIN INFLUENT	GRAVITY
7	8" SDR 26 PVC	BIOLAC BASIN DRAIN	GRAVITY
8	16" SDR 26 PVC	BIOLAC BASIN EFFLUENT	GRAVITY
9	16" SDR 26 PVC	BIOLAC BASIN COMBINED EFFLUENT	GRAVITY
10	16" SDR 26 PVC	CLARIFIER INFLUENT	GRAVITY
11	16" SDR 26 PVC	CLARIFIER EFFLUENT	GRAVITY
12	16" SDR 26 PVC	CLARIFIER EFFLUENT	GRAVITY
13	16" SDR 26 PVC	U.V. INFLUENT	GRAVITY
14	16" SDR 26 PVC	U.V. EFFLUENT	GRAVITY
15	8" CL 53 D.I.P.	TREATED EFFLUENT FORCE MAIN	FORCE MAIN
16	12" SDR 21 PVC WITH #12 TRACER WIRE	TREATED EFFLUENT FORCE MAIN	FORCE MAIN
17	8" SDR 26 PVC WITH #12 TRACER WIRE	RAS/WAS FORCE MAIN	FORCE MAIN
18	8" SDR 26 PVC WITH #12 TRACER WIRE	RAS FORCE MAIN	FORCE MAIN
19	8" CL 53 D.I.P.	WAS FORCE MAIN	FORCE MAIN
20	8" CL 53 D.I.P.	WAS FORCE MAIN	FORCE MAIN
21	8" CL 53 D.I.P.	THICKENED EFFLUENT SLUDGE	GRAVITY
22	8" CL 53 D.I.P.	THICKENED EFFLUENT SLUDGE	GRAVITY
23	6" CL 53 D.I.P.	THICKENED EFFLUENT SLUDGE	FORCE MAIN
24	6" SDR 26 PVC WITH #12 TRACER WIRE	THICKENED EFFLUENT SLUDGE	FORCE MAIN
25	6" SDR 26 PVC	THICKENED EFFLUENT SLUDGE - POLYMER FEED INFLUENT	FORCE MAIN
26	6" SDR 26 PVC	POLYMER TREATED SLUDGE	FORCE MAIN
27	6" CL 53 D.I.P.	DRYING BED INFLUENT	FORCE MAIN
28	6" PERFORATED HDPE PIPE	FILTERED DRYING BED EFFLUENT	GRAVITY
29	6" CL 53 D.I.P.	FILTERED DRYING BED EFFLUENT	GRAVITY
30	6" SDR 26 PVC	FILTERED DRYING BED EFFLUENT	GRAVITY
31	4" SDR 26 PVC	SLUDGE STORAGE FLOOR DRAINS	GRAVITY
32	8" SDR 26 PVC	SLUDGE STORAGE LOT DRAINS	GRAVITY
33	4" SDR 26 PVC	GARAGE/LAB SEWER	GRAVITY
34	12" SDR 26 PVC	PUMP STATION NO. 4 INFLUENT	GRAVITY
35	4" SDR 26 PVC	BLOWER BUILDING FLOOR DRAINS	GRAVITY
36	16" SDR 26 PVC	TEE WITH CAP FOR FUTURE	GRAVITY
37	6" CL 53 D.I.P.	CLARIFIER SLUDGE EFFLUENT	GRAVITY
38	8" SDR 26 PVC	BIOLAC BASIN DRAINS	GRAVITY
39	6" CL 53 D.I.P.	DIGESTER DECANT	GRAVITY
40	6" CL 53 D.I.P.	DIGESTER DECANT	GRAVITY
41	6" SDR 26 PVC	DIGESTER DECANT	GRAVITY
42	6" CL 53 D.I.P.	PROCESS WASTE	FORCE MAIN
43	6" SDR 26 PVC WITH #12 TRACER WIRE	PROCESS WASTE	FORCE MAIN
44	4" SDR 26 PVC WITH #12 TRACER WIRE	DRYING BED SATURATION LINE	FORCE MAIN
45	12" SDR 21 PVC WITH #12 TRACER WIRE	POTABLE WATER LINE	PRESSURE
46	6" SDR 21 PVC WITH #12 TRACER WIRE	POTABLE WATER LINE	PRESSURE
47	3" SDR 21 PVC WITH #12 TRACER WIRE	SERVICE CONNECTION - POTABLE WATER WITH CORP. STOP	PRESSURE
48	2" SCH. 40 PVC WITH #12 TRACER WIRE	WATER SERVICE/INFLUENT PROCESS SPRAY WATER PUMP STATION	PRESSURE
49	3" SDR 21 PVC WITH #12 TRACER WIRE	PROCESS SPRAY WATER	PRESSURE
50	(OPEN)		
51	6" CL 53 D.I.P.	SCUM DRAIN LINE	GRAVITY
52	2" SCH. 40 PVC	SCUM LINE	FORCE MAIN
53	12" SCH. 40 STEEL (WELDED)	PROCESS AIR FROM BLOWERS	LOW PRESSURE AIR
54	10" SCH. 40 STEEL (WELDED)	PROCESS AIR FROM BLOWERS	LOW PRESSURE AIR
55	8" SCH. 40 STEEL (WELDED)	PROCESS AIR FROM BLOWERS	LOW PRESSURE AIR
56	6" SCH. 40 STEEL (WELDED)	PROCESS AIR FROM BLOWERS	LOW PRESSURE AIR
57	4" SCH. 40 STEEL (WELDED)	PROCESS AIR FROM BLOWERS	LOW PRESSURE AIR
58	6" CL 53 D.I.P.	DRYING BED FILL LINE DRAIN (FREEZE PREVENTION)	GRAVITY
59	4" SDR 26 PVC	WATER PLANT PROCESS WASTE	FORCE MAIN

NOTE: ALL DUCTILE IRON PIPING AND FITTINGS SHALL HAVE PROTECTO 401 CERAMIC EPOXY LINING.

LEGEND

- FLOW ARROWS
- ⊘ GATE VALVE
- ⊘ P.V. PLUG VALVE
- ⊘ INCREASER/REDUCER
- ⊘ MANHOLE
- ⊘ INVERT ELEVATION
- ⊘ TWO-WAY FLUSH HYDRANT WITH AUXILIARY GATE VALVE AND C.I. BOX
- ⊘ THREE-WAY FIRE HYDRANT WITH AUXILIARY GATE VALVE AND C.I. BOX
- ⊘ CATCH BASIN
- ⊘ METER
- ⊘ CONTROL PANEL
- ⊘ POTABLE WATER LINE
- ⊘ ELECTRICAL JUNCTION BOX
- ⊘ COMPOSITE SAMPLER
- ⊘ EXISTING SOIL BORING, SEE SPECS.
- ⊘ FENCE
- ⊘ ELECTRICAL
- ⊘ RESIDUE BASINS & PIPING
- ⊘ NEW ELECTRICAL/COMMUNICATION LINES
- ⊘ NEW CHEM. AND WATER LINE

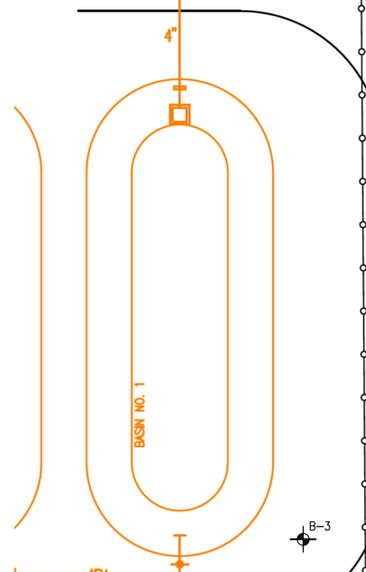

PROPOSED SITE PIPING SCHEDULE
(SEE SHEET 10A & 10B FOR ADDITIONAL PIPING)
(SEE SHEET 10A & 10B FOR BASE BID VS ALT. BID #1)

MARK	SIZE/MATERIAL	DESCRIPTION	FLOW
60	16" SDR 26 PVC	CONTACT BASIN INFLUENT/EFFLUENT	GRAVITY
61	4" CASING, 2 - 3/4" PVC TUBE	PROPOSED LIQUID LIME FEED	
62	3" SDR 21 PVC	PROPOSED PROCESS WATER	
63	6" CASING, 2 - 3/4" PVC TUBE	PROPOSED FERRIC SULFATE FEED	
64	6" CASING, 2 - 1/2" TUBE	PROPOSED BLEACH FEED	
65	4" CASING, 2 - 1/2" TUBE	PROPOSED SODIUM BISULFITE FEED	
66	4" CONDUIT	NEW ELECTRICAL SERVICE	
67	2" SDR 21 PVC	POTABLE WATER SERVICE	
68	6" CASING, 2 - 1/2" TUBE	PROPOSED POLYMER	

BY CONTRACTOR
3 WAY FIRE HYDRANT WITH
AUXILIARY GATE VALVE AND
PLUG VALVE (BASIN FILL
HYDRANT).

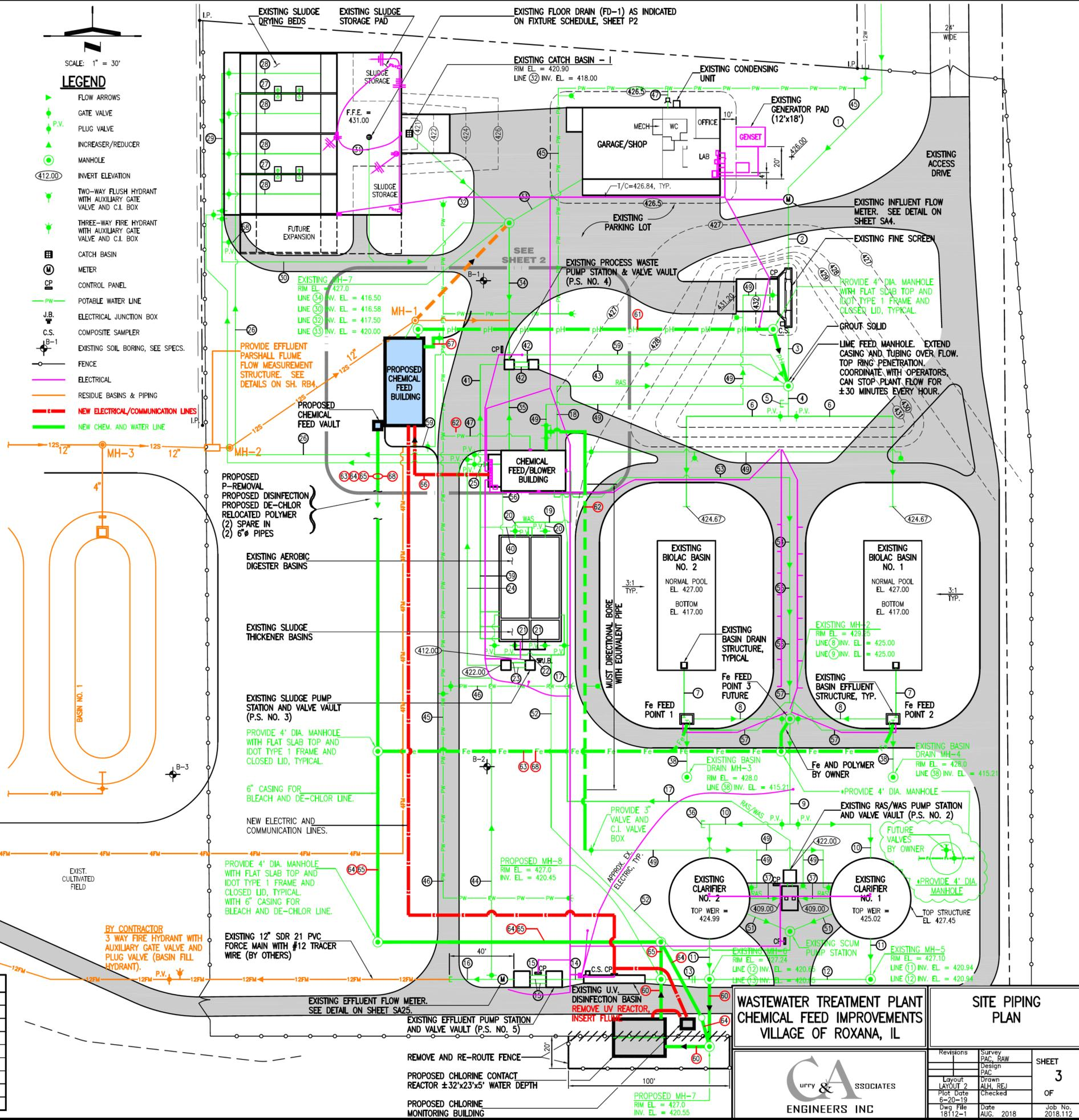

WASTEWATER TREATMENT PLANT
CHEMICAL FEED IMPROVEMENTS
VILLAGE OF ROXANA, IL

CA ENGINEERS INC

Revisions	Survey	PAC, RAW	SHEET
	Design	PAC	
	Layout	ALH, REJ	OF
	Plot	Checked	
	Date	6-20-19	
	Drawn	18112-1	
	Date	AUG. 2018	
	Job No.	2018.112	