

W O R K P L A N

DISSOLVED PHASE  
GROUNDWATER  
INVESTIGATION

*AND*

*P-60 FREE PHASE PRODUCT  
DELINEATION*

ROXANA, ILLINOIS

*Prepared for*

Shell Oil Products US  
Environmental Services  
17 Junction Drive; PMB #399  
Glen Carbon, Illinois 62034

September 5, 2008

*Revised January 21, 2009*



URS Corporation  
1001 Highland Plaza Drive West, Suite 300  
St. Louis, MO 63110  
(314) 429-0100  
**Project No. 21561979**

# TABLE OF CONTENTS

---

SECTION 1	INTRODUCTION, BACKGROUND AND OBJECTIVES .....	1-1
SECTION 2	SUBSURFACE CONDITIONS.....	2-1
SECTION 3	GROUNDWATER QUALITY SUMMARY .....	3-1
3.1	Dissolved Benzene Results .....	3-1
3.2	Separate Phase Hydrocarbon Results .....	3-1
3.3	Dissolved Phase Mixed Hydrocarbon Results .....	<del>3-2</del> 3-3
3.4	Summary.....	<del>3-2</del> 3-3
SECTION 4	DATA COLLECTION ACTIVITIES.....	4-1
4.1	Borehole Clearance .....	4-1
4.2	Groundwater Profiling.....	<del>4-1</del> 4-2
4.3	<i>CPT/ROST and Direct Push Soil Sampling</i> .....	4-3
4.4 <del>4.3</del>	Monitoring Well Installation and Development .....	<del>4-2</del> 4-5
4.5	<i>Piezometer Installation</i> .....	4-6
4.6 <del>4.4</del>	Monitoring Well/ <i>Piezometer</i> Gauging and Sampling .....	<del>4-3</del> 4-7
4.7 <del>4.5</del>	Vapor Monitoring Point Installation .....	<del>4-4</del> 4-9
4.8 <del>4.6</del>	Vapor Monitoring Point Sampling .....	<del>4-5</del> 4-9
4.7 <del>4.7</del>	<del>Direct Push Soil Sampling</del> .....	<del>4-6</del>
4.9 <del>4.8</del>	Surveying .....	<del>4-6</del> 4-11
SECTION 5	ANALYTICAL SAMPLE HANDLING AND QA/QC.....	5-1
SECTION 6	PERSONAL PROTECTIVE EQUIPMENT, DECONTAMINATION PROCEDURES AND INVESTIGATION-DERIVED WASTE HANDLING.....	6-1
SECTION 7	DATA MANAGEMENT, ANALYSIS AND REPORTING .....	7-1
SECTION 8	SCHEDULE.....	8-1

# TABLE OF CONTENTS

---

## List of Tables

Table 1	ConocoPhillips Quarterly Gauging Data – West Fenceline Wells (1Q07-2Q08)
Table 2	2006 Well and Piezometer Gauging Data – 2006 - 2008
Table 3	Summary of Groundwater Analytical Detections and Screening
<del>Table 4</del>	<del>Investigation Location Activity Summary Table</del>
<del>Table 4</del>	<del>Target Reporting List and Screening Levels for Soil, Groundwater and Soil Gas</del>
Table 5	Target Reporting List and Screening Levels - Volatile Organics for Soil and Groundwater
Table 6	Target Reporting List and Screening Levels – Semivolatile Organics for Groundwater
Table 7	Target Reporting List and Screening Levels –Volatile Organics for Soil Vapor

## List of Figures

Figure 1	Site Location Map
<del>Figure 2</del>	<del>West Fenceline Product Occurrence and Thickness</del>
Figure 2	Locations of Groundwater Monitoring Wells at the Wood River Refinery
Figure 3	Locations of Monitoring Points in the Village of Roxana
Figure 4	ROST Response (2006 Investigation Activities)
<del>Figure 4</del>	<del>Proposed Investigation Locations</del>
Figure 5	Product Gauging Results in the Vicinity of Well P-60
Figure 6	Groundwater Analytical BTEX & MTBE Results Map
Figure 7	Proposed Investigation Locations

## List of Attachments

<del>Attachment A</del>	<del>HydraSleeve® Field Manual</del>
Attachment A	CPT Logs, ROST Fluorescence Plots, Soil Boring Logs, and Replacement Well Construction Diagram from 2006 P-60 Investigation
Attachment B	Analytical Data Report for August 2008 Well Sampling
Attachment C	Standard Operating Procedures
Attachment D	HydraSleeve® Field Manual

Shell Oil Products U.S. (SOPUS) is planning to conduct investigative activities in the Village of Roxana in the area generally bounded by Illinois Route 111 and the west property boundary (aka west fenceline) of the WRB Refining LLC Wood River Refinery (WRR) (**Figure 1**). The area is being investigated to:

- 1) Further assess a 1986 benzene release and other *dissolved* hydrocarbon impacts in the area west of the WRR west fenceline; *and*
- 2) *Further delineate the extent of product historically observed in well P-60.*

URS Corporation (URS), on behalf of SOPUS, performed a subsurface investigation in 2006 to help gather information on the extent of benzene impact. The investigation provided initial information on the distribution of benzene in groundwater in the area, using primarily screening technologies (e.g., cone penetration testing (CPT), membrane interface probe (MIP) and groundwater profiling). The report of this work was submitted to the Illinois Environmental Protection Agency (IEPA) on September 28, 2007. Additional work was conducted in the Spring and Summer of 2008 to further delineate the extent of impact. *This work was performed in accordance with a Work Plan which was provided to IEPA on February 15, 2008.* This investigation revealed evidence of hydrocarbon impact, in the form of mixed hydrocarbons, in the area north of the benzene impacts. The report for this work was *initially* submitted to IEPA on August 19, 2008, *and the revised report is being submitted concurrent with this work plan.*

*Product (separate phase hydrocarbon) thicknesses in well P-60, located along the WRR west fenceline, have historically been much greater than in nearby wells (e.g., 6-8 feet or more in P-60 as compared to less than approximately 1 to 2 feet in other locations). It had been suspected that the well was compromised, allowing product possibly in the shallow subsurface to enter the well. A subsurface investigation was performed in the vicinity of well P-60 in 2006 to assess the condition of the well and begin to delineate the extent of product historically observed. The investigation used Cone Penetration Testing (CPT), Rapid Optical Screening Tool (ROST), piezometer installation, and the replacement of well P-60 to gather initial information.*

The IEPA issued SOPUS a Violation Notice dated May 2, 2008 (L-2008-01134) relative to groundwater conditions as identified in the 2007 report. In response, SOPUS submitted a proposed Compliance Commitment Agreement (CCA) to IEPA on July 22, 2008. While the CCA was rejected by the IEPA in correspondence dated August 4, 2008, SOPUS has been

instructed verbally by ~~that agency~~ IEPA to conduct the subject work. *The CCA included preparation of an investigation work plan, which was submitted to IEPA on September 5, 2008. IEPA provided comments on the plan in a letter dated November 25, 2008.*

The primary objectives of this investigation are to:

- Refine our understanding of the extent of benzene impact;
- Assess the nature and extent of *dissolved* hydrocarbons identified along the west fenceline of the WRR; *and*
- *Gather data to assist in the delineation of the extent of product historically observed in the area of well P-60.*

*Based on IEPA's November 25, 2008 letter, the Work Plan has been revised. The "Response to Comments" document summarizes the revisions to the plan. Text additions based on those comments are shown in italic font. Text removed from the plan based on those comments is shown in strike-through format.*

The investigative site and surrounding area, located approximately 0.7 miles east of the Mississippi River, are located on a broad floodplain known as the American Bottoms. The surface topography across the investigation area generally slopes downward to the west-southwest, with a total drop in elevation of approximately 15 feet across the area. The floodplain deposits consist of recent alluvial (i.e., river) deposits overlying Pleistocene (i.e., Ice Age) glacial outwash. The recent alluvial deposits consist of a complex, heterogeneous sequence of sands, silts, and clays. The underlying glacial outwash deposits consist of more uniform sands and gravels that extend to bedrock. The depth to bedrock in the area typically exceeds 100 feet.

The glacial outwash deposits (i.e., sands) underlying the area are the primary source for large volume water production in the area (e.g., industrial and municipal supply). Prior to development in the area, the natural movement of groundwater through the valley material was toward the west (toward the Mississippi River). Since development in the area, groundwater pumping has significantly altered this pattern. Regional groundwater flow in the area is directed toward nearby pumping centers, locally the WRR to the east and the BP former Wood River refinery to the west.

The sand unit is water-saturated below a depth of approximately 35 to 50 feet bgs (approximately elevation 397 to 395). Groundwater flow in the sand in the investigation area is generally toward the northeast, toward WRR pumping centers.

Groundwater data from the previous SOPUS investigations in the Village and data from along the west fenceline of the WRR have been reviewed in order to develop this work plan. **Figure 2** shows the locations of monitoring wells on WRR property. **Figure 3** shows the locations of monitoring points within the Village of Roxana. Information from this review is summarized below.

### 3.1 DISSOLVED BENZENE RESULTS

Cumulative analytical information from the previous investigations indicates the highest benzene concentrations generally in a band on the order of 200 feet wide, extending between the 1986 benzene release location and the refinery. The core area of impact widens closer to the refinery, consistent with groundwater flow toward pumping centers on the WRR North and Main properties. Benzene concentrations in the core area have been identified in the hundreds to thousands of part per million (ppm). Wells on the north and south sides of this band exhibit less than 5 parts per billion (ppb) benzene concentrations<sup>1</sup>.

### 3.2 SEPARATE PHASE HYDROCARBON RESULTS

Quarterly gauging data for the monitoring wells along the west fenceline of the North Property, from First Quarter 2007 (1Q07) through Second Quarter 2008 (2Q08), were reviewed. The quarterly groundwater gauging data for these wells can be found in **Table 1**. ~~**Figure 2** illustrates the occurrence and thickness of separate phase hydrocarbon observed in these wells.~~

Well P-60 has exhibited light non-aqueous phase liquid (LNAPL) over the years and previous efforts have been conducted to recover product, as well as better understand this situation. It had been thought that the well integrity was compromised, allowing product at shallow depths in the subsurface to enter the well. In the Spring of 2006, free-phase product investigation activities were performed in the vicinity of monitoring well P-60 located in the WRR near the west fenceline. Cone Penetrometer Testing (CPT) and Rapid Optical Screening Tool (ROST) probes were performed to gather a soil stratigraphic profile and information on the extent of hydrocarbons in the soil. **Figure 4** illustrates the ROST response observed at these 2006 investigation locations. The ROST identified impacts were primarily diesel range hydrocarbons with some gasoline, jet fuel and heavy-end hydrocarbons also observed. The percent

---

<sup>1</sup> Refer to **Figure 11** of the *Route 111/Rand Avenue Vicinity Subsurface Investigation Report*, dated August 2008, revised January 2009 (prepared by URS for SOPUS) for more information.

fluorescence indicated by the ROST unit ranged from non-detect to about 190. Possible zones of LNAPL or residual hydrocarbon are indicated by ROST responses greater than 100% fluorescence. Soil borings were advanced for visual observation at locations where the CPT/ROST logs indicated potential hydrocarbon presence. Temporary piezometers were installed for subsequent gauging at locations where visual observation of soil cores noted potential separate phase hydrocarbon impact. A shallow temporary piezometer was also installed just east of well P-60 to a depth of approximately 25 feet below ground surface (bgs), which was based on the presence of a silty clay layer observed in some of the CPT borings. Since it was suspected that well P-60 was compromised, it was plugged and abandoned, and a new replacement monitoring well was installed (P0-60(II)). Free-phase product was still present after the installation of the new P-60 well; therefore it is believed that the LNAPL is present on the water table.

CPT logs, ROST fluorescence plots, soil boring logs, and the replacement monitoring well construction diagram are presented in **Attachment A**.

The periodic gauging data for the P-60 replacement well and the surrounding temporary piezometers can be found in **Table 2**. **Figure 5** shows the locations of the temporary piezometers installed relative to well P-60 and shows product gauging information.

~~After installation of the replacement well, LNAPL continued to be observed. A Xitech Instruments Inc. (Xitech) ADJ 200 Smart Skimmer pump system was installed in well P-60 in May 2008 to conduct a field evaluation of the technology. The system is presently operating on a schedule where it cycles on six times per day, and pumps for 10 minutes per cycle. This run time is yielding approximately 1 gallon of product per day. The system is monitored on a regular basis and is being optimized. The intent of this evaluation is to gather data that may be used in designing any potential product recovery systems installed at the site in the future. The current system is not necessarily intended to be a stand-alone remediation system.~~

Product depth and thickness are being monitored and recorded on a weekly basis. Based on these measurements along with consultation with Xitech, the depth to pump, cycles per day, and run-time per cycle are periodically being adjusted to determine the optimal operation for this unit.

The initial number of cycles per day and run-time per cycle were based on recommendations from Xitech based on the initial product thickness, subsurface lithology, and apparent product

recovery rates.

### 3.3 DISSOLVED PHASE MIXED HYDROCARBON RESULTS

*In 2006, and again in Spring 2008, wells in the vicinity of the southern portion of the North property west fenceline were sampled. In Spring 2008, the temporary wells in the Village of Roxana were sampled. On August 8, 2008, three additional wells along the northern portion of the North Property west fenceline were sampled and analyzed for VOCs. The analytical report for this data is included in Attachment B. The analytical detections from this sampling are given in Table 3 and the analytical detections of benzene, toluene, ethylbenzene and xylenes (BTEX) and MTBE are shown in Figure 6. This figure depicts BTEX and MTBE results for all of the above sampling.*

### 3.4 SUMMARY

The cumulative data indicate groundwater impact by petroleum constituents along portions of the west fenceline *and to some degree in the Village of Roxana*. Separate phase hydrocarbons are present in wells in the southern portion of the fenceline (e.g., P-58, P-66) and near the middle of the west fenceline (e.g., P-59, T-12, P-60). Dissolved phase concentrations quickly decrease to ppb levels north of well P-60, and are non detect in wells north of P-55 (i.e., T-1, T-13). ~~For this reason, First Street marks the northern boundary of the investigation area.~~ *For this reason, the data collection activities proposed in this work plan do not extend north of First Street.* Benzene concentrations are relatively higher along the southern roughly 1/3 of the fenceline (e.g., P-93A, P-57). *If the results of these proposed investigation activities indicate that further delineation is required in any direction, then additional investigation activities will be conducted.*

Data collection activities will consist of: groundwater profiling; *soil sampling*; monitoring well installation, development, gauging and sampling; *piezometer installation and gauging*; vapor monitoring point installation and sampling; and surveying. ~~Figure 4~~ **Figure 7** shows the planned sampling locations and **Table 4** summarizes the sampling method, sample type and analysis proposed at each location.

Health and Safety during these investigation activities will be governed by the *Route 111/Rand Avenue Vicinity Investigation Health and Safety Plan (HASP)* dated May 2008 (and updates) as prepared by URS. This HASP is flexible in the types of activities identified in order to account for possible adjustments going forward.

The investigation locations are shown in ~~Figure 4~~ **Figure 7** and are subject to accessibility and utility locations. The proposed locations represent a starting point or baseline. Locations may be added based on field observations or results obtained during the work. Investigation locations will be marked in the field (e.g. spray paint, stakes). The proposed locations will be reviewed with Village of Roxana representatives and Illinois' Joint Utility Locating Information for Excavators (JULIE) (SOP 5 – Utility Clearance). Most of the locations are on Village property (e.g., alley rights of way). Some of the soil borings are located on Illinois Department of Transportation (IDOT) property (i.e., Route 111 right of way) or Village of Hartford property (i.e., Rand Avenue right of way).

The following paragraphs describe the investigation activities. ~~References are made to URS' Standard Operating Procedures (SOPs) for certain investigative procedures. The SOPs are incorporated by reference, but are not included in this work plan.~~ *The URS Standard Operating Procedures (SOPs) referenced throughout this and the following sections can be found in Attachment C.*

#### 4.1 BOREHOLE CLEARANCE

An air-vac system or hand augering will be used to perform air-knife holes to depths of 5 to 10 feet below ground surface (bgs) in order to verify that no utility lines or other obstructions are present at each proposed subsurface location. The specific target depths of the air-knife holes will be determined based upon a review of the subsurface utilities in the area. The air-knife work will be conducted by a vacuum excavation firm contracted and supervised by URS (SOP 5 – Utility Clearance Procedures).

## 4.2 GROUNDWATER PROFILING

Groundwater profiling will initially be conducted at the 21 locations shown on the primary-north-south transects transect and the location on the west side of Route 111, north of the 1986 benzene release point. Profile locations are designated GWP-1 through GWP-21 and are shown in **Figure 4 Figure 7**. The intent of the profiling is to delineate the groundwater plume.

Profiling activities will be performed using a 4-foot long, mill-slotted sampler advanced by the hydraulic push system of a Geoprobe®. Samples will be collected from the top of the groundwater table surface (approximate) and at a depth of approximately 8 foot below the first sample. The sampler will be positioned, ~~the water level will be gauged,~~ and samples will be collected (SOP 42 – Groundwater Profiling). *Based on field observations (e.g., odor or PID headspace screening), additional samples may be collected with depth.* Prior to sampling, the groundwater will be purged and monitored for pH, temperature, conductivity, turbidity, dissolved oxygen (DO), and oxygen-reduction potential (ORP). Parameter readings will be collected after each flow-through cell volume and purging will continue until water-quality parameters have stabilized over 3 flow-through cell volumes or for 1 hour, whichever occurs first (SOP 33-Water Quality Monitoring). Once stabilization is achieved, the groundwater flow will be diverted from the flow-through cell and the groundwater will be sampled.

*The following analytical approach is proposed to increase the efficiency and pace of this task. Profiling will begin with the locations on the Primary Profiling Transect (GWP-1 through GWP-10). The samples collected from these locations will be analyzed by the laboratory for semi-volatile organic compounds (SVOCs) on an expedited basis (e.g., 24 hour). The samples will also be analyzed for volatile organic compounds (VOCs) via local laboratory (refer to **Section 7** for additional information on the planned analyses). The SVOC analytical results from these samples will be compared with the Class I Groundwater Quality Standards (GQSs) (**Table 5**) to determine if SVOC analysis will be performed at profiling locations along the secondary and/or tertiary profiling transects.*

*Groundwater samples will be collected for analysis of VOCs and SVOCs from the secondary (GWP-11 through GWP-15) and tertiary (GWP-16 through GWP-20) transect locations shown in **Figure 7**. The samples for VOC analysis will be sent to and analyzed by the laboratory. The samples for SVOC analysis will be held pending the SVOC results of the samples along the primary transect. These samples will be analyzed if the SVOC results from the corresponding sample along the primary profiling transect do not meet GQS'. For example, if the sample from*

~~location GWP-5 exceeds GQS' for SVOCs, then the sample from location GWP-13 will be analyzed for SVOCs; and if the sample from location GWP-13 exceeds GQS' for SVOCs, then the sample from GWP-18 will be analyzed for SVOCs. Refer to Section 7 for additional information on the planned analyses. The results of the samples along the initial transect will be used to determine whether to: step-in to locations on the secondary transect to the east (i.e., closer to WRR); or step-out to locations on the secondary transect to the west (i.e., closer to Route 111).~~

~~Groundwater samples from locations on the secondary transect will also be analyzed on an expedited basis in order to delineate the horizontal extent of dissolved phase groundwater impact in the investigation area. From this information, a brief plan with proposed monitoring well locations will be developed and submitted to IEPA for approval.~~

#### 4.3 CPT/ROST AND DIRECT PUSH SOIL SAMPLING

*Cone Penetrometer testing (CPT) and Rapid Optical Screening Tool (ROST) technologies will be performed at locations related to the delineation of the P-60 area (ROST-1 through ROST-18 shown in Figure 7).*

*CPT probes are completed by hydraulically pushing a cone, equipped with a pore pressure transducer, through the soil at a consistent rate of two centimeters per second (cm/s). The cone has a tip cross-sectional area of 15 cm<sup>2</sup> and the friction sleeve area of 200 cm<sup>2</sup>. Measurements are collected for resistance to penetration, sleeve friction and pore pressure once per second during advancement of each probe hole. These measurements provide soil property data, which are converted to a stratigraphic profile for each probe hole.*

*The ROST technology consists of a laser-induced fluorescence sensor, which consists of a small diameter sapphire window mounted flush with the side of a CPT probe. The down-hole ROST sensor is deployed utilizing the standard CPT technology described above. As the ROST sensor is advanced, the laser and associated equipment transmit pulses of light to the sensor through a fiber optic cable to the sapphire window. The pulsed light causes petroleum hydrocarbons in the soil to fluoresce, which travels through a second cable to a detection system within the CPT rig. Relative concentration and a spectral product fingerprint are presented continuously in real-time. Since fluorescence intensity is proportional to petroleum hydrocarbon concentration, ROST technology can effectively delineate the extent of affected soils.*

*Based on the CPT/ROST results, direct push soil sampling will be performed at selected*

locations (e.g., including those that indicate the potential presence of petroleum hydrocarbon NAPL) and gauging piezometers will be installed..

Soil sampling will also be performed at five locations in the area of the 1986 benzene release (GP-1 through GP-5 shown in **Figure 7**). Soil sampling will utilize a dual-tube sampling system for logging and sampling purposes (SOP 29 – Soil Probe Operation). The dual-tube system consists of a 4-foot long by 1.125-inch diameter clear acetate liner attached to 1-inch diameter inner rods. The acetate liner and inner rods are advanced simultaneously with the 2.125-inch diameter (minimum) outer rods. Once a sample is collected within the acetate liner, the inner rods and acetate liner are retrieved while the outer rods remain in place. The acetate liner is replaced and returned to the sampling depth, at which point the process is repeated.

The subsurface stratigraphy will be continuously logged (SOP 17 – Logging) by a qualified field scientist in accordance with the Unified Soil Classification System (USCS). The field scientist will note soil attributes such as color, particle size, consistency, moisture content, structure, plasticity, odor (if obvious), and organic content (if visible). Soil samples will also be screened in the field using a PID (SOP 14 – Head Space Soil Screening). Observations will be noted on the soil boring logs.

During probing of the proposed investigation locations in the area around the 1986 benzene release (GP-1 through GP-5), two or three soil samples per boring will be retained for analysis based upon field headspace PID readings and/or from more permeable zones (SOP 14 – Headspace Soil Screening and SOP 28 – Soil Sampling). Refer to **Section 7** for the planned analyses.

During probing at any of the locations related to the delineation of the P-60 area (e.g., ROST-1 through ROST-18), additional field screening will be conducted on selected soil samples using Sudan IV test kits in order to determine the presence of residual hydrocarbons in the soil. This additional method of field screening will be performed based upon CPT/ROST results, field headspace PID readings, visual observation of impact, and/or within more permeable zones. The Sudan IV test kits utilize a dye that stains petroleum products present in soil at concentrations roughly greater than or equal to about 500 parts per million (ppm), which should help determine the potential for free product to accumulate within a piezometer. Analytical testing of samples from these borings is not planned.

All soil borings will be advanced to groundwater, which is estimated to be approximately 40 to

50 feet bgs.

Upon completion of the soil borings in the area around the 1986 benzene release (GP-1 through GP-5), the borings will be backfilled with bentonite grout and the ground surface will be returned to its original condition (SOP 12 – Grouting Procedures). Prior to backfilling these borings, a groundwater sample may be collected from the drill rods at these locations.

Upon completion of the soil borings related to the delineation of the P-60 area (ROST-1 through ROST-18), a piezometer may be installed. The results of the CPT/ROST activities and any subsequent soil sampling at locations related to the delineation of the P-60 area will be used to define the locations for a network of product gauging piezometers (refer to **Section 4.5** for piezometer installation information). These field observations include, but are not limited to, CPT/ROST results, visual observations of product, a positive result from a Sudan IV test, and/or locations of more permeable zones. If no piezometer will be installed, the boring will be backfilled with bentonite grout and the ground surface will be returned to its original condition (SOP 12 – Grouting Procedures).

#### 4.4 MONITORING WELL INSTALLATION AND DEVELOPMENT

Monitoring wells will be installed at locations ~~sufficient~~ determined to provide value for longer term monitoring of the plume defined via profiling. This will ~~also~~ include monitoring wells along the perimeter of the area of impact identified via groundwater profiling and in the core of the previously identified benzene impact. This includes two wells ~~are~~ planned to be installed at the Roxana Public Works yard located south of Eighth Street (~~Figure 4 B-7 and B-8~~ shown in **Figure 7**) based on results of previous work. A brief plan with these proposed well locations will be developed and submitted to the IEPA for approval. The approach is to install these wells in the same field mobilization as the other activities described in this Plan.

Monitoring wells will be ~~drilled~~ installed utilizing 4.25-inch inner diameter hollow stem augers (SOP 21 – Monitoring Well Installation). If not previously logged, soil will be continuously collected and logged (SOP 17 – Logging) by a qualified field scientist in accordance with the Unified Soil Classification System (USCS) standards using a ~~2-foot~~ split-barrel sampler. The field scientist will note soil attributes such as color, particle size, consistency, moisture content, structure, plasticity, odor (if obvious), and organic content (if visible). The soil samples will be screened in the field using a photoionization detector (PID) (SOP 14 – Head Space Soil Screening). Observations will be noted on the soil boring logs.

The monitoring wells will be constructed of a 2-inch diameter Schedule 40 PVC casing, with a 10-foot section of 0.010-inch slotted PVC well screen. The exact placement of the well screens will be determined based upon the lithology encountered and historical groundwater information. The sand pack will consist of *placed or the* native sand in the water bearing stratum, and will extend to approximately 2 feet above the top of the well screen. *A minimum 3-foot thick bentonite seal will be placed above the sand pack.* The borehole annulus will then be grouted to the surface with high solids bentonite grout. Surface completions, including a locking expandable cap and flush-mount protector, will also be performed.

Once the monitoring well installations are complete, the wells will be developed in order to remove fines from the sand pack and screen (SOP 20 – Monitoring Well Development). The wells will be developed by pumping or bailing a minimum of five times the amount of any water introduced during probing (*i.e., bottom 20 feet*) plus five well volumes of water. During well development, water quality parameters including pH, temperature *and* conductivity ~~and turbidity~~ will be measured and recorded on field sheets after each well volume is removed (SOP 33 – Water Quality Monitoring). Development will continue until pH, temperature, and conductivity have stabilized over two consecutive well volumes and those well volumes are visually sediment-free.

#### 4.5 PIEZOMETER INSTALLATION

*Piezometers will be installed at CPT/ROST locations related to the delineation of the P-60 area where field observations suggest product may accumulate (e.g., ROST-1 through ROST-18 shown in **Figure 7**).*

*If a piezometer will be installed, the boring will be advanced an additional approximately 5 to 10 feet below the water table. The piezometers will be installed through dual tube casing and will be screened across the water table. The exact placement of the piezometer screens will be determined based upon the lithology encountered and historical groundwater information as well as the depth at which evidence of impact was noted.*

*The piezometers will consist of a 1.5-inch ID, variable length PVC screen and sand pack or pre-packed well screen, and riser, which will be installed through the outer casing of the drill rods. The specific screen length will be chosen based on field observations (e.g., CPT/ROST results, visual observations, Sudan test kit results, etc.). The annular space above the well screen will be filled with a bentonite chip seal and high solids bentonite slurry grout introduced as the outer rods are removed.*

*At each of these locations, a separate shallow piezometer may also be installed. The installation and depth of the shallow piezometers will be based on the potential presence of a shallower silty clay layer in the lithologic borings, and the potential presence of free product on this less permeable layer. The anticipated depth of any shallow piezometers is approximately 25 feet bgs. Soil samples will not be collected from these borings. Shallow piezometers will be installed and completed in a manner consistent with the methods described above for deeper piezometer installations.*

*It is not envisioned to develop the piezometers, since no groundwater samples are proposed to be collected from them. These piezometers are for the purpose of product gauging for the delineation of the P-60 area.*

#### 4.6 MONITORING WELL/PIEZOMETER GAUGING AND SAMPLING

After well development, sufficient time will be allowed for the new wells to equilibrate with the groundwater (approximately two weeks). A comprehensive round of gauging *will be performed and will include the newly installed wells and piezometers, the previously installed small diameter wells (MW-1 through MW-6), as well as selected WRR wells and piezometers near the western fenceline. A comprehensive round of groundwater and sampling will also be performed, and will include the newly installed wells, the previously installed small diameter wells (MW-1 through MW-6), as well as selected WRR wells near the western fenceline (Figure 7).*

The groundwater levels, product thickness (if present), and total depth of the wells will be measured and recorded on the field sheets (SOP 10 – Groundwater Level Measurements). Groundwater samples will not be collected from wells which exhibit measurable separate phase hydrocarbon (if any). During these gauging activities, the ambient and well-head VOC levels will be monitored.

The groundwater sampling will be performed using low-flow techniques as described below. Refer to **Section 7** for the planned analyses.

- Low-Flow Sampling – Groundwater sampling using low-flow procedures will follow SOP 18 – Low Flow Groundwater Purging and Sampling. For the monitoring wells (2-inch diameter or larger), a stainless steel submersible pump with the proper length of disposable polyethylene tubing will be slowly and carefully lowered into the well and set with the pump intake ~~near the mid-point of the screen or water column, whichever is deeper~~ *near the top of the well screen/water column, whichever is deeper.* For wells

smaller than 2-inch diameter, a stainless steel submersible bladder pump with the proper length of bonded disposable polyethylene tubing will be slowly and carefully lowered into the well and set with the pump intake ~~near the mid-point of the screen or water column, whichever is deeper~~ *near the top of the well screen/water column, whichever is deeper*. Collecting samples from near the top of the well screen/water column should represent the most impacted conditions. The tubing from the pump will be connected to a flow-through cell, which will discharge into a five-gallon plastic bucket. Pumping will be performed at a low flow rate (<500 ml/minute) so as to not create drawdown of the water level within the well. During purging, water quality parameters (pH, temperature, conductivity, turbidity, DO, and ORP) will be measured in the field and recorded on field sheets after every flow-through cell volume (SOP 33-Water Quality Monitoring). Purging will continue until a minimum of three flow-through cell volumes of water have been removed and the water quality parameters have stabilized. Once stabilization is achieved, the groundwater flow will be diverted from the flow-through cell and the groundwater will be sampled. *Monitoring wells will be sampled for analysis of VOCs and SVOCs.*

HydraSleeve® passive groundwater samplers will also be used on a subset of the samples for potential future use in replacing the *above* sampling methodology.

- HydraSleeve Samplers – Groundwater sampling using no-purge procedures will follow SOP 45 – Passive Groundwater Sampling using HydraSleeve. These passive samplers will be lowered into the well and positioned to collect a groundwater sample from ~~the mid-section of the well screen~~ *near the top of the well screen or water column, whichever is deeper*. When activated, the HydraSleeve® will yield a representative water sample from an approximately 2.5 to 3-foot interval without mixing fluid from other intervals. *To the extent possible, this sampling interval will be biased toward to top of the water column* ~~entered at the mid-point of the well screen~~. Once the sampler is full, the one-way reed valve will collapse, preventing mixing of extraneous, non-representative fluid during recovery. A short plastic discharge tube will then be used to fill sample containers. *Hydrosleeve samples will be sampled for analysis of VOCs and SVOCs.*

Once the HydraSleeve® is removed from the well, the ~~probe~~ sonde from a water quality meter will be placed down-hole to measure water quality parameters (e.g., pH, temperature, conductivity, DO, and ORP). Refer to the HydraSleeve field manual in ~~Attachment A~~ *Attachment D* for further information.

#### 4.7 VAPOR MONITORING POINT INSTALLATION

A vapor monitoring point (VMP) with four discrete vapor monitoring ports will be installed at ~~each~~ most of the ~~investigation locations intersections~~ along the eastern secondary transect (i.e., nearest the WRR west fence line) as shown on ~~Figure 4~~ **Chaffer Street** (VMP-1 through VMP-7 shown in **Figure 7**). VMPs will also be installed adjacent to existing well MW-4 (VMP-8 shown in **Figure 7**), and at the east end of that same alley near Chaffer Street (~~Figure 4~~ VMP-9 shown in **Figure 7**). Additionally, VMPs may also be installed at locations adjacent to proposed monitoring wells. The ports at each of the VMP locations are planned to be installed at four depths throughout the unsaturated zone: 5 feet; 10 feet; and the remaining two evenly distributed between 10 feet and groundwater.

The vapor monitoring ports at each VMP location will be installed *together* in a hollow-stem auger or Geoprobe® boring. Each vapor monitoring port will consist of a 0.5-inch outer diameter by 6-inch long Geoprobe® Systems stainless steel screen connected to a 0.125-inch diameter stainless steel or teflon riser tubing extending to the ground surface. A sand pack will be placed in the annular space from approximately six inches below to six inches above each stainless steel screen. Granular bentonite seals will be placed between individual vapor monitoring port screen/sand pack intervals. The remaining annular space will be filled with grout to the ground surface and completed at the surface with a flush-mounted protective cover.

#### 4.8 VAPOR MONITORING POINT SAMPLING

VMP sampling activities will be performed at the newly installed vapor ports at each of the VMP locations (VMP-1 through VMP-9 shown in **Figure 7**). *Vapor sampling will be performed according to SOP 44 – Soil Vapor Purging and Sampling.*

Prior to sampling from a vapor port, the vacuum/pressure reading will be collected utilizing a digital manometer. Three well volumes of air will then be purged from the vapor port using a 60 milliliter (mL) syringe. During the purging process, if water is encountered or drawback of the syringe plunger occurs, this will be noted and the sampling process will cease.

Once purging is completed, *an unused summa canister is selected and the pressure gauge assembly is used to verify the summa canister vacuum.* The summa canister sampling assembly, with flow controller, *is attached to the vapor port with an unused length of Teflon tubing and will be setup in such a way as to allow extraction from the monitoring port only and shut off from the atmosphere.*

*A leak detection system will be utilized during vapor sampling to determine whether leakage has occurred. The leak detection system will be via one of two methods:*

- *One method uses helium gas as a tracer and allows for the assessment of potential probe leak prior to and during sample collection.*
- *The other method utilizes isopropyl alcohol as a tracer and allows for the assessment of potential probe leak after sample collection and analysis.*

Once the sample summa canister is filled, a Tedlar bag will be filled using a peristaltic pump *and Teflon tubing*. A rotometer will be used to adjust the flow of vapor to a rate less than or equal to 200 mL/min. When the proper flow rate is achieved, the Tedlar bag will be attached and filled with the vapor. This vapor sample will then be screened in the field for total VOCs via a PID, and for oxygen, carbon monoxide, hydrogen sulfide and the lower explosive limit via a 4-gas meter. ~~All of~~ The information collected in the field will be recorded on the field sheets. Refer to **Section 7** for the planned laboratory analyses.

#### 4.9 DIRECT PUSH SOIL SAMPLING

~~Soil sampling will be performed in the area of the 1986 benzene release (Figure 3). Soil sampling will utilize a dual-tube sampling system for logging and sampling purposes (SOP 29—Soil Probe Operation). The dual-tube system consists of a 4-foot long by 1.125-inch diameter clear acetate liner attached to 1-inch diameter inner rods. The acetate liner and inner rods are advanced simultaneously with the 2.125-inch diameter outer rods. Once a sample is collected within the acetate liner, the inner rods and acetate liner are retrieved while the outer rods remain in place. The acetate liner is replaced and returned to the sampling depth, at which point the process is repeated.~~

~~The subsurface stratigraphy will be continuously logged (SOP 17—Logging) by a qualified field scientist in accordance with the Unified Soil Classification System (USCS). The field scientist will note soil attributes such as color, particle size, consistency, moisture content, structure, plasticity, odor (if obvious), and organic content (if visible). The soil samples will also be screened in the field using a PID (SOP 14—Head Space Soil Screening). Observations will be noted on the soil boring logs.~~

~~These soil borings will extend to the groundwater table (approximately 40 feet bgs). Prior to~~

~~backfilling, a groundwater sample may be collected from these locations.~~

~~Upon completion, the borings will be backfilled with bentonite grout and the ground surface will be returned to its original location (SOP 12—Grouting Procedures).~~

~~During sampling proposed investigation locations, two or three soil samples may be retained for analysis based upon field headspace PID readings and/or from more permeable zones (SOP 14—Headspace Soil Screening and SOP 28—Soil Sampling). Refer to **Section 7** for the planned analyses.~~

### 4.9 SURVEYING

The investigation locations, monitoring wells, and VMP locations will be surveyed upon completion. *At a minimum, for monitoring wells, piezometers and VMPs*, the horizontal coordinates will be determined for each location relative to the Illinois State Plane Coordinates (NAD 83), and the elevations will be determined using the 1988 USGS datum.

Personnel conducting the sampling will wear clean disposable protective gloves. Sample containers will be labeled with a sample ID number, site name, sampler initials, sample date and time, sample preservative, and the parameters to be analyzed. After sample collection, the samples will be logged on a chain-of-custody (COC) form, packaged to prevent damage during shipment, and cooled to 4°C (except vapor samples, which are not shipped on ice). The samples will then be delivered, under the proper COC documentation, to the appropriate laboratory via *overnight* delivery or courier service. Refer to SOP 24 – Sample Classification, Packaging, and Shipping (DOT), SOP 25 – Sample Containers, Preservation, and Holding Times and SOP 26 – Sample Control and Custody Procedures. Due to the potential flammable nature of the vapor within the summa canisters, the soil vapor samples will be shipped ~~via air~~ according to all applicable regulations as required by the International Civil Aviation Organization (ICAO).

Laboratories proposed for this scope of work include:

- Teklab, Inc., Collinsville, IL – expedited turnaround for groundwater profile samples (*SVOC analysis*).
- Xenco Laboratories, Inc., Stafford, TX – routine analysis of soil and groundwater samples.
- Air Toxics, Folsom, CA – routine analysis of soil vapor samples.

The data from the field activities will be collected in accordance with the procedures described in this work plan. Quality assurance samples in the form of duplicates, trip blanks, and matrix spike and matrix spike duplicates (MS/MSD) will be collected (SOP 23-Quality Assurance Samples). Duplicates of selected samples will be collected and analyzed from 10 percent of the sample locations to check for sampling and analytical reproducibility. MS and MSD samples will be collected and analyzed from 5 percent of the sample locations to evaluate the effect of the sample matrix on the accuracy of the analysis. ~~Trip blanks will be collected and analyzed on a daily basis to assess VOC cross contamination of samples during shipment to the laboratory. A trip blank will be collected and included in each cooler containing samples for VOC analysis. A minimum of one trip blank set for every 10 investigative samples will be collected.~~ The trip blank will consist of *two 40-mL* ~~one or more~~ VOA vials prepared by the laboratory, transported to the field, and shipped with the other samples to the laboratory. The trip blanks will not be opened in the field. Equipment blanks will also be collected and analyzed from 10 percent of the sample locations if non-dedicated or non-expendable equipment are used.

Field personnel will wear Level D personal protective equipment (PPE) with the potential to upgrade to USEPA Modified Level D or Level C if site conditions warrant. *While work is being performed within the WRR, flame resistant clothing (FRCs) will be worn by URS personnel and subcontractors.* A PID with a 10.2 electron volt (eV) probe and combustible gas indicator (CGI) will be used during the field activities to monitor air quality for health and safety purposes. Field instruments will be calibrated prior to each use in accordance with the manufacturer's specifications. Health and safety related information will be primarily recorded in field logbooks. For work conducted on the WRR, COP personnel may inspect the work areas and monitor the ambient air, as necessary prior to the issuance of daily work permits in areas where they are required.

Field personnel and equipment will undergo decontamination procedures to ensure the health and safety of those present, to maintain sample integrity, and to minimize cross contamination between sampling locations (SOP 4 – Decontamination). Reusable sampling equipment (e.g., *drilling rods*, groundwater pumps) will be decontaminated between each sampling location by washing with Alconox®, LiquiNox®, or equivalent detergent wash, a desorbing agent (i.e. isopropyl alcohol), and a distilled water rinse. Personnel and small equipment decontamination will be performed at the sample locations. Drill rods will be decontaminated prior to the drilling of each new borehole with a high-pressure hot water wash. The washing will be conducted on a temporary decontamination station ~~at the Roxana Public Works yard~~ *in the investigation area.* Decontamination fluids *generated outside the WRR* will be collected and staged on-site in 55-gallon drums for proper disposal. *Decontamination fluids generated from inside of the WRR will be disposed through the refinery's NPDES-permitted Wastewater Treatment Plant (WWTP).*

Investigative derived waste (IDW) including soil cuttings, PPE, and expendable materials will be collected and disposed of properly (SOP 16 – IDW Handling). Expendable materials (e.g., disposable sampling equipment, such as gloves and tubing) having a low probability of contamination will be collected in trash bags and disposed of as municipal waste. Impacted expendable materials and soil cuttings will be collected and placed in labeled and sealed 55-gallon drums or directly into roll-offs for future disposal. *Solids generated from borings outside the WRR will be collected and staged at the Village of Roxana Public Works yard. Solids generated from inside the WRR will be managed by current site owner representatives on behalf of SOPUS.* Prior to disposal, the soil cuttings and purge water ~~will~~ *may* be sampled for waste characterization as part of the disposal profile process.

## **SECTION SIX**

### Procedures and Investigation-Derived Waste Handling

~~IDW possibly generated while sampling ConocoPhillips wells or conducting intrusive activities within the WRR will be disposed of in accordance with WRR procedures.~~

Field data and documentation will become a part of the project file. URS will be the custodian of the file and maintain the contents of files for the site, including all relevant records, logs, field logbooks, pictures, subcontractor reports, data reviews, and the database management system.

The following documentation will supplement the chain-of-custody records:

- Field logbooks and data
- Field sample collection sheets
- Photographs and drawings
- Soil boring and well construction logs
- Contractor and subcontractor reports
- Correspondence.

Analytical data will be provided in hard copy and electronic formats. Electronic data will be loaded into a database to facilitate data evaluation and reporting. The data presented in the report will include the data flags provided by *the laboratories Xeneo* as well as the qualifiers assigned by the data reviewer.

~~The reporting list for this project will be the volatile organic compounds (VOCs) included on the USEPA Region 5 "Skinner List". The Skinner List includes petroleum refinery related hazardous constituents. Refined petroleum products are stored in the WRR's North Tank Farm, and as such, VOCs are an appropriate analytical suite.~~

Soil and groundwater samples will be analyzed for VOCs via SW-846 Method 8260B. Groundwater samples will also be analyzed for SVOCs including polycyclic aromatic hydrocarbons (PAHs) via SW-846 Method 8270C. ~~and the following constituents will be reported.~~

- |                                      |                                 |
|--------------------------------------|---------------------------------|
| • <del>Benzene</del>                 | • <del>Styrene</del>            |
| • <del>Carbon disulfide</del>        | • <del>Toluene</del>            |
| • <del>Chlorobenzene</del>           | • <del>1,1-Dichloroethane</del> |
| • <del>Chloroform</del>              | • <del>1,2-Dichloroethane</del> |
| • <del>Methyl ethyl ketone</del>     | • <del>1,4-Dioxane</del>        |
| • <del>Methyl tert-butyl Ether</del> | • <del>Ethylbenzene</del>       |

- Ethylene dibromide (EDB)
- Tetrachloroethylene
- 1,1,1-Trichloroethane
- Trichloroethene
- Xylenes (total)

*The following analytical approach is proposed for groundwater profiling:*

- *Groundwater samples from each profiling location will be collected and analyzed by the laboratory for VOCs.*
- *Groundwater samples from profiling locations along the primary profiling transect (GWP-1 through GWP-10 shown in **Figure 7**) will be collected and analyzed for SVOCs on an expedited basis via local laboratory. These results will then be compared to the GQS' presented in **Table 6**. If the results from a location are less than the GQS', then the samples from the locations directly to the west (along the secondary and tertiary profiling transects shown in **Figure 7**) will not be analyzed for SVOCs.*
- *Depending on the pace of groundwater profiling and sampling, decision-making, and other logistical factors, sample bottles for SVOC analysis may be filled for locations along the secondary (GWP-11 through GWP-15) and tertiary (GWP-16 through GWP-20) profiling transects. If this occurs, the samples will be sent to the laboratory and held, as necessary, to complete the process.*

Soil vapor samples will be analyzed for VOCs via Method TO-15 ~~using the same reporting list as for soil and groundwater samples.~~ Vapor samples will also be analyzed for relevant gases such as carbon dioxide, carbon monoxide, ethane, ethene, methane, nitrogen, and oxygen, etc. via ASTM D-1946.

URS will work with the laboratory to attain reporting limits to meet the project objectives, however, due to technical constraints, achieving reporting limits that are lower than the screening levels might not be feasible for all compounds. Analytical data from the sampling will be independently reviewed and qualified by URS. A Level III validation will be performed on all data.

Analytical results for soil and groundwater will be compared to the latest version of the TACO screening levels in ~~Table 4~~ **Tables 5 and 6**. Data from soil vapor samples will be evaluated using IEPA's ~~draft Guidance for Evaluating the Indoor Inhalation Exposure Route using TACO Principles, dated May 2007~~ proposed amendments to TACO for soil gas (**Table 7**).

A report will be prepared summarizing and providing documentation of the field work and collected data. The report will include tables, figures, boring logs and supporting information (e.g., laboratory data). The report will present an evaluation of the nature and extent of impact and will discuss possible future actions.

The proposed project schedule on the following page provides an approximate sequence for the activities described in this plan, taking into account potential delays associated with, but not limited to, weather, contractor availability, access issues, etc. This schedule will be reviewed and revised if necessary following IEPA's approval of this plan.

**Project Schedule**  
**Dissolved Phase Groundwater Investigation and P-60 Product Delineation**  
**Roxana, Illinois**

ACTIVITY	Week																							
	1	2	3	4	5	6	7	8	9	10	11	12	13	14	15	16	17	18	19	20	21	22	23	24
Initiate Investigation (After IEPA approval))																								
Pre-Field Activities																								
Borehole Utility Clearing (Hand Auger/Air-Knifing)																								
Groundwater Profiling																								
CPT/ROST and Direct Push Soil Sampling																								
Direct Push Soil Sampling & Piezometer Installation																								
Submit Planned Well Locations to IEPA/Discuss																								
Monitoring Well Installations & Development																								
Groundwater Gauging & Sampling																								
Vapor Monitoring Point Installation																								
Vapor Monitoring Point Sampling																								
Surveying																								
Laboratory Testing																								
Data Analysis & Report Preparation																								
Submit Report to IEPA																								■

- Notes:**
- The scope of piezometer installations is not defined at this time. The schedule will be reviewed/revised once the scope has been determined.
  - The scope of monitoring well installations is not defined at this time. The schedule will be reviewed/revised once the scope has been determined.
  - The schedule is subject to revisions, pending potential delays associated with, but not limited to, weather, contractor availability, access issues, etc.
  - The schedule will be revised as appropriate once IEPA approves the work plan.



**TABLE 1  
CONOCOPHILLIPS QUARTERLY GAUGING DATA - WEST FENCELINE WELLS (1Q07 - 2Q08)**

Well ID	TOC Elevation	Gauging Event	DTP (btoc)	DTW (btoc)	Product Thickness (ft)	Corrected Water Elevation
P-54	442.97	1Q07	NE	48.50	NA	394.47
		2Q07	NE	48.45	NA	394.52
		3Q07	NE	47.88	NA	395.09
		4Q07	NE	48.34	NA	394.63
		1Q08	NE	48.99	NA	393.98
		2Q08	NE	56.50	NA	396.47
P-55	446.67	1Q07	NG	NG	NA	NA
		2Q07	NE	52.95	NA	393.72
		3Q07	NE	52.74	NA	393.93
		4Q07	NG	NG	NA	NA
		1Q08	NG	NG	NA	NA
		2Q08	NE	53.26	NA	393.41
P-56	446.73	1Q07	NE	53.28	NA	393.45
		2Q07	52.36	53.39	1.03	394.16
		3Q07	NE	52.95	NA	393.78
		4Q07	NE	53.24	NA	393.49
		1Q08	NE	53.91	NA	392.82
		2Q08	NE	53.24	NA	393.49
P-57	447.22	1Q07	NG	NG	NA	NA
		2Q07	NG	NG	NA	NA
		3Q07	NE	52.89	NA	394.33
		4Q07	NE	53.12	NA	394.10
		1Q08	NG	NG	NA	NA
		2Q08	NE	52.97	NA	394.25
P-58	445.60	1Q07	50.89	52.79	1.90	394.33
		2Q07	50.71	52.01	1.30	394.63
		3Q07	50.60	51.89	1.29	394.74
		4Q07	50.81	52.74	1.93	394.40
		1Q08	51.04	53.40	2.36	394.09
		2Q08	50.67	51.46	0.79	394.77
P-59	447.53	1Q07	53.99	55.14	1.15	393.31
		2Q07	54.11	55.33	1.22	393.18
		3Q07	53.83	54.24	0.41	393.62
		4Q07	54.03	54.82	0.79	393.34
		1Q08	54.79	56.07	1.28	392.48
		2Q08	54.29	54.40	0.11	393.22
P-60	446.78	1Q07	51.89	60.09	8.20	393.25
		2Q07	52.65	60.02	7.37	392.66
		3Q07	51.45	60.01	8.56	393.62
		4Q07	52.09	59.09	7.00	393.29
		1Q08	NG	NG	NA	NA
		2Q08	52.84	58.81	5.97	392.75
P-66	437.46	1Q07	42.36	44.18	1.82	394.74
		2Q07	42.21	43.26	1.05	395.04
		3Q07	42.13	43.10	0.97	395.14
		4Q07	52.34	43.89	-8.45	394.81
		1Q08	42.51	44.34	1.83	394.58
		2Q08	42.06	42.70	0.64	395.27
P-93A	447.30	1Q07	NE	53.09	NA	394.21
		2Q07	NE	52.83	NA	394.47
		3Q07	NE	52.81	NA	394.49
		4Q07	NE	53.14	NA	394.16
		1Q08	NE	53.66	NA	393.77
		2Q08	NE	52.76	NA	394.67
T-1	444.25	1Q07	NE	49.72	NA	394.53
		2Q07	NE	50.28	NA	393.97
		3Q07	NE	50.15	NA	394.10
		4Q07	NE	40.19	NA	394.06
		1Q08	NE	50.58	NA	393.67
		2Q08	NE	50.82	NA	393.43
T-6	451.61	1Q07	NE	53.36	NA	393.88
		2Q07	NE	53.24	NA	394.00
		3Q07	52.11	52.15	0.04	395.12
		4Q07	NE	54.35	NA	392.89
		1Q08	NE	53.76	NA	393.48
		2Q08	NE	53.18	NA	394.06
T-12	445.41	1Q07	52.36	53.01	0.65	392.92
		2Q07	52.95	53.55	0.60	392.34
		3Q07	52.11	52.15	0.04	393.29
		4Q07	52.49	52.54	0.05	392.91
		1Q08	53.48	54.93	1.45	391.64
		2Q08	52.85	52.87	0.02	392.56
T-13	444.19	1Q07	NE	49.62	NA	394.57
		2Q07	NE	49.90	NA	394.29
		3Q07	NE	49.67	NA	394.52
		4Q07	NE	49.96	NA	394.23
		1Q08	NE	50.32	NA	393.87
		2Q08	NE	50.22	NA	393.97

NE = Not Encountered  
NG = Not Gauged  
NA = Not Applicable

**SOURCE:** WRB provided the groundwater gauging information shown above.

**TABLE 2  
2006 WELL & PIEZOMETER GAUGING DATA**

Well/PZ ID	Screen Length (ft)	Set Bottom Depth (bgs)	Date Gauged	DTP (btoc)	DTW (btoc)	Product Thickness (ft)	Notes
P-60	20	65.00	04/17/06	NG	NG	NA	
			04/18/06	NG	NG	NA	
			04/19/06	NG	NG	NA	
			04/27/06	NE	49.04	NA	Staining and odor observed.
			05/05/06	49.14	60.26	11.12	Staining and odor observed.
			06/05/07	52.37	59.91	7.54	Staining and odor observed.
			08/08/08	48.37	58.40	10.03	
P-60-8	10	20.00	04/17/06	18.10	19.00	0.90	No product tone given by interface probe, but 0.9 ft of probe stained with product.
			04/18/06	18.80	18.82	0.02	Strong odor observed.
			04/19/06	NG	NG	NA	
			04/27/06	NE	18.81	NA	
			05/05/06	18.59	18.61	0.02	Staining and odor observed.
			06/05/07	11.78	12.28	0.50	No product tone given by interface probe, but 0.5 ft of probe stained with product.
			08/08/08	11.40	12.90	1.50	No product tone given by interface probe, but 1.5 ft of probe stained with product.
P-60-9	15	56.00	04/17/06	NG	NG	NA	
			04/18/06	NG	NG	NA	
			04/19/06	NG	NG	NA	
			04/27/06	NE	NE	NA	
			05/05/06	NE	44.75	NA	Highly sedimented
			06/05/07	49.20	50.35	1.15	Soft bottom
			08/08/08	43.78	49.13	5.35	
P-60-10	10	46.00	04/17/06	NG	NG	NA	
			04/18/06	NE	45.12	NA	
			04/19/06	NE	NE	NA	
			04/27/06	NE	45.12	NA	
			05/05/06	NE	38.61	NA	Highly sedimented
			06/05/07	NG	NG	NA	Unable to locate piezometer. Piezometer covered by gravel.
			08/08/08	NG	NG	NA	Unable to locate piezometer. Piezometer covered by gravel.
P-60-11	15	65.00	04/17/06	NG	NG	NA	
			04/18/06	65.23	48.83	0.08	Strong odor observed.
			04/19/06	NG	NG	NA	
			04/27/06	NE	49.00	NA	
			05/05/06	NE	48.94	NA	Piezometer under pressure.
			06/05/07	51.05	52.56	1.51	
			08/08/08	47.90	49.10	1.20	
P-60-12	10	71.00	04/17/06	NE	53.68	NA	
			04/18/06	48.98	49.00	0.02	
			04/19/06	NG	NG	NA	
			04/27/06	NE	49.12	NA	
			05/05/06	49.11	49.13	0.02	
			06/05/07	NE	51.52	NA	
			08/08/08	NE	48.12	NA	
P-60-12S	10	24.00	04/17/06	NG	NG	NA	
			04/18/06	NG	NG	NA	
			04/19/06	NG	NG	NA	
			04/27/06	NE	NE	NA	
			05/05/06	NE	NE	NA	
			06/05/07	NE	23.09	NA	
			08/08/08	21.70	22.41	0.71	

NE = Not Encountered  
 NG = Not Gauged  
 NA = Not Applicable

**TABLE 3  
SUMMARY OF GROUNDWATER ANALYTICAL DETECTIONS AND SCREENING**

SCREENING VALUE EXCEEDANCES ARE HIGHLIGHTED YELLOW

Analyte			Benzene	Ethylbenzene	Toluene	o-Xylene	m,p-Xylene	1,2,4-Trimethylbenzene	1,3,5-Trimethylbenzene	Isopropylbenzene
Ingestion Screening Values (mg/L)			0.005	0.7	1.0	10		0.35*	0.35*	0.66**
Location	Sample ID	Date	ANALYTICAL RESULTS (mg/L)							
P-55	P-55080808	8/8/2008	<b>0.686 D</b>	<b>0.921 D</b>	<b>0.350 D</b>	<b>0.118</b>	<b>1.78 D</b>	<b>0.403 D</b>	<b>0.0936</b>	<b>0.0537</b>
T-1	T-1080808	8/8/2008	<0.005	<0.005	<0.005	<0.005	<0.010	<0.005	<0.005	<0.005
T-13	T-13080808	8/8/2008	<0.005	<0.005	<0.005	<0.005	<0.010	<0.005	<0.005	<0.005

Analyte			Methyl tert-Butyl Ether	Methylene Chloride	Naphthalene	n-Propylbenzene	n-Butylbenzene	p-Isopropyltoluene	sec-Butylbenzene
Ingestion Screening Values (mg/L)			0.07	0.005	0.14	0.24***	0.24***		0.24***
Location	Sample ID	Date	ANALYTICAL RESULTS (mg/L)						
P-55	P-55080808	8/8/2008	<0.005	<b>0.00218 J</b>	<b>0.149 D</b>	<b>0.0873</b>	<b>0.0111</b>	<b>0.0043 J</b>	<b>0.00738</b>
T-1	T-1080808	8/8/2008	<0.005	<b>0.00314 J</b>	<0.010	<0.005	<0.005	<0.005	<0.005
T-13	T-13080808	8/8/2008	<0.005	<b>0.00283 J</b>	<0.005	<0.005	<0.005	<0.005	<0.005

**NOTES:**

- 1) Sample ID explanation --> X-XXDDDDDD --> X-XX is the well location at which the sample was collected; DDDDDDD is the date on which the sample was collected.
- 2) <#.## Denotes the analyte was not detected below the indicated reporting limit.
- 3) The screening value provided is for Xylenes (total), which is the summation of o-Xylenes and m,p-Xylenes.

**LAB QUALIFIERS:**

D = The samples were diluted due to targets detected over the highest point of the calibration curve, or due to matrix interference. Dilution factors are included in the final results. The result is from a diluted sample.  
 J = The target analyte was positively identified below the reporting limit (RL) and above the method detection limit (MDL).

**REFERENCES:**

Illinois Environmental Protection Agency (IEPA); Tiered Approach to Corrective Action Objectives (TACO); Title 35 of the Illinois Administrative Code, Part 742, Appendix B, Table E.

\* IEPA; TACO; Groundwater Remediation Objectives for Chemicals not listed in TACO; dated May 1, 2007.

\*\* U.S. Environmental Protection Agency (USEPA); Region 6 Human Health Medium-Specific Screening Levels; dated December 2007.

\*\*\* USEPA; Region 9 Preliminary Remediation Goals (PRGs) Table; dated October 2004.

**TABLE 4  
INVESTIGATION LOCATION ACTIVITY SUMMARY TABLE**

Sample Location	Sample ID	Purpose/Method	Sample Type	Analysis	Additional Notes
Primary Transect	GWP-1	Groundwater Profile	2 groundwater grab samples (1- top of water table; 1-approximately 8 ft deeper)	VOCs, SVOCs	SVOCs on expedited turnaround
Primary Transect	GWP-2	Groundwater Profile	2 groundwater grab samples (1- top of water table; 1-approximately 8 ft deeper)	VOCs, SVOCs	SVOCs on expedited turnaround
Primary Transect	GWP-3	Groundwater Profile	2 groundwater grab samples (1- top of water table; 1-approximately 8 ft deeper)	VOCs, SVOCs	SVOCs on expedited turnaround
Primary Transect	GWP-4	Groundwater Profile	2 groundwater grab samples (1- top of water table; 1-approximately 8 ft deeper)	VOCs, SVOCs	SVOCs on expedited turnaround
Primary Transect	GWP-5	Groundwater Profile	2 groundwater grab samples (1- top of water table; 1-approximately 8 ft deeper)	VOCs, SVOCs	SVOCs on expedited turnaround
Primary Transect	GWP-6	Groundwater Profile	2 groundwater grab samples (1- top of water table; 1-approximately 8 ft deeper)	VOCs, SVOCs	SVOCs on expedited turnaround
Primary Transect	GWP-7	Groundwater Profile	2 groundwater grab samples (1- top of water table; 1-approximately 8 ft deeper)	VOCs, SVOCs	SVOCs on expedited turnaround
Primary Transect	GWP-8	Groundwater Profile	2 groundwater grab samples (1- top of water table; 1-approximately 8 ft deeper)	VOCs, SVOCs	SVOCs on expedited turnaround
Primary Transect	GWP-9	Groundwater Profile	2 groundwater grab samples (1- top of water table; 1-approximately 8 ft deeper)	VOCs, SVOCs	SVOCs on expedited turnaround
Primary Transect	GWP-10	Groundwater Profile	2 groundwater grab samples (1- top of water table; 1-approximately 8 ft deeper)	VOCs, SVOCs	SVOCs on expedited turnaround
Secondary Transect	GWP-11	Groundwater Profile	2 groundwater grab samples (1- top of water table; 1-approximately 8 ft deeper)	VOCs, (SVOCs)	SVOCs analyzed only if Primary Transect samples exceed GQSs
Secondary Transect	GWP-12	Groundwater Profile	2 groundwater grab samples (1- top of water table; 1-approximately 8 ft deeper)	VOCs, (SVOCs)	SVOCs analyzed only if Primary Transect samples exceed GQSs
Secondary Transect	GWP-13	Groundwater Profile	2 groundwater grab samples (1- top of water table; 1-approximately 8 ft deeper)	VOCs, (SVOCs)	SVOCs analyzed only if Primary Transect samples exceed GQSs
Secondary Transect	GWP-14	Groundwater Profile	2 groundwater grab samples (1- top of water table; 1-approximately 8 ft deeper)	VOCs, (SVOCs)	SVOCs analyzed only if Primary Transect samples exceed GQSs
Secondary Transect	GWP-15	Groundwater Profile	2 groundwater grab samples (1- top of water table; 1-approximately 8 ft deeper)	VOCs, (SVOCs)	SVOCs analyzed only if Primary Transect samples exceed GQSs
Tertiary Transect	GWP-16	Groundwater Profile	2 groundwater grab samples (1- top of water table; 1-approximately 8 ft deeper)	VOCs, (SVOCs)	SVOCs analyzed only if Primary Transect samples exceed GQSs
Tertiary Transect	GWP-17	Groundwater Profile	2 groundwater grab samples (1- top of water table; 1-approximately 8 ft deeper)	VOCs, (SVOCs)	SVOCs analyzed only if Primary Transect samples exceed GQSs
Tertiary Transect	GWP-18	Groundwater Profile	2 groundwater grab samples (1- top of water table; 1-approximately 8 ft deeper)	VOCs, (SVOCs)	SVOCs analyzed only if Primary Transect samples exceed GQSs
Tertiary Transect	GWP-19	Groundwater Profile	2 groundwater grab samples (1- top of water table; 1-approximately 8 ft deeper)	VOCs, (SVOCs)	SVOCs analyzed only if Primary Transect samples exceed GQSs
Tertiary Transect	GWP-20	Groundwater Profile	2 groundwater grab samples (1- top of water table; 1-approximately 8 ft deeper)	VOCs, (SVOCs)	SVOCs analyzed only if Primary Transect samples exceed GQSs
North of 1986 Release	GWP-21	Groundwater Profile	2 groundwater grab samples (1- top of water table; 1-approximately 8 ft deeper)	VOCs, (SVOCs)	
Near 1986 Release	GP-1	Direct Push Soil Boring	2-3 soil grab samples based on PID headspace readings/permeable zones	VOCs	Possible groundwater sample if evidence of impact (VOCs)
Near 1986 Release	GP-2	Direct Push Soil Boring	2-3 soil grab samples based on PID headspace readings/permeable zones	VOCs	Possible groundwater sample if evidence of impact (VOCs)
Near 1986 Release	GP-3	Direct Push Soil Boring	2-3 soil grab samples based on PID headspace readings/permeable zones	VOCs	Possible groundwater sample if evidence of impact (VOCs)
Near 1986 Release	GP-4	Direct Push Soil Boring	2-3 soil grab samples based on PID headspace readings/permeable zones	VOCs	Possible groundwater sample if evidence of impact (VOCs)
Near 1986 Release	GP-5	Direct Push Soil Boring	2-3 soil grab samples based on PID headspace readings/permeable zones	VOCs	Possible groundwater sample if evidence of impact (VOCs)
Chaffer Street	ROST-1	CPT/ROST (P-60 Area Delineation)	Possible visual observation and field screening if soil sampling performed	Sudan IV field test kit	1.5-in. Piezometer may be installed if field observations suggest product may accumulate
Third Street	ROST-2	CPT/ROST (P-60 Area Delineation)	Possible visual observation and field screening if soil sampling performed	Sudan IV field test kit	1.5-in. Piezometer may be installed if field observations suggest product may accumulate
Third Street	ROST-3	CPT/ROST (P-60 Area Delineation)	Possible visual observation and field screening if soil sampling performed	Sudan IV field test kit	1.5-in. Piezometer may be installed if field observations suggest product may accumulate
Chaffer Street	ROST-4	CPT/ROST (P-60 Area Delineation)	Possible visual observation and field screening if soil sampling performed	Sudan IV field test kit	1.5-in. Piezometer may be installed if field observations suggest product may accumulate
Chaffer Street	ROST-5	CPT/ROST (P-60 Area Delineation)	Possible visual observation and field screening if soil sampling performed	Sudan IV field test kit	1.5-in. Piezometer may be installed if field observations suggest product may accumulate
Fourth Street	ROST-6	CPT/ROST (P-60 Area Delineation)	Possible visual observation and field screening if soil sampling performed	Sudan IV field test kit	1.5-in. Piezometer may be installed if field observations suggest product may accumulate
Fourth Street	ROST-7	CPT/ROST (P-60 Area Delineation)	Possible visual observation and field screening if soil sampling performed	Sudan IV field test kit	1.5-in. Piezometer may be installed if field observations suggest product may accumulate
Chaffer Street	ROST-8	CPT/ROST (P-60 Area Delineation)	Possible visual observation and field screening if soil sampling performed	Sudan IV field test kit	1.5-in. Piezometer may be installed if field observations suggest product may accumulate
Chaffer Street	ROST-9	CPT/ROST (P-60 Area Delineation)	Possible visual observation and field screening if soil sampling performed	Sudan IV field test kit	1.5-in. Piezometer may be installed if field observations suggest product may accumulate
Chaffer Street	ROST-10	CPT/ROST (P-60 Area Delineation)	Possible visual observation and field screening if soil sampling performed	Sudan IV field test kit	1.5-in. Piezometer may be installed if field observations suggest product may accumulate
WRR	ROST-11	CPT/ROST (P-60 Area Delineation)	Possible visual observation and field screening if soil sampling performed	Sudan IV field test kit	1.5-in. Piezometer may be installed if field observations suggest product may accumulate

**TABLE 4  
INVESTIGATION LOCATION ACTIVITY SUMMARY TABLE**

Sample Location	Sample ID	Purpose/Method	Sample Type	Analysis	Additional Notes
WRR	ROST-12	CPT/ROST (P-60 Area Delineation)	Possible visual observation and field screening if soil sampling performed	Sudan IV field test kit	1.5-in. Piezometer may be installed if field observations suggest product may accumulate
WRR	ROST-13	CPT/ROST (P-60 Area Delineation)	Possible visual observation and field screening if soil sampling performed	Sudan IV field test kit	1.5-in. Piezometer may be installed if field observations suggest product may accumulate
WRR	ROST-14	CPT/ROST (P-60 Area Delineation)	Possible visual observation and field screening if soil sampling performed	Sudan IV field test kit	1.5-in. Piezometer may be installed if field observations suggest product may accumulate
WRR	ROST-15	CPT/ROST (P-60 Area Delineation)	Possible visual observation and field screening if soil sampling performed	Sudan IV field test kit	1.5-in. Piezometer may be installed if field observations suggest product may accumulate
WRR	ROST-16	CPT/ROST (P-60 Area Delineation)	Possible visual observation and field screening if soil sampling performed	Sudan IV field test kit	1.5-in. Piezometer may be installed if field observations suggest product may accumulate
WRR	ROST-17	CPT/ROST (P-60 Area Delineation)	Possible visual observation and field screening if soil sampling performed	Sudan IV field test kit	1.5-in. Piezometer may be installed if field observations suggest product may accumulate
WRR	ROST-18	CPT/ROST (P-60 Area Delineation)	Possible visual observation and field screening if soil sampling performed	Sudan IV field test kit	1.5-in. Piezometer may be installed if field observations suggest product may accumulate
Village of Roxana Public Works	B-7	Monitoring Well Installation	Visual observation and field screening of soils	N/A	2-in. Monitoring well will be installed
Village of Roxana Public Works	B-8	Monitoring Well Installation	Visual observation and field screening of soils	N/A	2-in. Monitoring well will be installed
Second Street	VMP-1	Vapor Monitoring Point Installation	Visual observation and field screening of soils	N/A	4 soil vapor ports will be installed
Alley North of Third Street	VMP-2	Vapor Monitoring Point Installation	Visual observation and field screening of soils	N/A	4 soil vapor ports will be installed
Alley North of Fourth Street	VMP-3	Vapor Monitoring Point Installation	Visual observation and field screening of soils	N/A	4 soil vapor ports will be installed
Alley North of Fifth Street	VMP-4	Vapor Monitoring Point Installation	Visual observation and field screening of soils	N/A	4 soil vapor ports will be installed
Alley North Sixth Street	VMP-5	Vapor Monitoring Point Installation	Visual observation and field screening of soils	N/A	4 soil vapor ports will be installed
Alley North of Seventh Street	VMP-6	Vapor Monitoring Point Installation	Visual observation and field screening of soils	N/A	4 soil vapor ports will be installed
Seventh Street	VMP-7	Vapor Monitoring Point Installation	Visual observation and field screening of soils	N/A	4 soil vapor ports will be installed
Alley North of Eighth Street	VMP-8	Vapor Monitoring Point Installation	Visual observation and field screening of soils	N/A	4 soil vapor ports will be installed
Alley North of Eighth Street	VMP-9	Vapor Monitoring Point Installation	Visual observation and field screening of soils	N/A	4 soil vapor ports will be installed
Various	---	Monitoring Well Installation	Groundwater samples	VOCs (possible SVOCs)	Locations to be determined based on groundwater profiling results

GQS - Groundwater Quality Standard

**TABLE 5**  
**TARGET REPORTING LIMITS AND SCREENING LEVELS**  
**VOLATILE ORGANICS FOR SOIL AND GROUNDWATER**

Chemical of Concern	TACO Tier 1 Remediation Objectives				Laboratory Reporting Limit (ppm)
	Residential (Soil)			Groundwater	
	Ingestion (mg/kg)	Inhalation (mg/kg)	Soil Component of Groundwater (mg/kg)	Class I (mg/L)	
<b>VOLATILE ORGANICS (8260B)</b>					
Acetone	70,000	100,000	25	6.3	0.1
Acrolein (Propenal)	39	0.17	0.014	0.0035	0.05
Acrylonitrile	1	0.29	0.0006	0.001	0.05
Benzene	12	0.8	0.03 (0.032)	0.005	0.005
Bromobenzene	1,600	100	2.2	0.14	0.005
Bromochloromethane					0.005
Bromodichloromethane	10	3,000 (2,800)	0.6 (0.61)	0.0002	0.005
Bromoform	81	53 (54)	0.8 (0.77)	0.001	0.005
Bromomethane (Methyl Bromide)	110	10	0.2	0.0098	0.005
2-Butanone (MEK)	(47,000)	(13,000)	(17)	(4.2)	0.05
n-Butylbenzene					0.005
sec-Butylbenzene					0.005
tert-Butylbenzene					0.005
Carbon disulfide	7,800	720 (850)	32 (6.1)	0.7	0.05
Carbon Tetrachloride	5 (4.9)	0.3 (3.6)	0.07 (0.71)	0.005	0.005
Chlorobenzene	1,600	130 (320)	1 (1.2)	0.1	0.005
Chloroethane	<sup>c</sup>	1,500	<sup>c</sup>	NA	0.01
2-Chloroethyl vinyl ether					0.005
Chloroform	100 (21)	0.3 (0.31)	0.6 (0.44)	0.0002 (0.07)	0.005
1-Chlorohexane					0.005
Chloromethane	<sup>c</sup>	110	<sup>c</sup>	NA	0.01
2-Chlorotoluene (o-Chlorotoluene)	1,600	1,400	4	0.14	0.005
4-Chlorotoluene (p-Chlorotoluene)					0.005
Dibromochloromethane (Chlorodibromomethane)	1,600	1,300 (1,400)	0.4 (0.41)	0.14 (0.06)	0.005
1,2-Dibromo-3-Chloropropane	0.46 (0.8)	11 (0.013)	0.002 (0.0014)	0.0002	0.005
1,2-Dibromoethane	0.32	0.06 (0.04)	0.0004 (0.0003)	0.00005	0.005
Dibromomethane					0.005
1,2-Dichlorobenzene	7,000	560	17 (16)	0.6	0.005
1,3-Dichlorobenzene					0.005
1,4-Dichlorobenzene	<sup>c</sup> (120)	11,000 (3.3)	2 (2.7)	0.075	0.005
Dichlorodifluoromethane	(16,000)	(200)	(43)	(1.4)	0.005
1,1-Dichloroethane	7,800 (16,000)	1,300	23 (8)	0.7 (1.4)	0.005
1,2-Dichloroethane	7	0.4 (0.38)	0.02 (0.024)	0.005	0.005
1,1-Dichloroethene	3,900	290	0.06	0.007	0.005
cis-1,2-Dichloroethene	780	1,200 (1,300)	0.4 (0.41)	0.07	0.005
trans-1,2-Dichloroethene	1,600	3,100 (140)	0.7 (0.67)	0.1	0.005
1,2-Dichloropropane	9 (18)	15 (0.94)	0.03 (0.031)	0.005	0.005
1,3-Dichloropropane	1,600	1,000	0.83	0.14	0.005
2,2-Dichloropropane					0.005
1,1-Dichloropropene					0.005
cis-1,3-Dichloropropene					0.005
trans-1,3-Dichloropropene	6.4	1.1 (0.93)	0.004 (0.003)	0.001	0.005
Ethylbenzene	7,800	400 (350)	13 (12)	0.7	0.005
Ethyl methacrylate					0.005
Hexachlorobutadiene	78	150	2.2	0.007	0.005
2-Hexanone					0.05
Isopropylbenzene (Cumene)	(7,800)	(500)	(91)	(0.7)	0.005
p-Isopropyltoluene (p-Cymene)					0.005
Methylene Chloride	85	13	0.02	0.005	0.005
4-Methyl-2-Pentanone					0.05
Methyl tert-butyl ether (MTBE)	780	8,800 (8,400)	0.32 (0.31)	0.07	0.005
n-Propylbenzene					0.005
Styrene	16,000	1,500 (630)	4 (1.7)	0.1	0.005
1,1,1,2-Tetrachloroethane	2,300	2,100	3.2	0.21	0.005

**TABLE 5  
TARGET REPORTING LIMITS AND SCREENING LEVELS  
VOLATILE ORGANICS FOR SOIL AND GROUNDWATER**

Chemical of Concern	TACO Tier 1 Remediation Objectives				Laboratory Reporting Limit (ppm)
	Residential (Soil)			Groundwater	
	Ingestion (mg/kg)	Inhalation (mg/kg)	Soil Component of Groundwater (mg/kg)	Class I (mg/L)	
<b>VOLATILE ORGANICS (8260B)</b>					
1,1,2,2-Tetrachloroethane	310	2,000	0.22	0.42	0.005
Tetrachloroethylene	12 (1.2)	11 (2)	0.06 (0.15)	0.005	0.005
Toluene	16,000 (6,300)	650 (580)	12 (11)	1.0	0.005
1,2,3-Trichlorobenzene					0.005
1,2,4-Trichlorobenzene	780	3,200 (170)	5 (4.7)	0.07	0.005
1,1,1-Trichloroethane	<sup>c</sup>	1,200 (1,300)	2	0.2	0.005
1,1,2-Trichloroethane	310	1,800	0.02 (0.03)	0.005	0.005
Trichloroethene	58 (49)	5 (3.3)	0.06 (0.044)	0.005	0.005
Trichlorofluoromethane	(24,000)	(870)	(34)	(2.1)	0.005
1,2,3-Trichloropropane	0.092	730	0.0001	0.001	0.005
1,2,4-Trimethylbenzene	<sup>c</sup>	87	<sup>c</sup>	NA	0.005
1,3,5-Trimethylbenzene	3,900	46	10	0.35	0.005
Vinyl Acetate	78,000	1,000 (990)	170	7.0	0.05
Vinyl Chloride	0.46 (0.43)	0.28	0.01 (0.013)	0.002	
m,p-Xylenes	16,000	420 (330)	200 (170)		0.01
o-Xylenes	16,000	410 (370)	190 (170)		0.005
Xylenes (total)	16,000	320 (280)	150 (200)	10	

<sup>c</sup> No toxicity data available for this route of exposure.

NA - Not Available

Values shown in parenthesis represent proposed revisions (September 3, 2008).

**REFERENCES:**

- TACO; Appendix B Table A - Soil Remediation Objectives for Residential Properties; February 23, 2007.  
TACO Notice of Proposed Amendments; Appendix B Table A - Soil Remediation Objectives for Residential Properties; September 3, 2008.  
TACO; Appendix B Table E - Groundwater Remediation Objectives for the Groundwater Component of the Groundwater Ingestion Route; February 23, 2007.  
TACO Notice of Proposed Amendments; Appendix B Table E - Groundwater Remediation Objectives for the Groundwater Component of the Groundwater Ingestion Route; September 3, 2008.  
Soil Remediation Objectives for Residential Properties (Non-TACO Chemicals); January 6, 2009.  
Groundwater Remediation Objectives for Chemicals Not Listed in TACO; January 6, 2009.  
June 1, 2008 Revisions/Additions to Tables for Non-TACO Chemical Remediation Objectives

**TABLE 6**  
**TARGET REPORTING LIMITS AND SCREENING LEVELS**  
**SEMIVOLATILE ORGANICS FOR GROUNDWATER**

Chemical of Concern	TACO Tier 1 Remediation Objectives Groundwater Class I (mg/L)	Laboratory Reporting Limit (mg/L)
<b>SEMIVOLATILE ORGANICS (8270C)</b>		
Acenaphthene	0.42	0.005
Acenaphthylene	0.21	0.005
Aniline	0.023	0.02
Anthracene	2.1	0.005
Benzo(a)anthracene	0.00013	0.005
Benzo(b)fluoranthene	0.00018	0.005
Benzo(k)fluoranthene	0.00017 (0.0012)	0.005
Benzo(g,h,i)perylene	0.21	0.005
Benzo(a)pyrene	0.0002	0.005
Benzoic Acid	28	0.03
bis(2-Chloroethoxy) methane		0.01
Bis(2-chloroethyl) ether	0.01	0.01
Bis(2-chloroisopropyl)ether	0.28	0.01
Bis(2-ethylhexyl) phthalate	0.006	0.005
4-Bromophenyl phenyl ether		0.01
Butyl benzyl phthalate	1.4	0.005
4-Chloroaniline	0.028	0.02
4-Chloro-3-methylphenol		0.01
2-Chloronaphthalene	0.56	0.01
2-Chlorophenol	0.035	0.01
4-Chlorophenyl phenyl ether		0.01
Chrysene	0.0015 (0.012)	0.005
Dibenzo(a,h)anthracene	0.0003	0.005
Dibenzofuran	NA	0.01
3-3-Dichlorobenzidine	0.02	0.01
2,4-Dichlorophenol	0.021	0.01
Diethyl phthalate	5.6	0.005
2,4 Dimethylphenol	0.14	0.01
Dimethyl phthalate		0.005
Di-n-butyl phthalate		0.005
4,6-Dinitro-2-methylphenol	0.0007	0.01
Di-n-octyl phthalate	0.14 (0.28)	0.005
2,4-Dinitrophenol	0.014	0.01
2,4-Dinitrotoluene	0.00002	0.01
2,6-Dinitrotoluene	0.00031	0.01
Fluoranthene	0.28 (0.28)	0.005
Fluorene	0.28	0.005
Hexachlorobenzene	0.00006	0.01
Hexachlorocyclopentadiene	0.05	0.01
Hexachloroethane	0.007	0.01
Indeno(1,2,3-cd)pyrene	0.00043	0.005
Isophorone	1.4	0.01
2-Methylnaphthalene	(0.028)	0.005
2-Methylphenol (o-Cresol)	0.35	0.01
3-Methylphenol (m-Cresol)	0.35	0.01
4-Methylphenol (p-cresol)	0.035	0.01
Naphthalene	0.14	0.005
2-Nitroaniline	0.021	0.007
3-Nitroaniline	0.0021	0.01
4-Nitroaniline	0.021	0.02
Nitrobenzene	0.0035	0.01
2-Nitrophenol		0.01
4-Nitrophenol		0.01
n-Nitrosodiphenylamine	0.0032	0.01
n-Nitroso-di-n-propylamine	0.0018	0.01
Pentachlorophenol	0.001	0.01
Phenanthrene	0.21	0.005

**TABLE 6  
TARGET REPORTING LIMITS AND SCREENING LEVELS  
SEMIVOLATILE ORGANICS FOR GROUNDWATER**

Chemical of Concern	TACO Tier 1 Remediation Objectives Groundwater Class I (mg/L)	Laboratory Reporting Limit (mg/L)
<b>SEMIVOLATILE ORGANICS (8270C)</b>		
Phenol	0.1	0.01
Pyrene	0.21	0.005
Pyridine	0.007	0.01
2,4,5-Trichlorophenol	0.7	0.01
2,4,6-Trichlorophenol	0.01	0.01

NA - Not Available

Values shown in parenthesis represent proposed revisions (September 3, 2008).

**REFERENCES:**

TACO; Appendix B Table E - Groundwater Remediation Objectives for the Groundwater Component of the Groundwater Ingestion Route; February 23, 2007.

TACO Notice of Proposed Amendments; Appendix B Table E - Groundwater Remediation Objectives for the Groundwater Component of the Groundwater Ingestion Route; September 3, 2008.

Groundwater Remediation Objectives for Chemicals Not Listed in TACO; January 6, 2009.

June 1, 2008 Revisions/Additions to Tables for Non-TACO Chemical Remediation Objectives

**TABLE 7**  
**TARGET REPORTING LIMITS AND SCREENING LEVELS**  
**VOLATILE ORGANICS FOR SOIL VAPOR**

Chemical of Concern	TACO Tier 1 Remediation Objectives Residential (Soil Vapor) (mg/m <sup>3</sup> )	Laboratory Reporting Limit (ppmv)
<b>VOLATILE ORGANICS (TO-15)</b>		
Acetone	750,000	0.002
Benzene	41	0.0005
Bromodichloromethane	450,000	0.0005
Bromoform	1,800	0.0005
Bromomethane		0.0005
1,3-Butadiene		0.0005
2-Butanone (MEK)	440,000	0.0005
Carbon disulfide	81,000	0.0005
Carbon Tetrachloride	24	0.0005
Chlorobenzene	8,300	0.0005
Chloroethane		0.0005
Chloroform	12	0.0005
Chloromethane		0.002
3-Chloropropene		0.002
alpha-Chlorotoluene (benzyl chloride)		0.0005
Cyclohexane		0.0005
Dibromochloromethane	57,000	0.0005
1,2-Dibromoethane (EDB)		0.0005
1,2-Dichlorobenzene	11,000	0.0005
1,3-Dichlorobenzene		0.0005
1,4-Dichlorobenzene	317	0.0005
1,1-Dichloroethane	81,000	0.0005
1,2-Dichloroethane	10	0.0005
1,1-Dichloroethene	240	0.0005
cis-1,2-Dichloroethene	27,000	0.0005
trans-1,2-Dichloroethene	10,000	0.0005
1,2-Dichloropropane	7.2	0.0005
cis-1,3-Dichloropropene		0.0005
trans-1,3-Dichloropropene	110	0.0005
1,4-Dioxane	15	0.002
Ethanol		0.002
Ethylbenzene	59,000	0.0005
4-Ethyltoluene		0.0005
Freon 11		0.0005
Freon 113		0.0005
Freon 114		0.0005
Freon 12		0.0005
Heptane		0.0005
Hexane		0.0005
Hexachlorobutadiene		0.002
2-Hexanone		0.002
Isopropylbenzene (Cumene)	30,000	0.0005
Methylene chloride	590	0.0005
4-Methyl-2-pentanone		0.0005
MTBE	350,000	0.0005
2-Propanol		0.002
Propylbenzene		0.0005
Styrene	34,000	0.0005
1,1,2,2-Tetrachloroethane		0.0005
Tetrachloroethene	66	0.0005
Tetrahydrofuran		0.0005
Toluene	140,000	0.0005
1,2,4-Trichlorobenzene	1,600	0.002
1,1,1-Trichloroethane	770,000	0.0005
1,1,2-Trichloroethane	170,000	0.0005
Trichloroethene	180	0.0005
1,2,4-Trimethylbenzene		0.0005
1,3,5-Trimethylbenzene		0.0005
2,2,4-Trimethylpentane		0.0005
Vinyl Chloride	30	0.0005
m,p-Xylene	16,000	0.0005
o-Xylene	17,000	0.0005

**REFERENCES:**

TACO Notice of Proposed Amendments; Appendix B Table G - Indoor Inhalation Remediation Objectives for Residential Properties for the Indoor Inhalation Exposure Route; September 3, 2008.



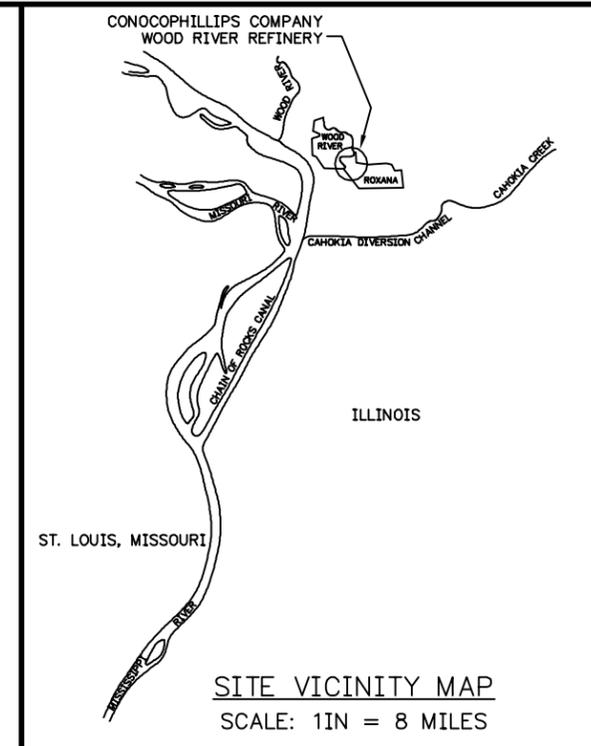
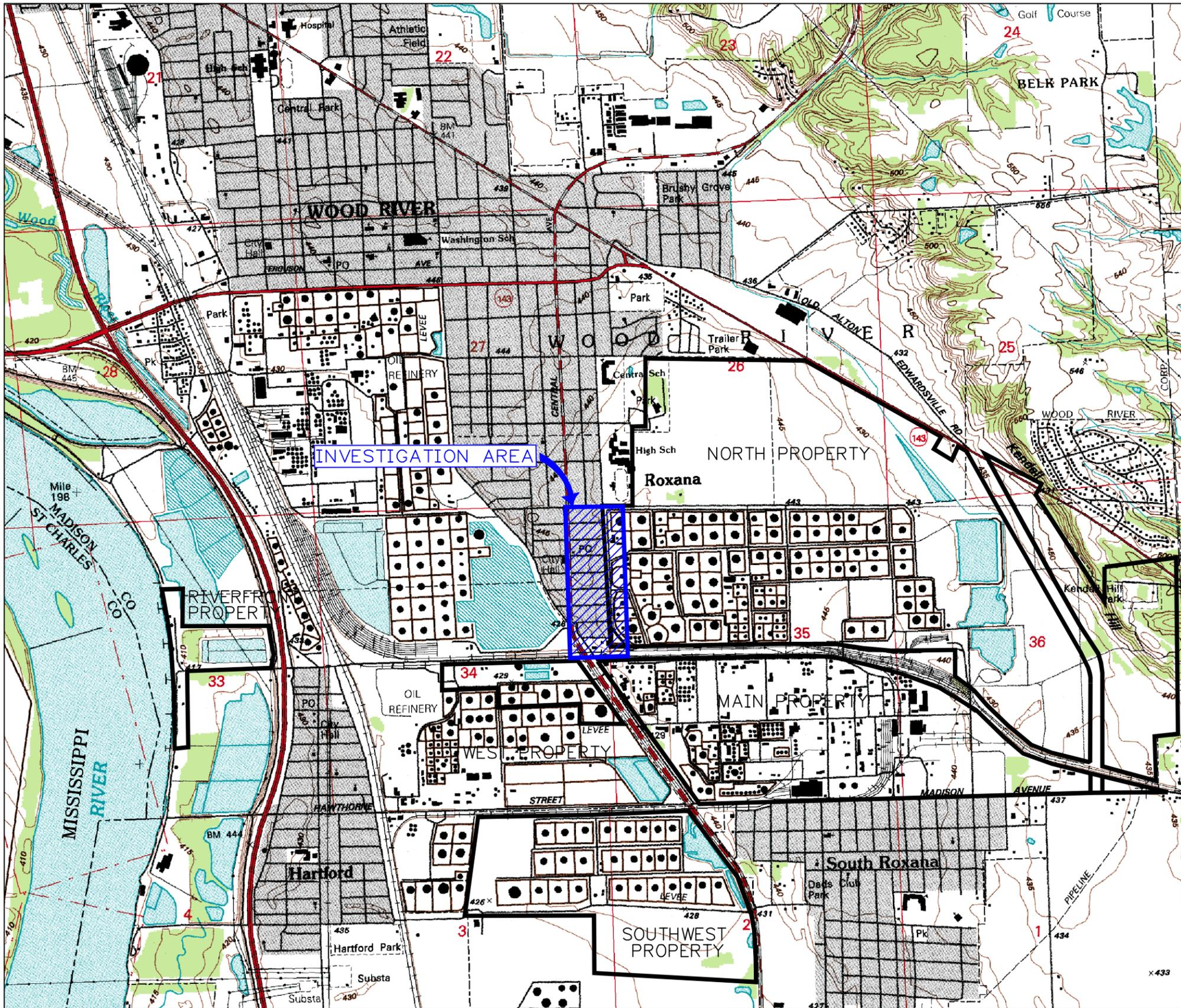

**LEGEND**

-  WOOD RIVER REFINERY PROPERTY BOUNDARY
-  INVESTIGATION AREA

SOURCE: MAP TAKEN FROM ELECTRONIC USGS DIGITAL RASTER GRAPHIC 7.5 MINUTE TOPOGRAPHIC MAP OF WOOD RIVER, ILL-MO REVISED 1994.

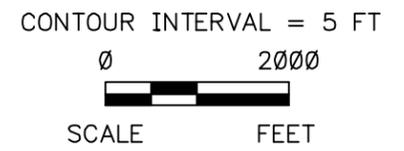

SHELL OIL PRODUCTS US DISSOLVED PHASE GROUNDWATER INVESTIGATION AND P-60 FREE PHASE PRODUCT DELINEATION ROXANA, ILLINOIS	PROJECT NO. 21561979
	
DRN. BY: djd 7/19/06 DSGN. BY: gh CHKD. BY: wmp	FIG. NO. 1

Site Location Map



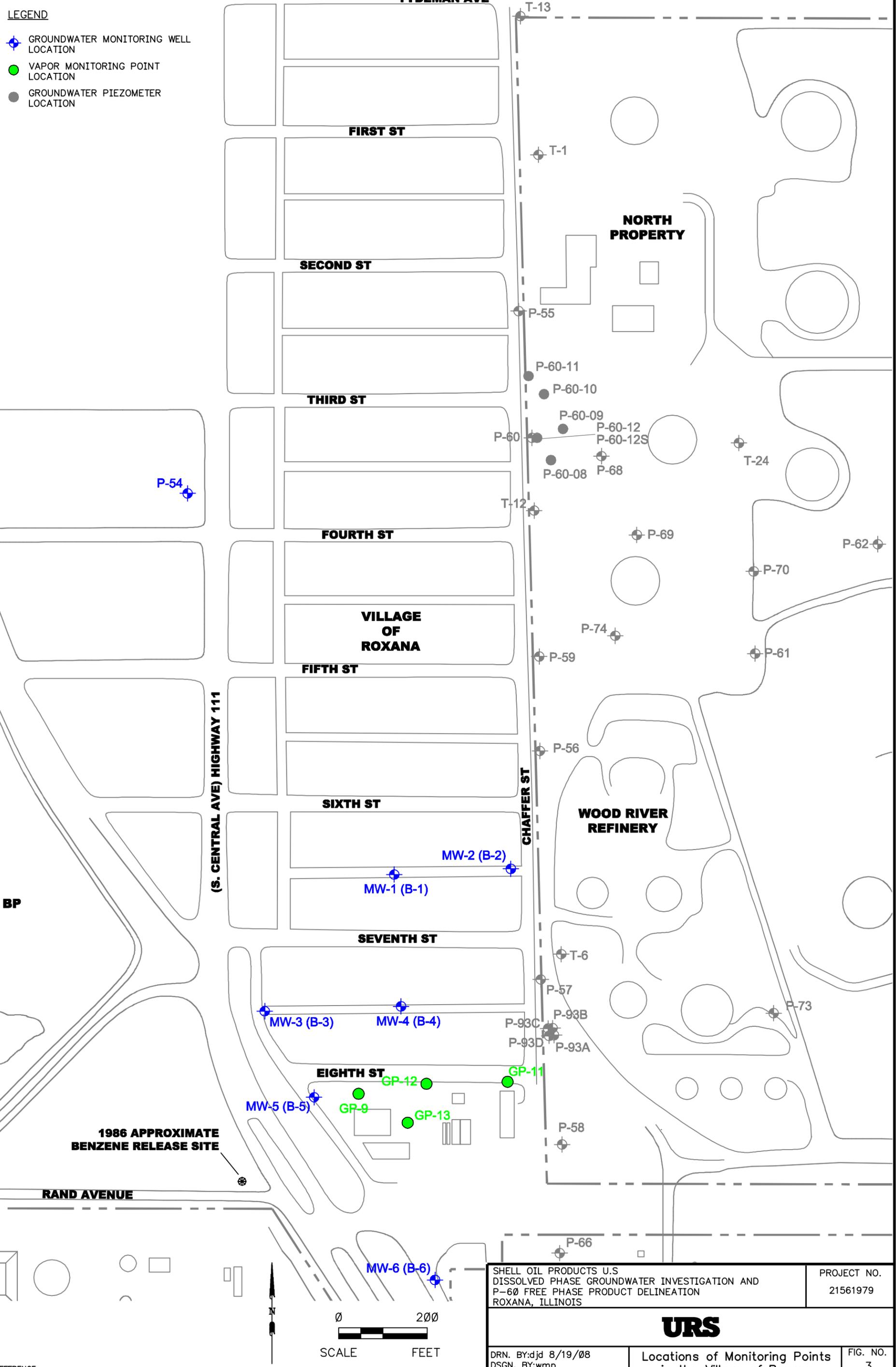

**LEGEND**

- GROUNDWATER MONITORING WELL LOCATION
- VAPOR MONITORING POINT LOCATION
- GROUNDWATER PIEZOMETER LOCATION

**1986 APPROXIMATE BENZENE RELEASE SITE**

SHELL OIL PRODUCTS U.S.  
DISSOLVED PHASE GROUNDWATER INVESTIGATION AND  
P-60 FREE PHASE PRODUCT DELINEATION  
ROXANA, ILLINOIS

PROJECT NO.  
21561979



DRN. BY:djd 8/19/08  
DSGN. BY:wmp  
CHKD. BY:b3

Locations of Monitoring Points  
in the Village of Roxana

FIG. NO.  
3

REFERENCE:  
SOPUS, WRB REFINING LLC 2008; RCRA PART B POST CLOSURE PERMIT APPLICATION; DATED JUNE 2008; PREPARED BY URS.

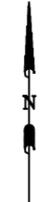

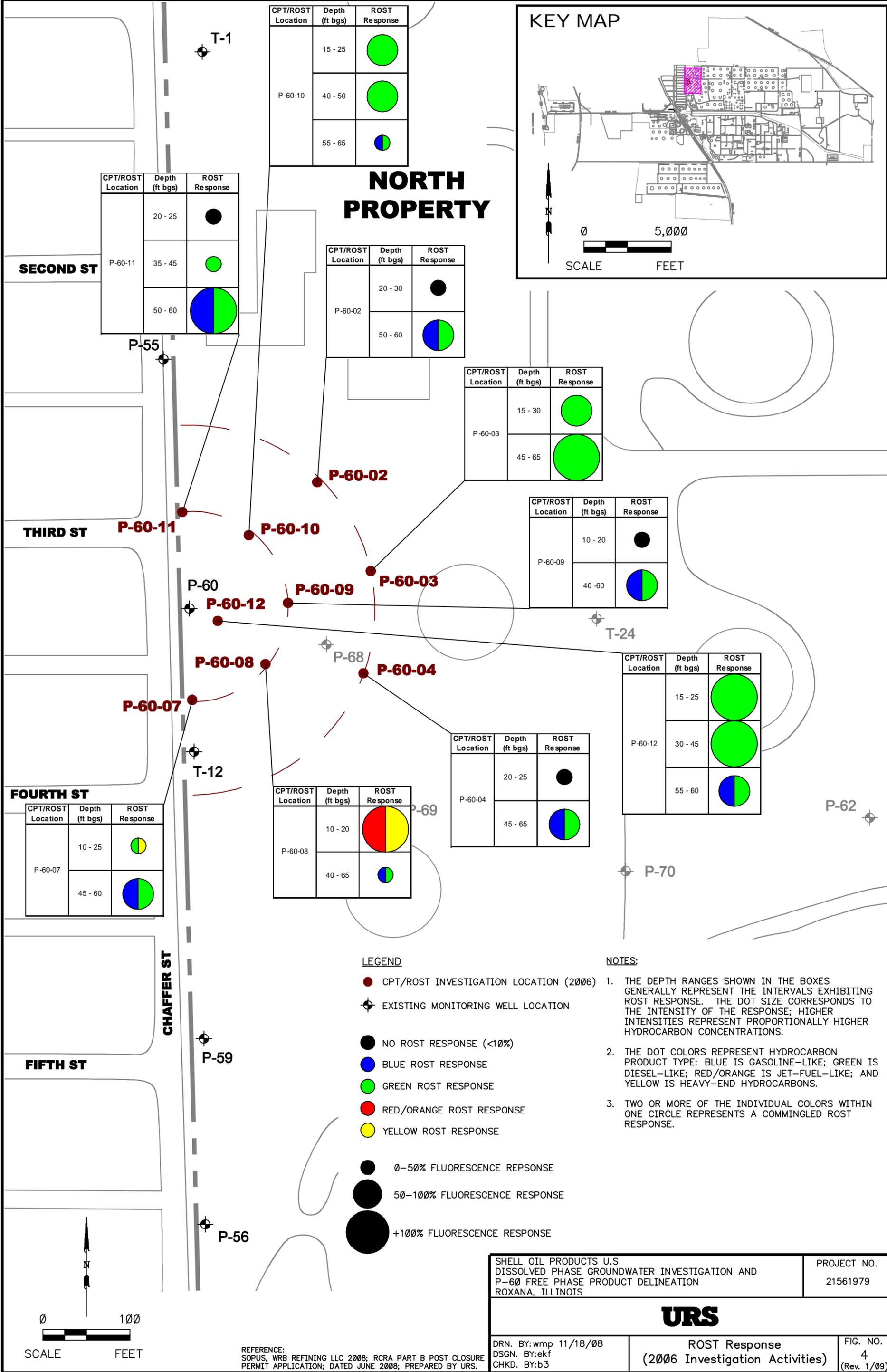

**KEY MAP**

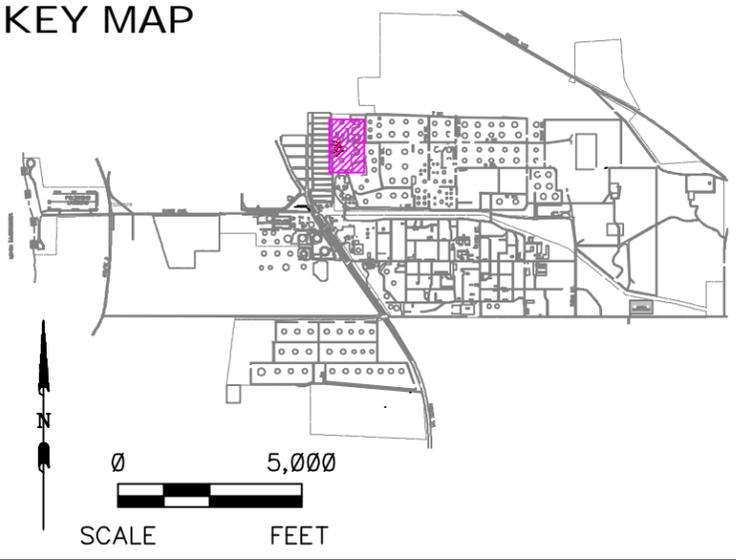

**NORTH PROPERTY**

**LEGEND**

- CPT/ROST INVESTIGATION LOCATION (2006)
- EXISTING MONITORING WELL LOCATION
- NO ROST RESPONSE (<10%)
- BLUE ROST RESPONSE
- GREEN ROST RESPONSE
- RED/ORANGE ROST RESPONSE
- YELLOW ROST RESPONSE
- 0-50% FLUORESCENCE RESPONSE
- 50-100% FLUORESCENCE RESPONSE
- +100% FLUORESCENCE RESPONSE

**NOTES:**

1. THE DEPTH RANGES SHOWN IN THE BOXES GENERALLY REPRESENT THE INTERVALS EXHIBITING ROST RESPONSE. THE DOT SIZE CORRESPONDS TO THE INTENSITY OF THE RESPONSE; HIGHER INTENSITIES REPRESENT PROPORTIONALLY HIGHER HYDROCARBON CONCENTRATIONS.
2. THE DOT COLORS REPRESENT HYDROCARBON PRODUCT TYPE: BLUE IS GASOLINE-LIKE; GREEN IS DIESEL-LIKE; RED/ORANGE IS JET-FUEL-LIKE; AND YELLOW IS HEAVY-END HYDROCARBONS.
3. TWO OR MORE OF THE INDIVIDUAL COLORS WITHIN ONE CIRCLE REPRESENTS A COMMINGLED ROST RESPONSE.

SHELL OIL PRODUCTS U.S. DISSOLVED PHASE GROUNDWATER INVESTIGATION AND P-60 FREE PHASE PRODUCT DELINEATION ROXANA, ILLINOIS	PROJECT NO. 21561979
<b>URS</b>	
DRN. BY:wmp 11/18/08 DSGN. BY:ekf CHKD. BY:b3	ROST Response (2006 Investigation Activities)
REFERENCE: SOPUS, WRB REFINING LLC 2008; RCRA PART B POST CLOSURE PERMIT APPLICATION; DATED JUNE 2008; PREPARED BY URS.	FIG. NO. 4 (Rev. 1/09)

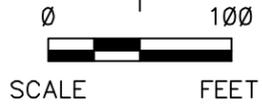

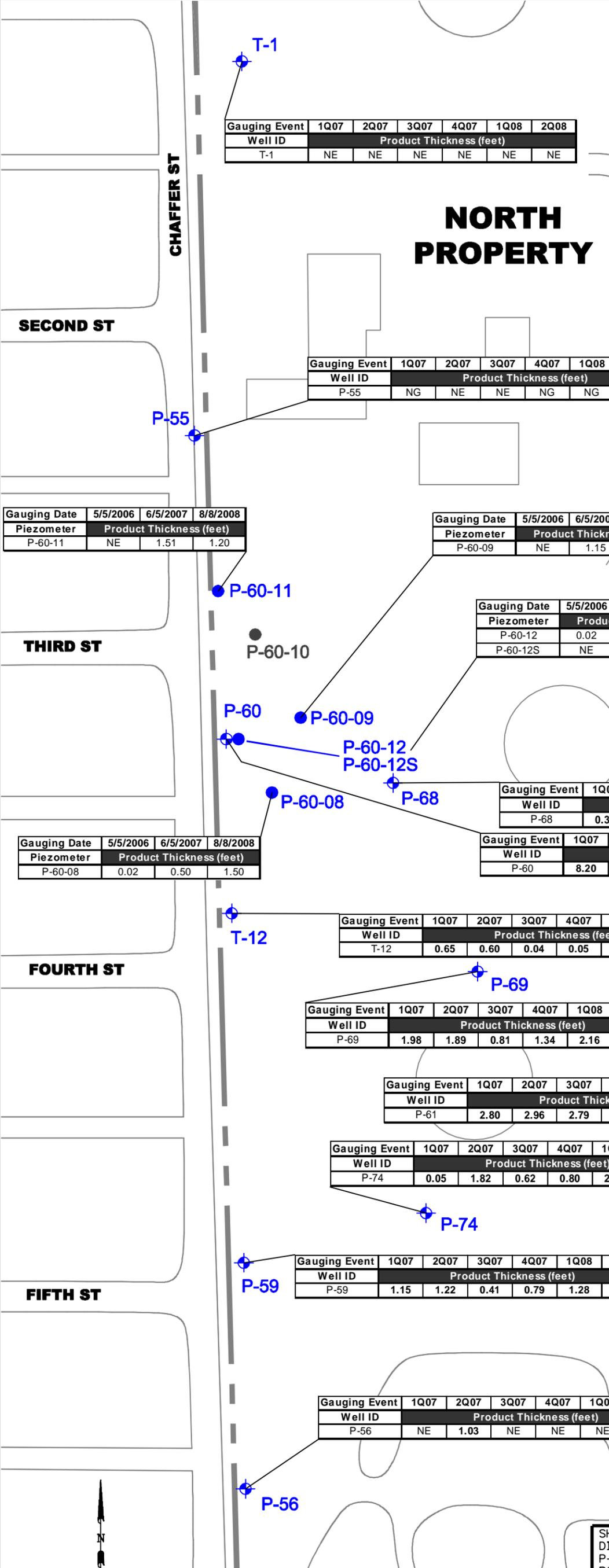
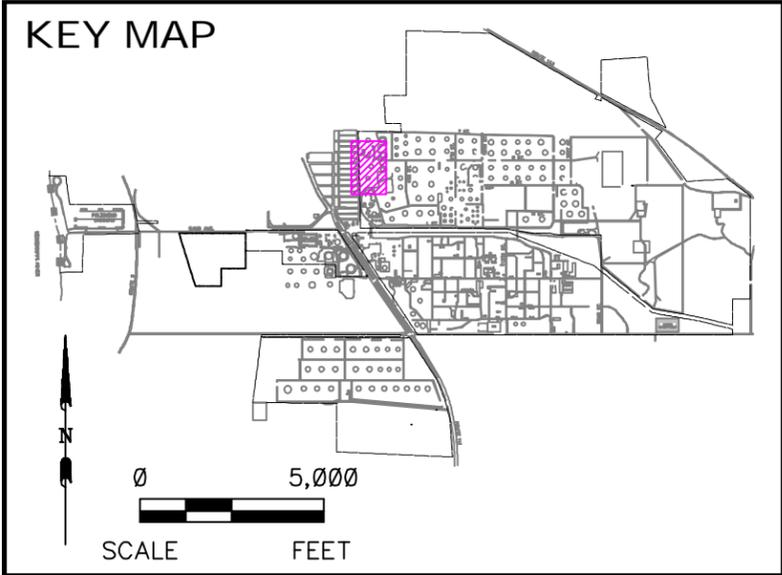

Gauging Event	1Q07	2Q07	3Q07	4Q07	1Q08	2Q08
Well ID	Product Thickness (feet)					
T-1	NE	NE	NE	NE	NE	NE

Gauging Event	1Q07	2Q07	3Q07	4Q07	1Q08	2Q08
Well ID	Product Thickness (feet)					
P-55	NG	NE	NE	NG	NG	NE

Gauging Date	5/5/2006	6/5/2007	8/8/2008
Piezometer	Product Thickness (feet)		
P-60-11	NE	1.51	1.20

Gauging Date	5/5/2006	6/5/2007	8/8/2008
Piezometer	Product Thickness (feet)		
P-60-09	NE	1.15	5.35

Gauging Date	5/5/2006	6/5/2007	8/8/2008
Piezometer	Product Thickness (feet)		
P-60-12	0.02	NE	NE
P-60-12S	NE	NE	0.71

Gauging Event	1Q07	2Q07	3Q07	4Q07	1Q08	2Q08
Well ID	Product Thickness (feet)					
T-24	2.88	2.75	2.22	2.44	3.19	2.18

Gauging Event	1Q07	2Q07	3Q07	4Q07	1Q08	2Q08
Well ID	Product Thickness (feet)					
P-68	0.35	0.15	0.22	0.23	0.20	0.78

Gauging Date	5/5/2006	6/5/2007	8/8/2008
Piezometer	Product Thickness (feet)		
P-60-08	0.02	0.50	1.50

Gauging Event	1Q07	2Q07	3Q07	4Q07	1Q08	2Q08
Well ID	Product Thickness (feet)					
P-60	8.20	7.37	8.56	7.00	NG	5.97

Gauging Event	1Q07	2Q07	3Q07	4Q07	1Q08	2Q08
Well ID	Product Thickness (feet)					
P-62	2.29	2.45	2.26	2.34	2.36	1.79

Gauging Event	1Q07	2Q07	3Q07	4Q07	1Q08	2Q08
Well ID	Product Thickness (feet)					
T-12	0.65	0.60	0.04	0.05	1.45	0.02

Gauging Event	1Q07	2Q07	3Q07	4Q07	1Q08	2Q08
Well ID	Product Thickness (feet)					
P-69	1.98	1.89	0.81	1.34	2.16	0.66

Gauging Event	1Q07	2Q07	3Q07	4Q07	1Q08	2Q08
Well ID	Product Thickness (feet)					
P-70	2.54	2.48	2.04	2.28	2.82	1.71

Gauging Event	1Q07	2Q07	3Q07	4Q07	1Q08	2Q08
Well ID	Product Thickness (feet)					
P-61	2.80	2.96	2.79	3.00	3.20	2.05

Gauging Event	1Q07	2Q07	3Q07	4Q07	1Q08	2Q08
Well ID	Product Thickness (feet)					
P-74	0.05	1.82	0.62	0.80	2.33	NG

Gauging Event	1Q07	2Q07	3Q07	4Q07	1Q08	2Q08
Well ID	Product Thickness (feet)					
P-59	1.15	1.22	0.41	0.79	1.28	0.11

Gauging Event	1Q07	2Q07	3Q07	4Q07	1Q08	2Q08
Well ID	Product Thickness (feet)					
P-56	NE	1.03	NE	NE	NE	NE

### LEGEND

- EXISTING GROUNDWATER PIEZOMETER LOCATION
- ⊕ EXISTING GROUNDWATER MONITORING WELL LOCATION

### NOTES:

1. PIEZOMETER P-60-10 HAS BEEN COVERED BY GRAVEL.
2. P-60-12 IS SCREENED APPROXIMATELY FROM 61 TO 71 FT BGS. P-60-12S IS SCREENED APPROXIMATELY FROM 14 TO 24 FEET BGS.
3. NE = NOT ENCOUNTERED  
NG = NOT GAUGED

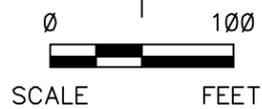

REFERENCE:  
SOPUS, WRB REFINING LLC 2008; RCRA PART B POST CLOSURE  
PERMIT APPLICATION, DATED JUNE 2008; PREPARED BY URS.

SHELL OIL PRODUCTS U.S.  
DISSOLVED PHASE GROUNDWATER INVESTIGATION AND  
P-60 FREE PHASE PRODUCT DELINEATION  
ROXANA, ILLINOIS

PROJECT NO.  
21561979

# URS

DRN. BY:wmp 11/18/08  
DSGN. BY:ekf  
CHKD. BY:b3

Product Gauging Results in the  
Vicinity of Well P-60

FIG. NO.  
5  
(Rev. 1/09)



**LEGEND**

- ▲ PROPOSED GROUNDWATER PROFILING LOCATION
- ◆ PROPOSED CPT/ROST LOCATION
- ⊕ PROPOSED GROUNDWATER MONITORING WELL LOCATION
- ⊙ PROPOSED MONITORING WELL SAMPLING LOCATION
- PROPOSED VAPOR MONITORING POINT LOCATION
- ⊞ PROPOSED SOIL BORING LOCATION (POSSIBLE GROUNDWATER SAMPLE)

**NOTES:**

1. GRAYSCALE LOCATIONS REPRESENT PREVIOUS SAMPLE LOCATIONS OR EXISTING WELLS OR VAPOR POINTS.
2. LOCATIONS MAY BE ADJUSTED BASED ON ACCESSIBILITY.

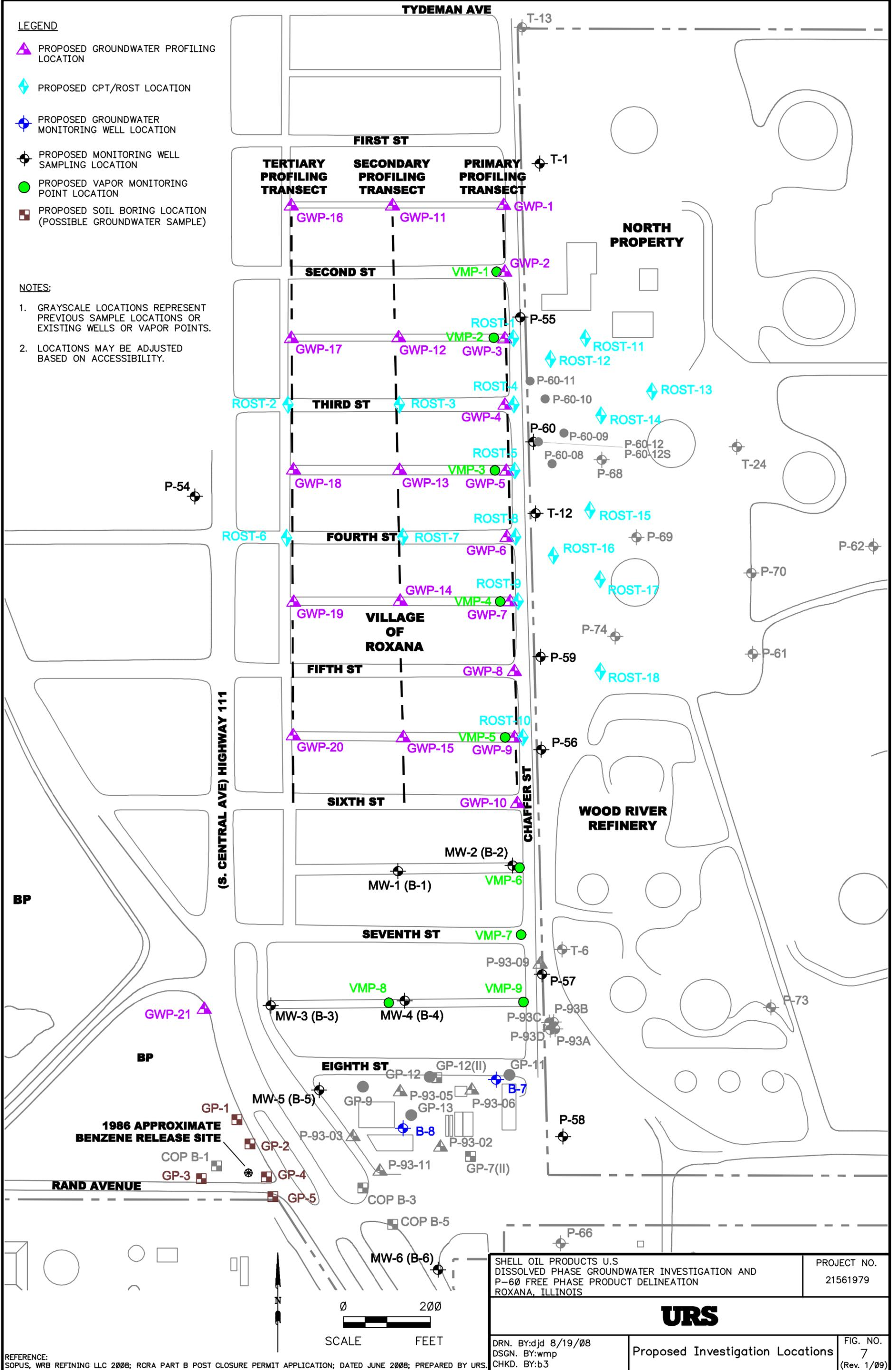

SHELL OIL PRODUCTS U.S DISSOLVED PHASE GROUNDWATER INVESTIGATION AND P-60 FREE PHASE PRODUCT DELINEATION ROXANA, ILLINOIS		PROJECT NO. 21561979
<b>URS</b>		
DRN. BY: djd 8/19/08 DSGN. BY: wmp CHKD. BY: b3	Proposed Investigation Locations	FIG. NO. 7 (Rev. 1/09)

REFERENCE:  
SOPUS, WRB REFINING LLC 2008; RCRA PART B POST CLOSURE PERMIT APPLICATION; DATED JUNE 2008; PREPARED BY URS.

CPT Logs, ROST Fluorescence Plots, Soil Boring Logs, and  
Replacement Well Construction Diagram from  
2006 P-60 Investigation

**ATTACHMENT A**

---

**CPT LOGS**

*P-60-02*  
*P-60-03*  
*P-60-04*  
*P-60-07*  
*P-60-08*  
*P-60-09A*  
*P-60-10*  
*P-60-11*  
*P-60-12*

**ROST PLOTS**

*P-60-02*  
*P-60-03*  
*P-60-04*  
*P-60-07*  
*P-60-08*  
*P-60-09A*  
*P-60-10*  
*P-60-11*  
*P-60-11*

**BORING LOGS**

*P-60-03*  
*P-60-08*  
*P-60-09*  
*P-60-10*  
*P-60-11*  
*P-60-12S*  
*P-60-12 / P-60(II)*

**WELL CONSTRUCTION DIAGRAM FOR P-60 REPLACEMENT WELL**



fUGRO GEOSCIENCES, INC.

CPT No : P-60-02

JOB No : 0305-1830

CONE No : F7.5CKEW966

SITE : HARTFORD

CLIENT : URS CORP

OPERATOR : JB

DATE : 03-28-2006

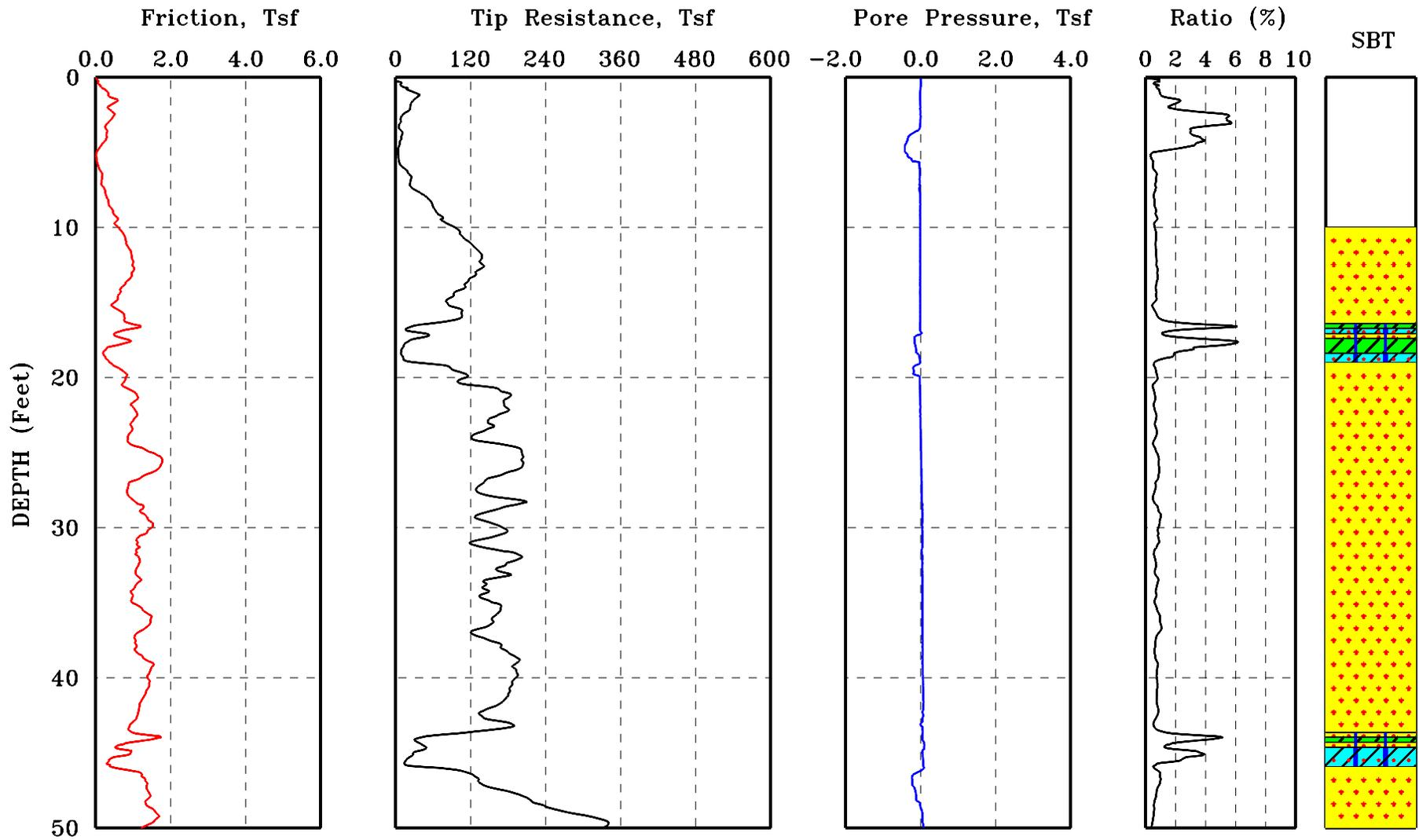

FUGRO GEOSCIENCES, INC.

CPT No : P-60-02  
JOB No : 0305-1830  
CONE No : F7.5CKEW966

SITE : HARTFORD  
CLIENT : URS CORP  
OPERATOR : JB  
DATE : 03-28-2006

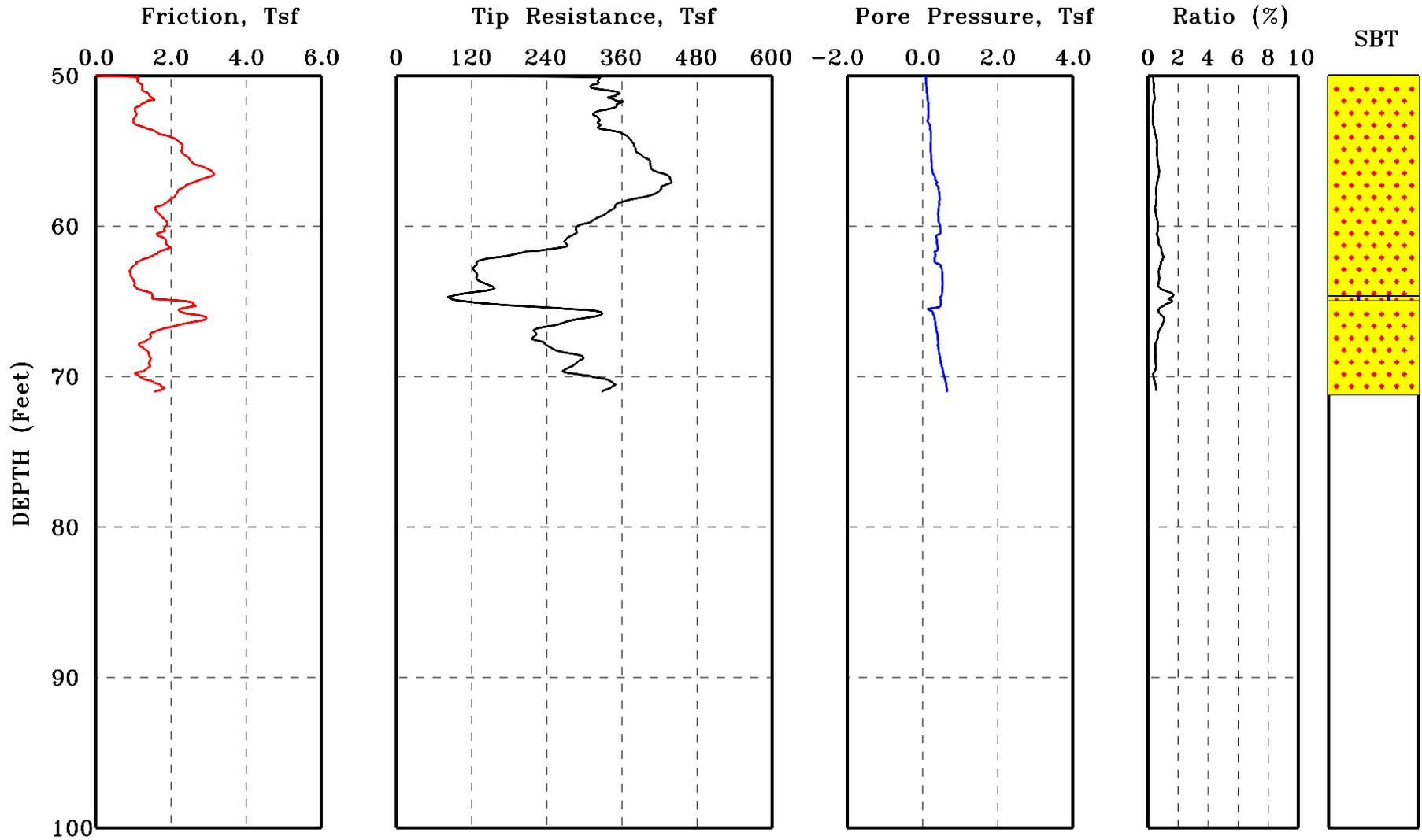

FUGRO GEOSCIENCES, INC.

CPT No : P-60-03  
JOB No : 0305-1830  
CONE No : F7.5CKEW966

SITE : HARTFORD  
CLIENT : URS CORP  
OPERATOR : JB  
DATE : 03-29-2006

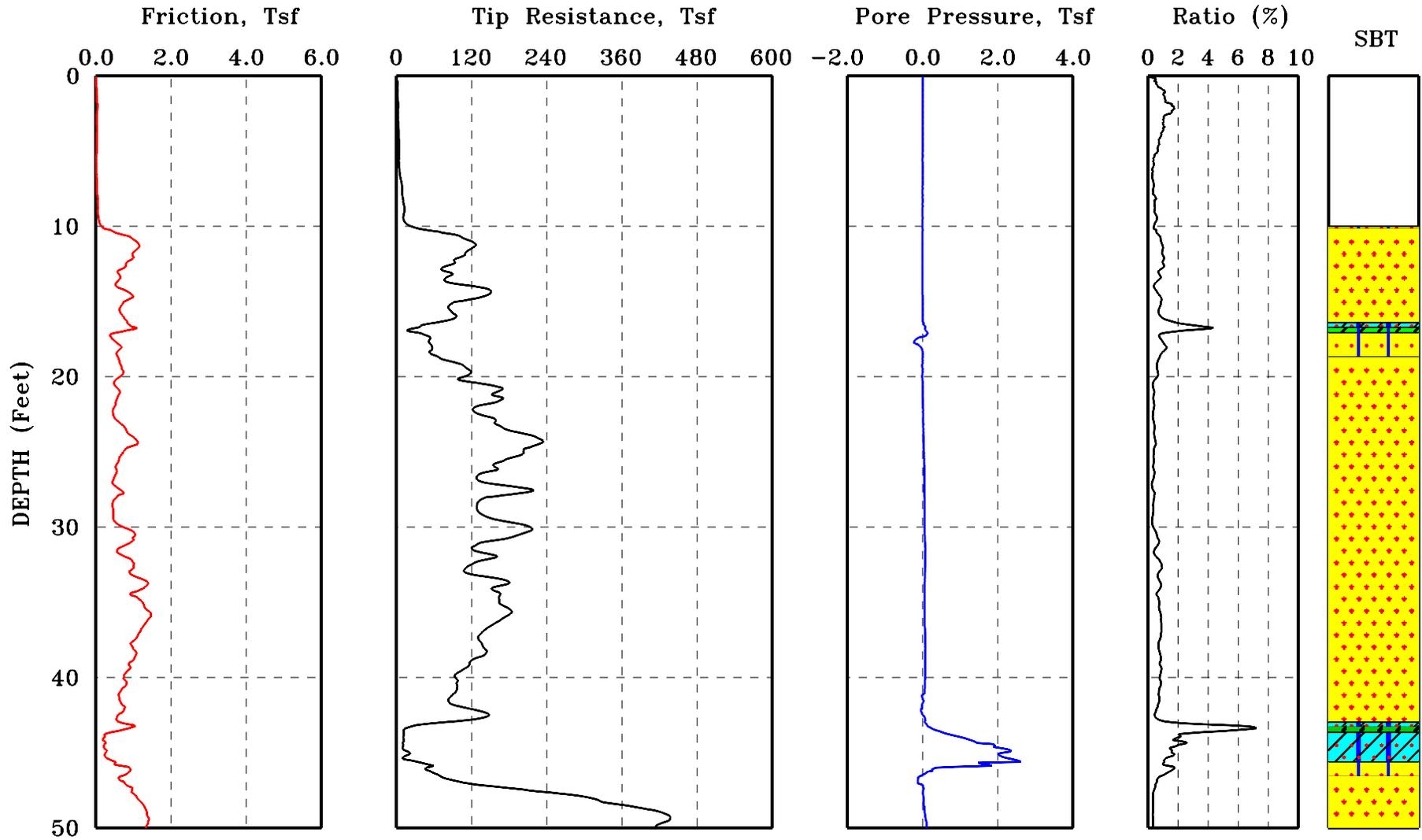

FUGRO GEOSCIENCES, INC.

CPT No : P-60-03  
JOB No : 0305-1830  
CONE No : F7.5CKEW966

SITE : HARTFORD  
CLIENT : URS CORP  
OPERATOR : JB  
DATE : 03-29-2006

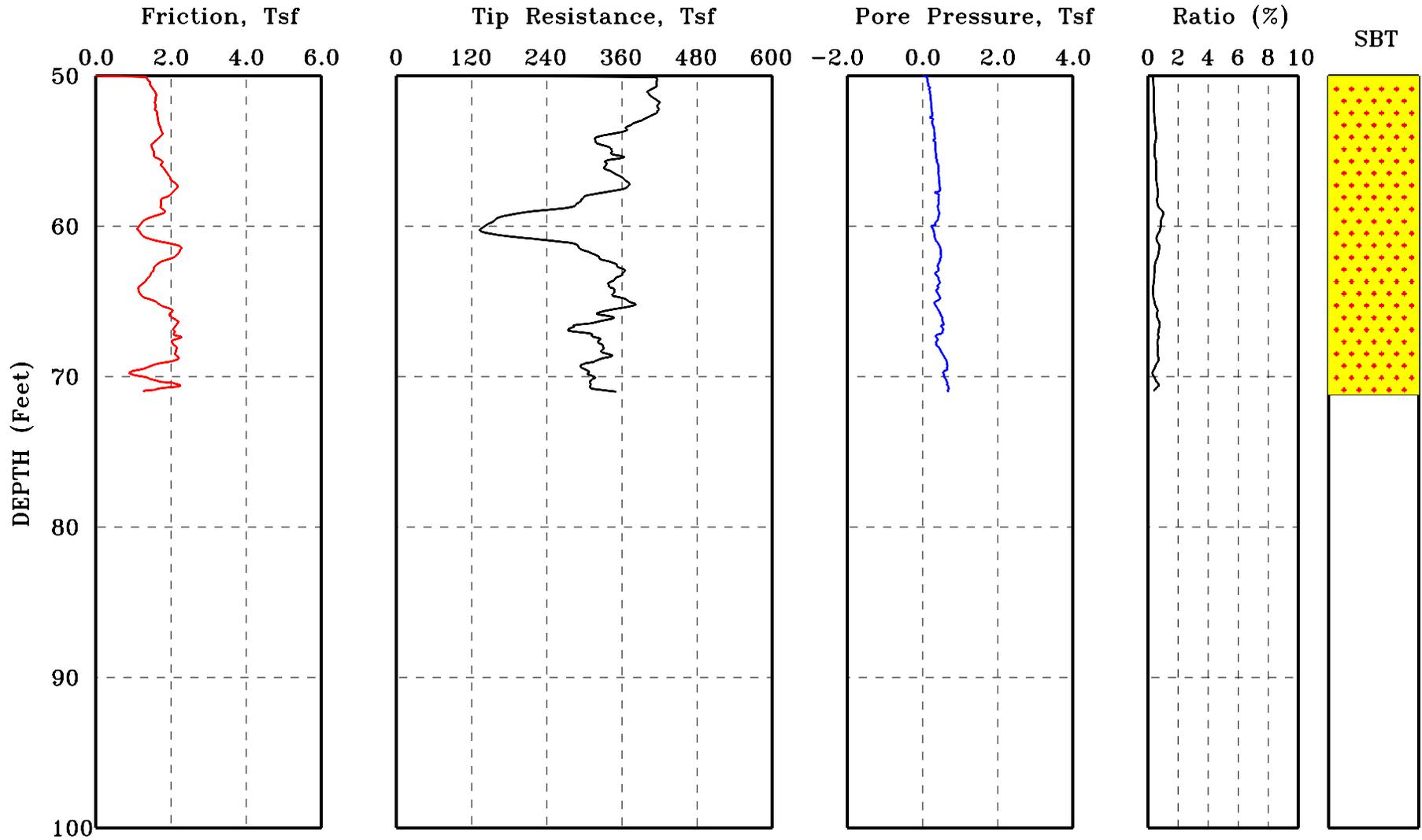

FUGRO GEOSCIENCES, INC.

CPT No : P-60-04  
JOB No : 0305-1830  
CONE No : F7.5CKEW966

SITE : HARTFORD  
CLIENT : URS CORP  
OPERATOR : JB  
DATE : 03-29-2006

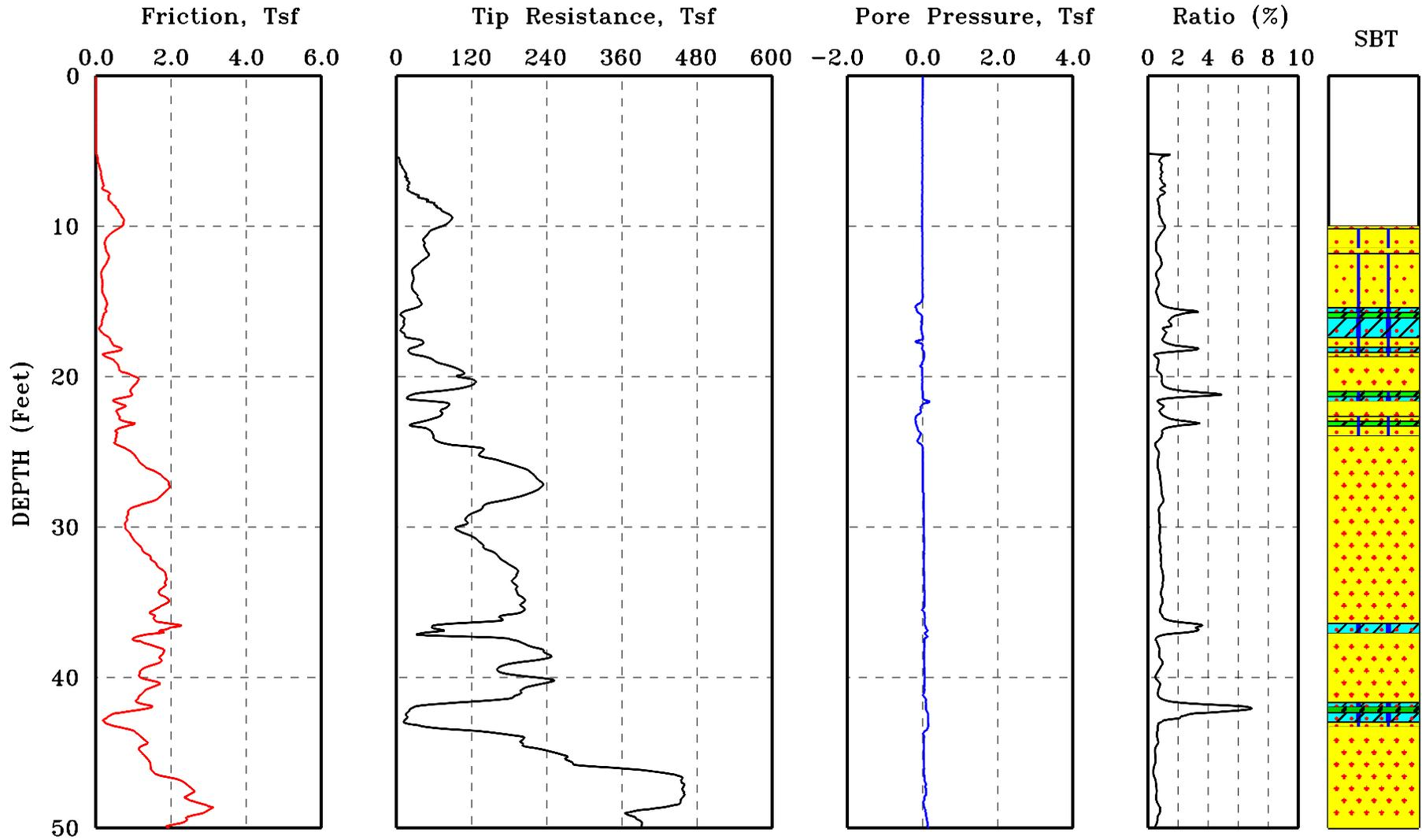

FUGRO GEOSCIENCES, INC.

CPT No : P-60-07  
JOB No : 0305-1830  
CONE No : F7.5CKEW966

SITE : HARTFORD  
CLIENT : URS CORP  
OPERATOR : JB  
DATE : 03-29-2006

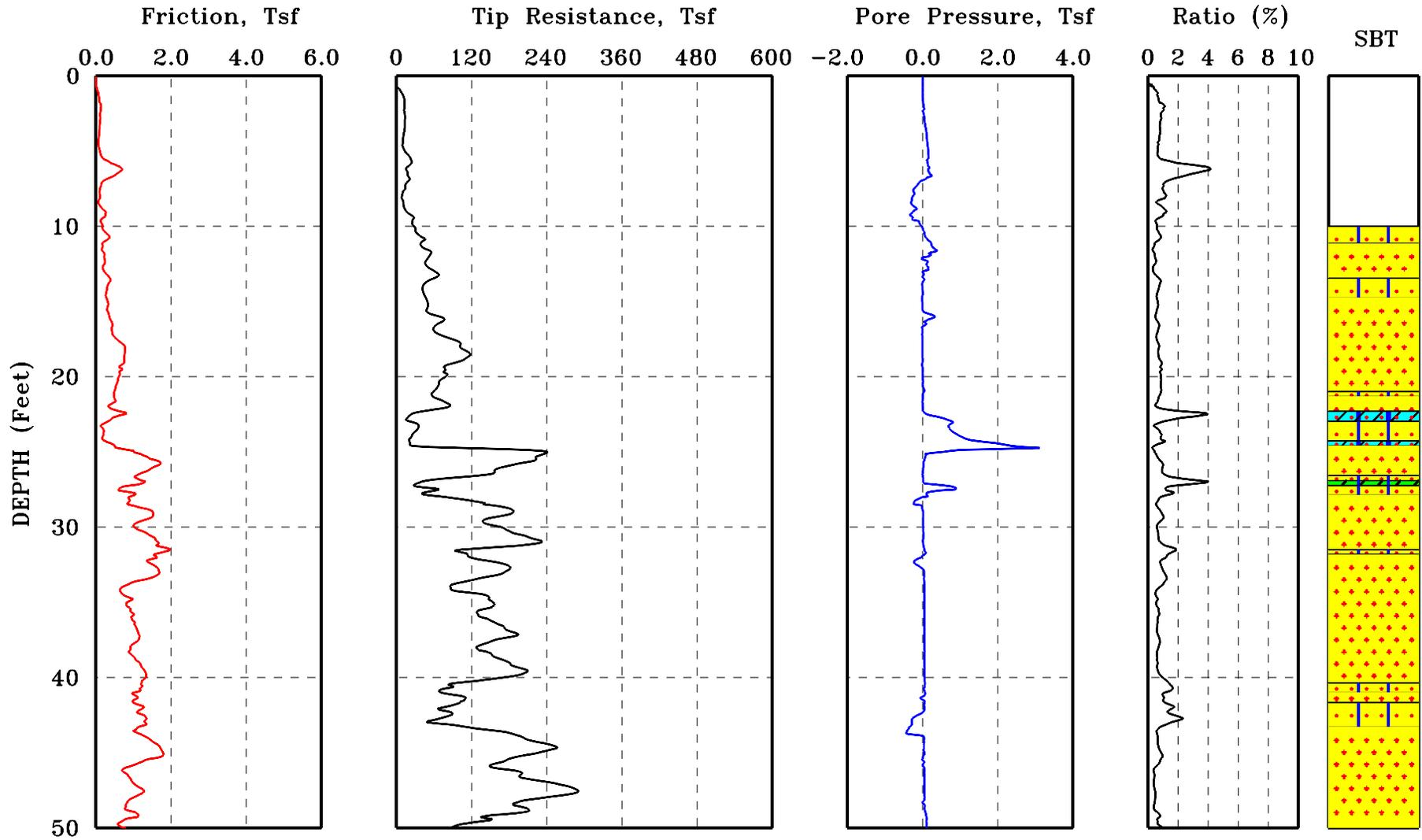

FUGRO GEOSCIENCES, INC.

CPT No : P-60-07  
JOB No : 0305-1830  
CONE No : F7.5CKEW966

SITE : HARTFORD  
CLIENT : URS CORP  
OPERATOR : JB  
DATE : 03-29-2006

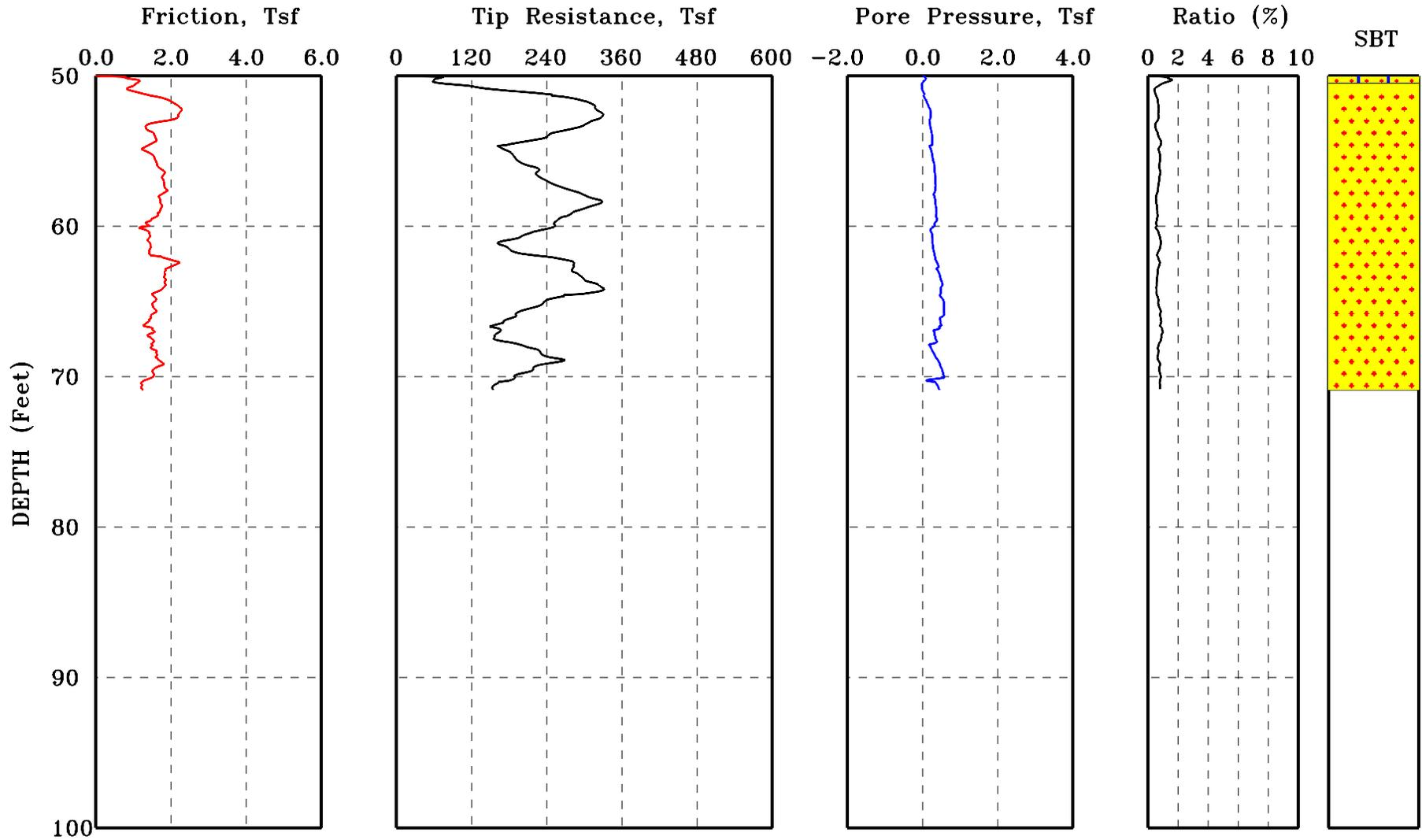

FUGRO GEOSCIENCES, INC.

CPT No : P-60-08  
JOB No : 0305-1830  
CONE No : F7.5CKEW966

SITE : HARTFORD  
CLIENT : URS CORP  
OPERATOR : JB  
DATE : 03-29-2006

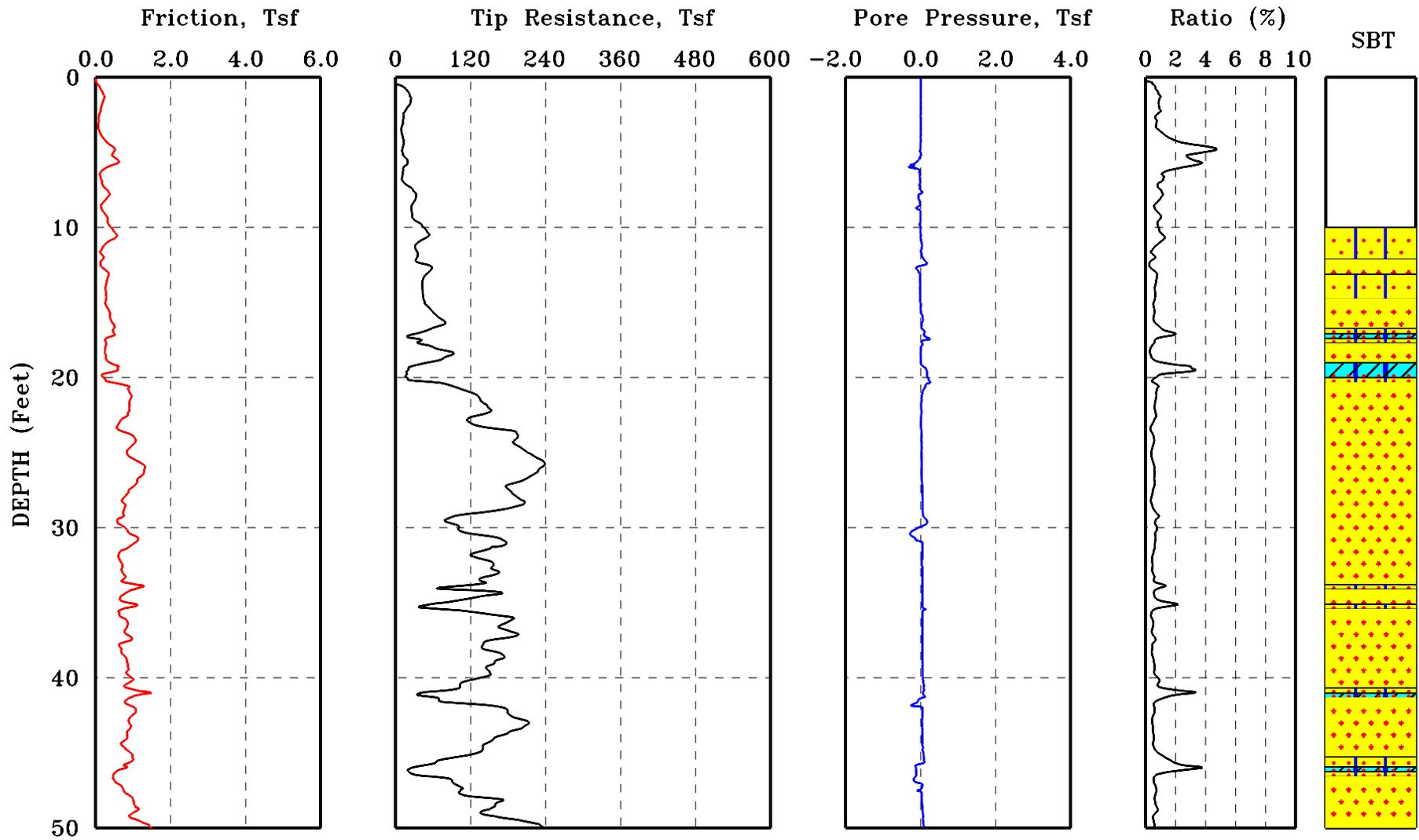

**FUGRO GEOSCIENCES, INC.**

CPT No : P-60-08  
 JOB No : 0305-1830  
 CONE No : F7.5CKEW966

SITE : HARTFORD  
 CLIENT : URS CORP  
 OPERATOR : JB  
 DATE : 03-29-2006

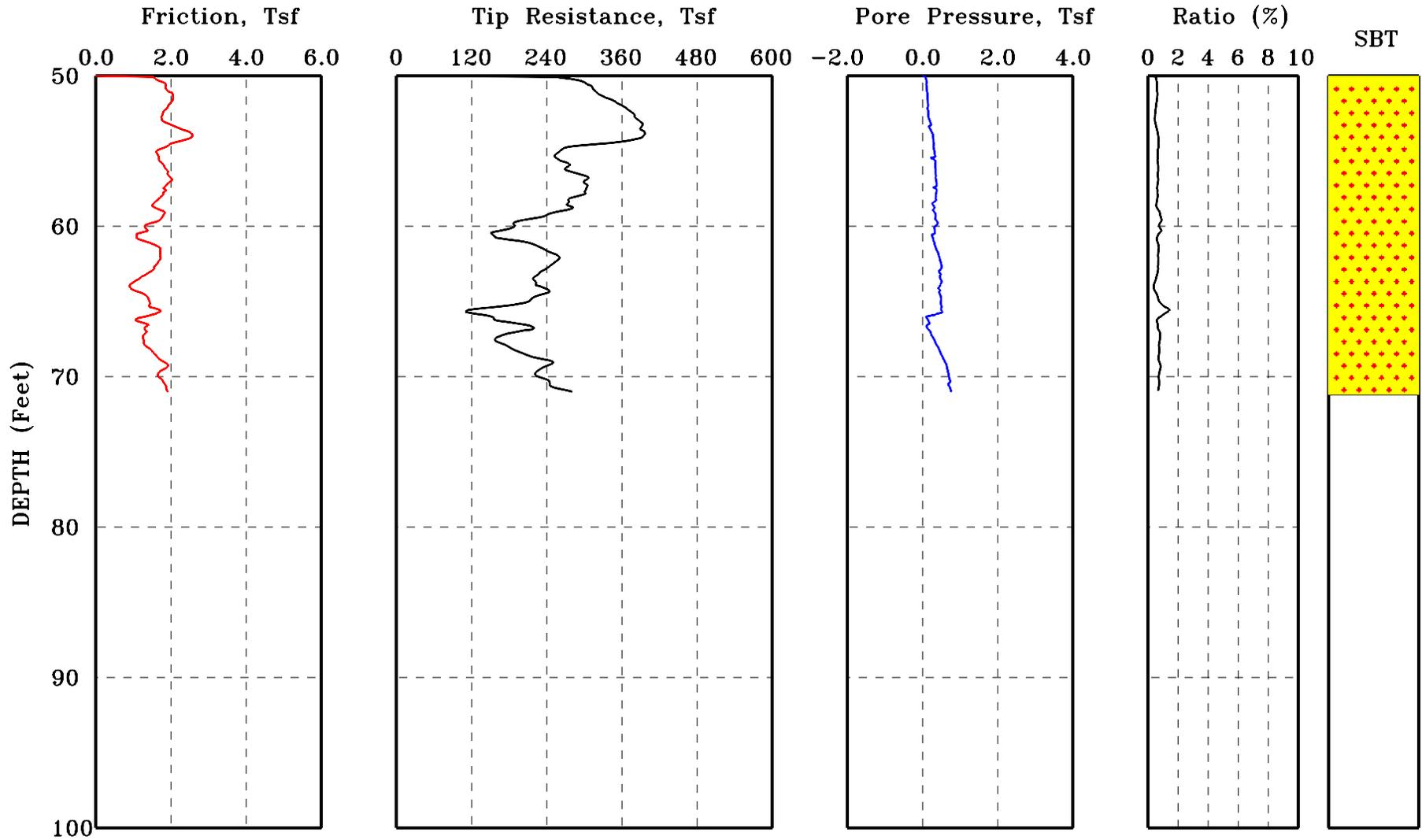

FUGRO GEOSCIENCES, INC.

CPT No : P-60-09A  
JOB No : 0305-1830  
CONE No : F7.5CKEW966

SITE : HARTFORD  
CLIENT : URS CORP  
OPERATOR : GJ  
DATE : 03-29-2006

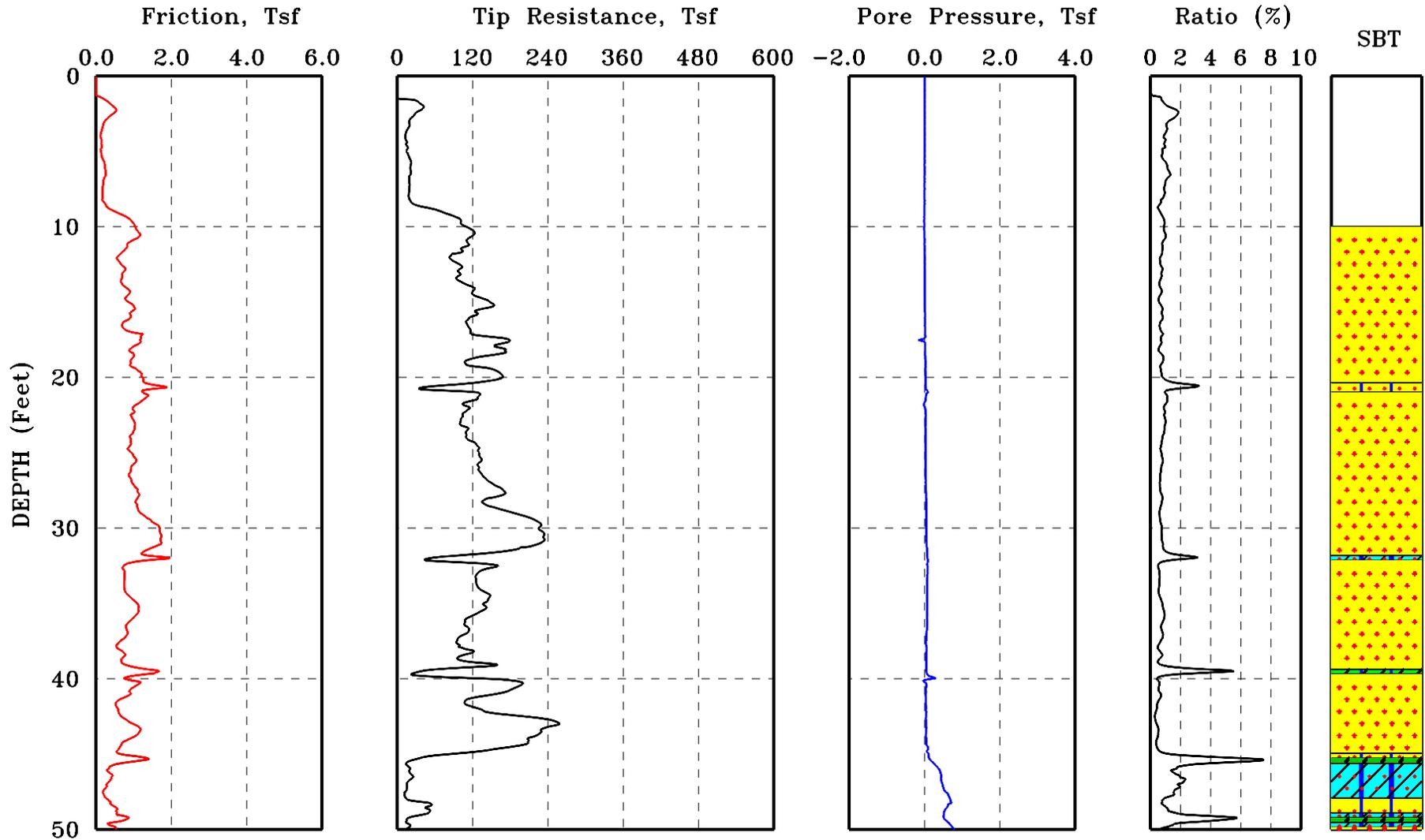

FUGRO GEOSCIENCES, INC.

CPT No : P-60-09A  
JOB No : 0305-1830  
CONE No : F7.5CKEW966

SITE : HARTFORD  
CLIENT : URS CORP  
OPERATOR : GJ  
DATE : 03-29-2006

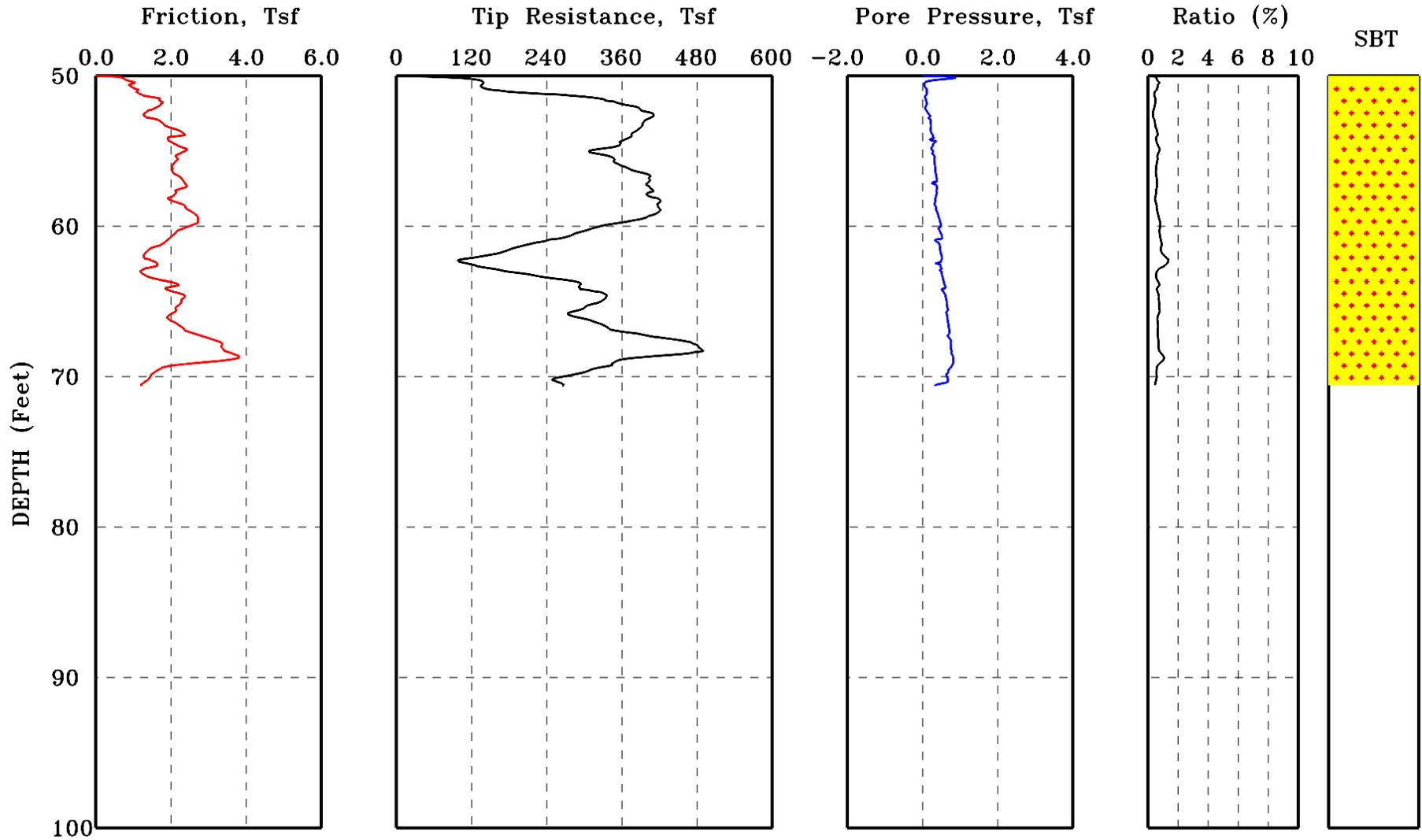

FUGRO GEOSCIENCES, INC.

CPT No : P-60-10  
JOB No : 0305-1830  
CONE No : F7.5CKEW966

SITE : HARTFORD  
CLIENT : URS CORP  
OPERATOR : JB  
DATE : 03-28-2006

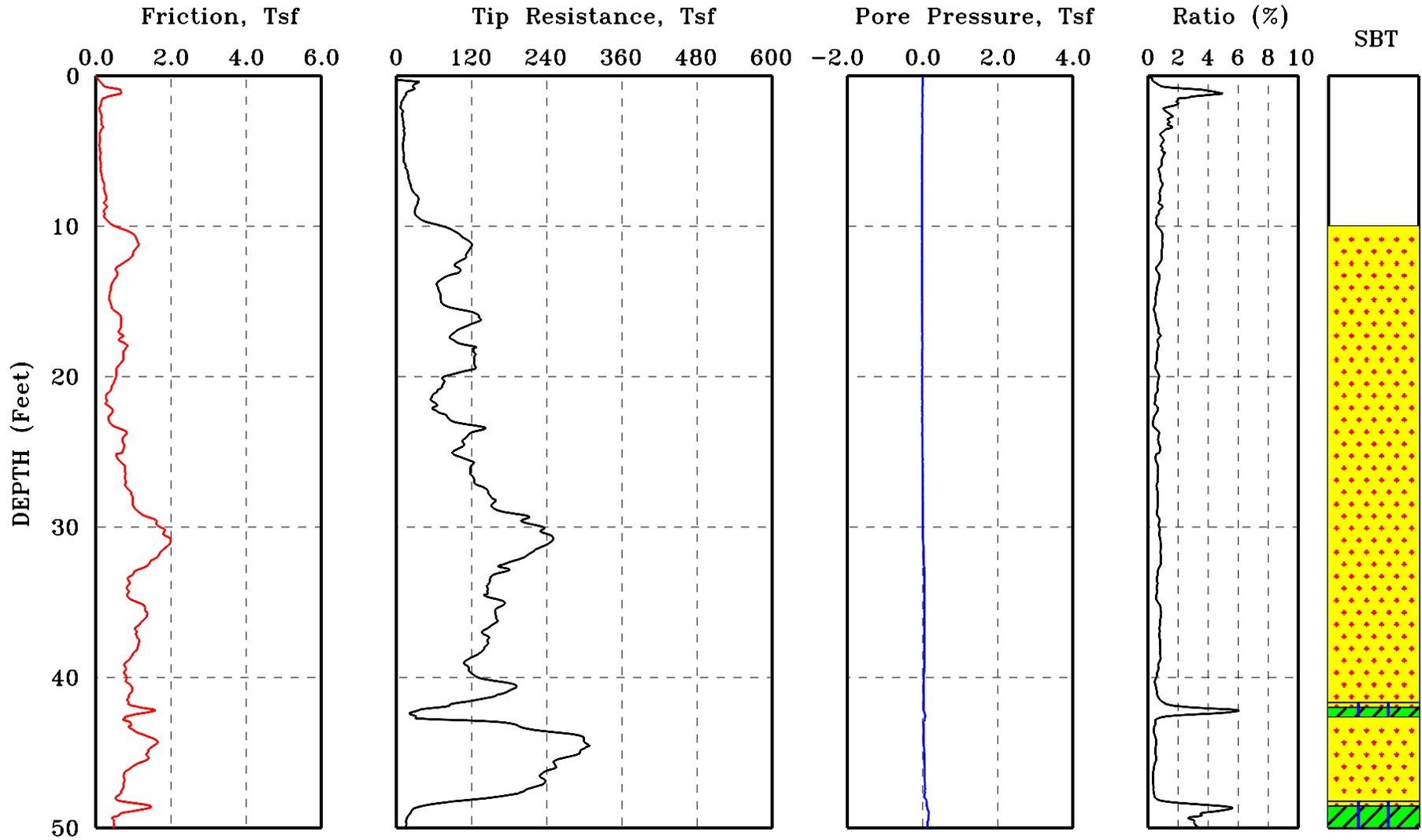

FUGRO GEOSCIENCES, INC.

CPT No : P-60-10  
JOB No : 0305-1830  
CONE No : F7.5CKEW966

SITE : HARTFORD  
CLIENT : URS CORP  
OPERATOR : JB  
DATE : 03-28-2006

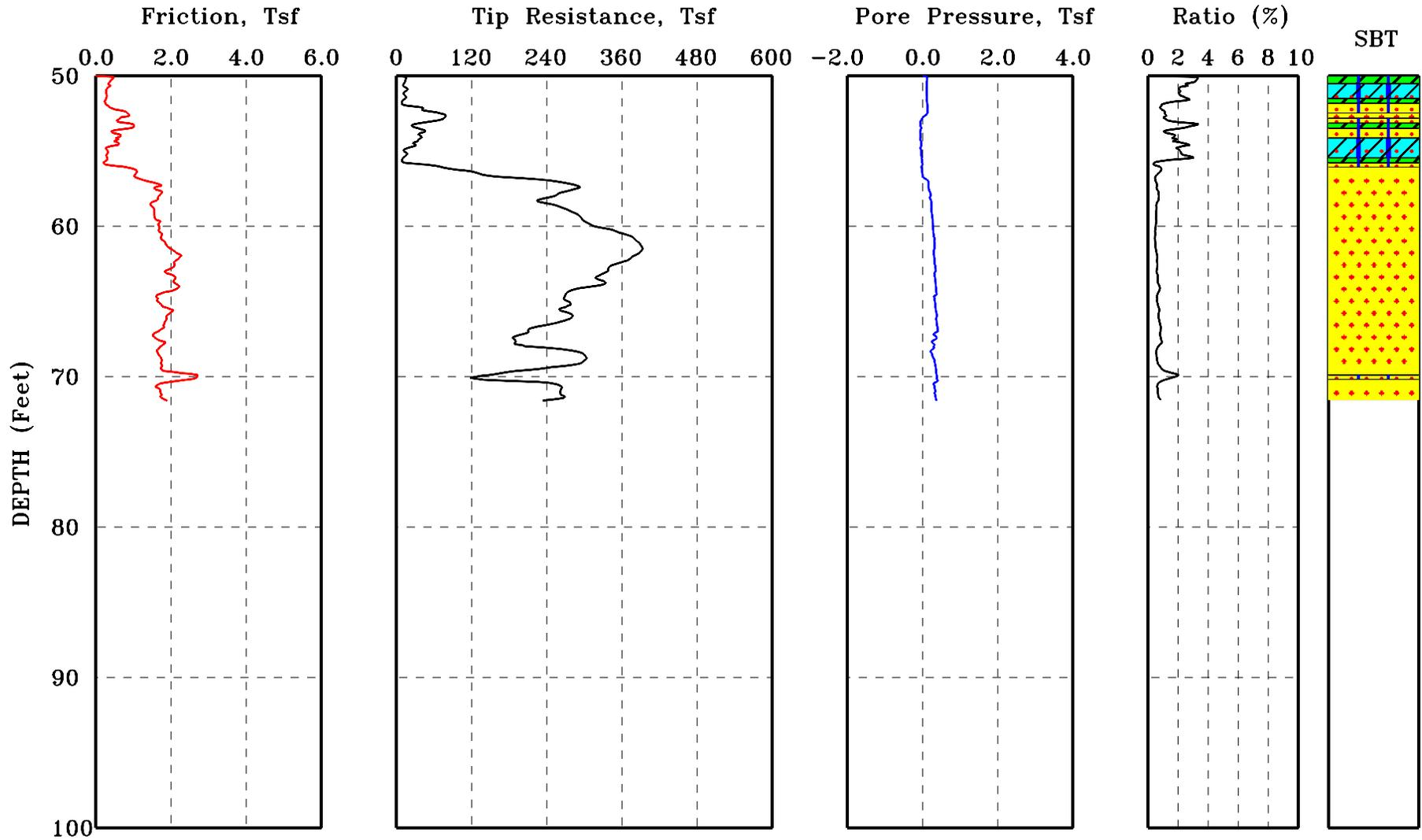

FUGRO GEOSCIENCES, INC.

CPT No : P-60-11  
JOB No : 0305-1830  
CONE No : F7.5CKEW966

SITE : HARTFORD  
CLIENT : URS CORP  
OPERATOR : JB  
DATE : 03-28-2006

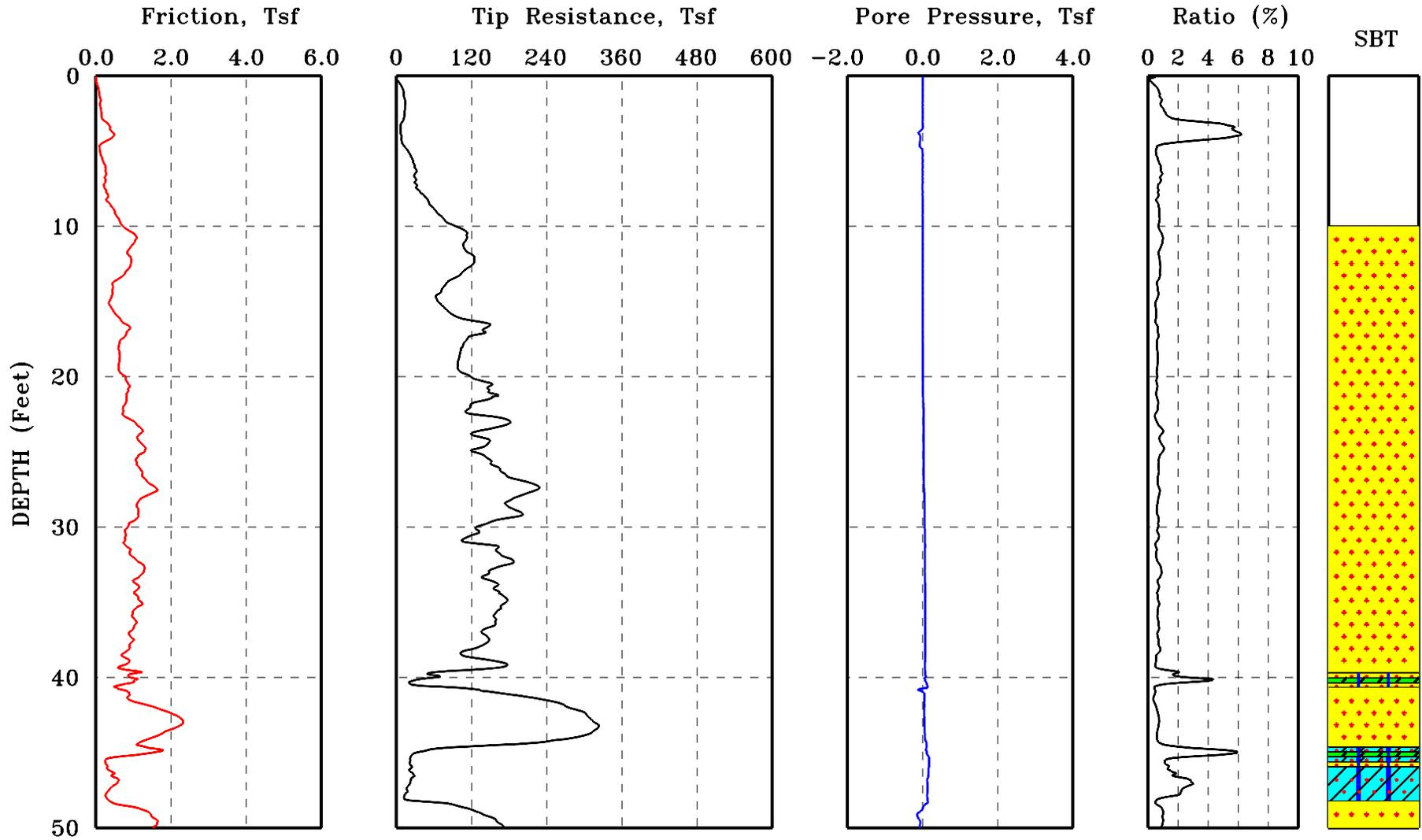

FUGRO GEOSCIENCES, INC.

CPT No : P-60-11  
JOB No : 0305-1830  
CONE No : F7.5CKEW966

SITE : HARTFORD  
CLIENT : URS CORP  
OPERATOR : JB  
DATE : 03-28-2006

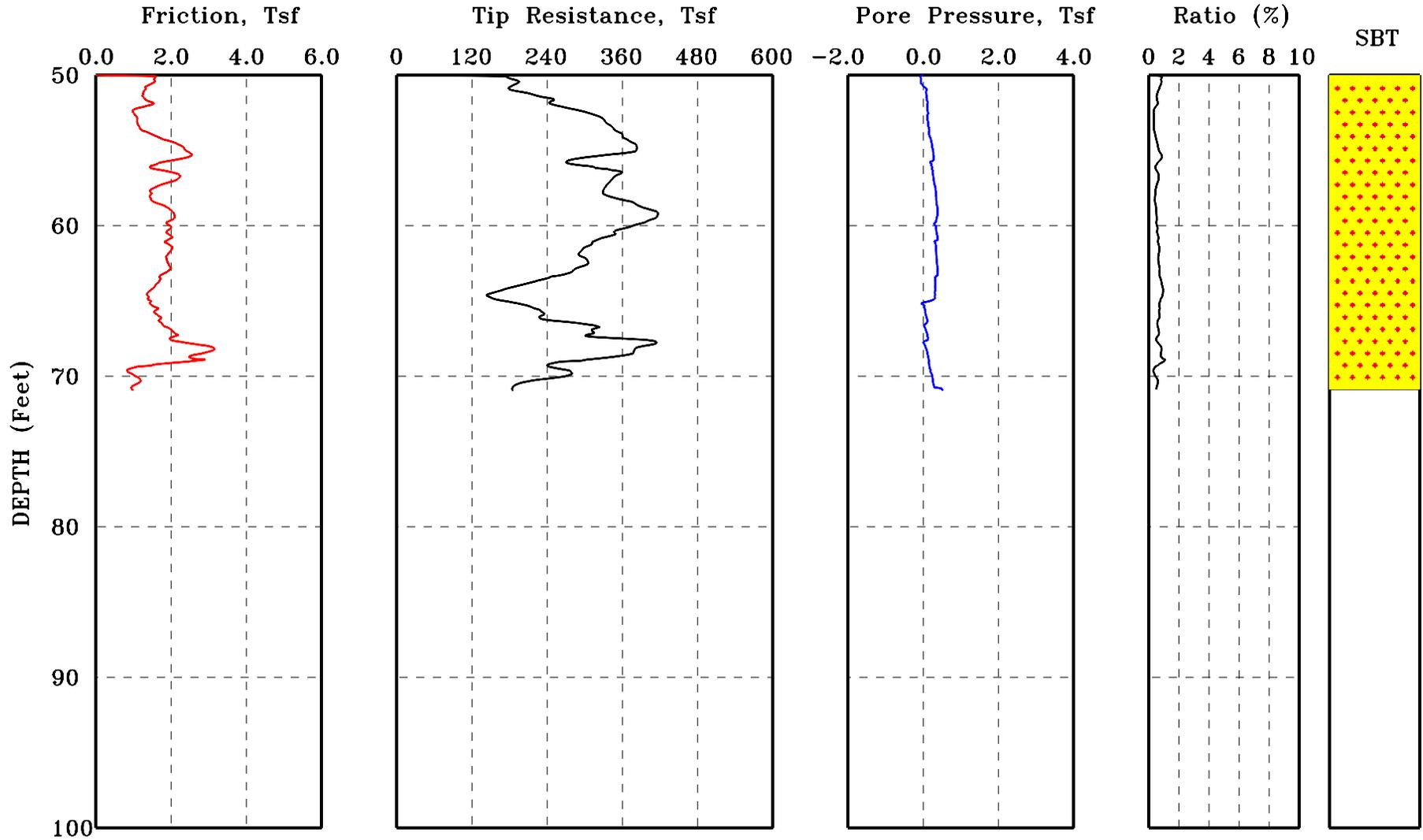

FUGRO GEOSCIENCES, INC.

CPT No : P-60-12  
 JOB No : 0305-1830  
 CONE No : F7.5CKEW966

SITE : HARTFORD  
 CLIENT : URS CORP  
 OPERATOR : JB  
 DATE : 03-28-2006

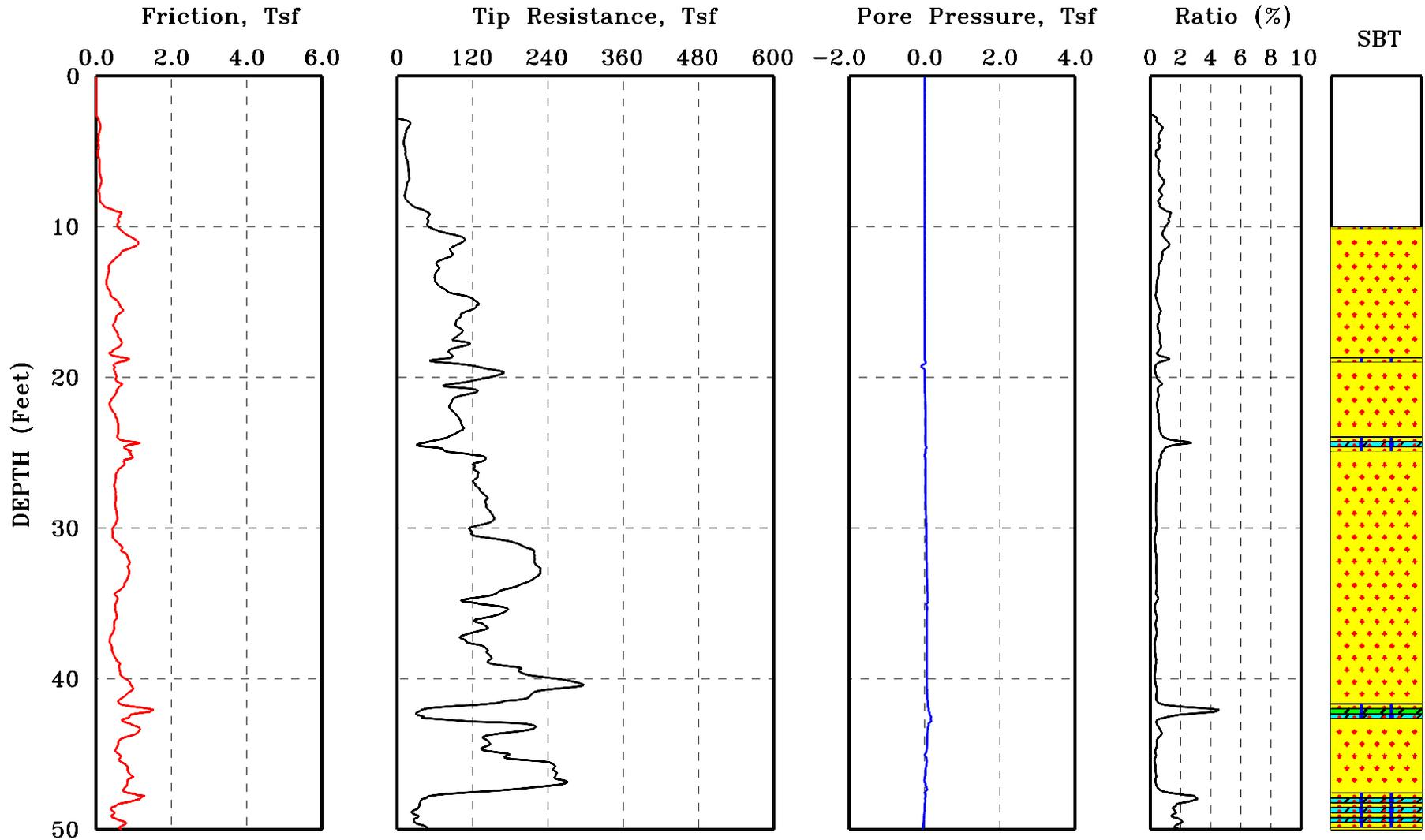

FUGRO GEOSCIENCES,INC.

CPT No : P-60-12  
JOB No : 0305-1830  
CONE No : F7.5CKEW966

SITE : HARTFORD  
CLIENT : URS CORP  
OPERATOR : JB  
DATE : 03-28-2006

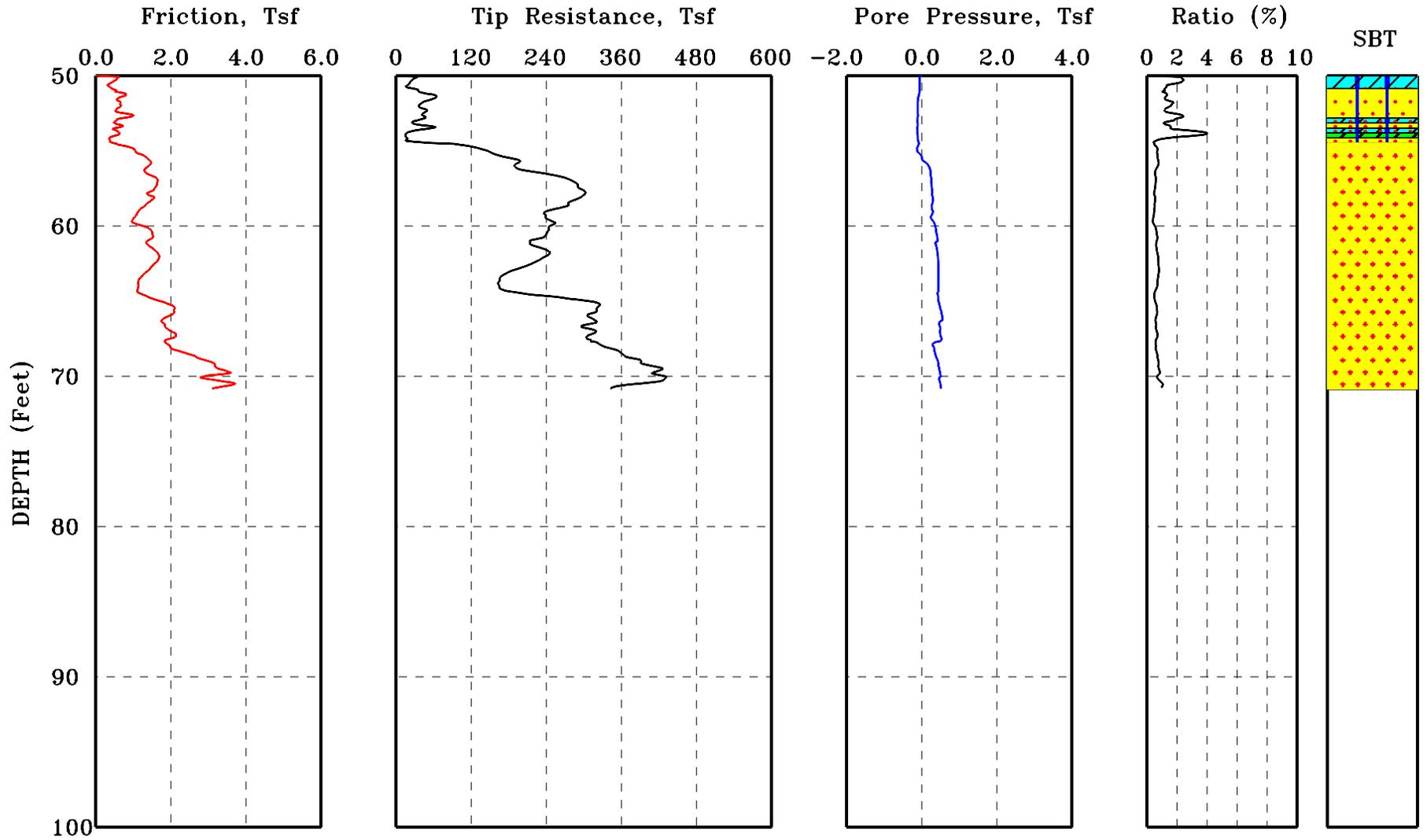

# ROST Fluorescence Response Data

Site: CONOCO PHILLIPS HARTFORD,IL.  
Client: URS  
Date/Time: 3/28/2006 @ 11:26:59 AM  
ROST Unit: 5

Operator: GLENN  
Fugro Job #: 0305-1830  
Max fluorescence: 72.34% @ 51.76 ft  
Final depth BGS: 70.09 ft

## P-60-02

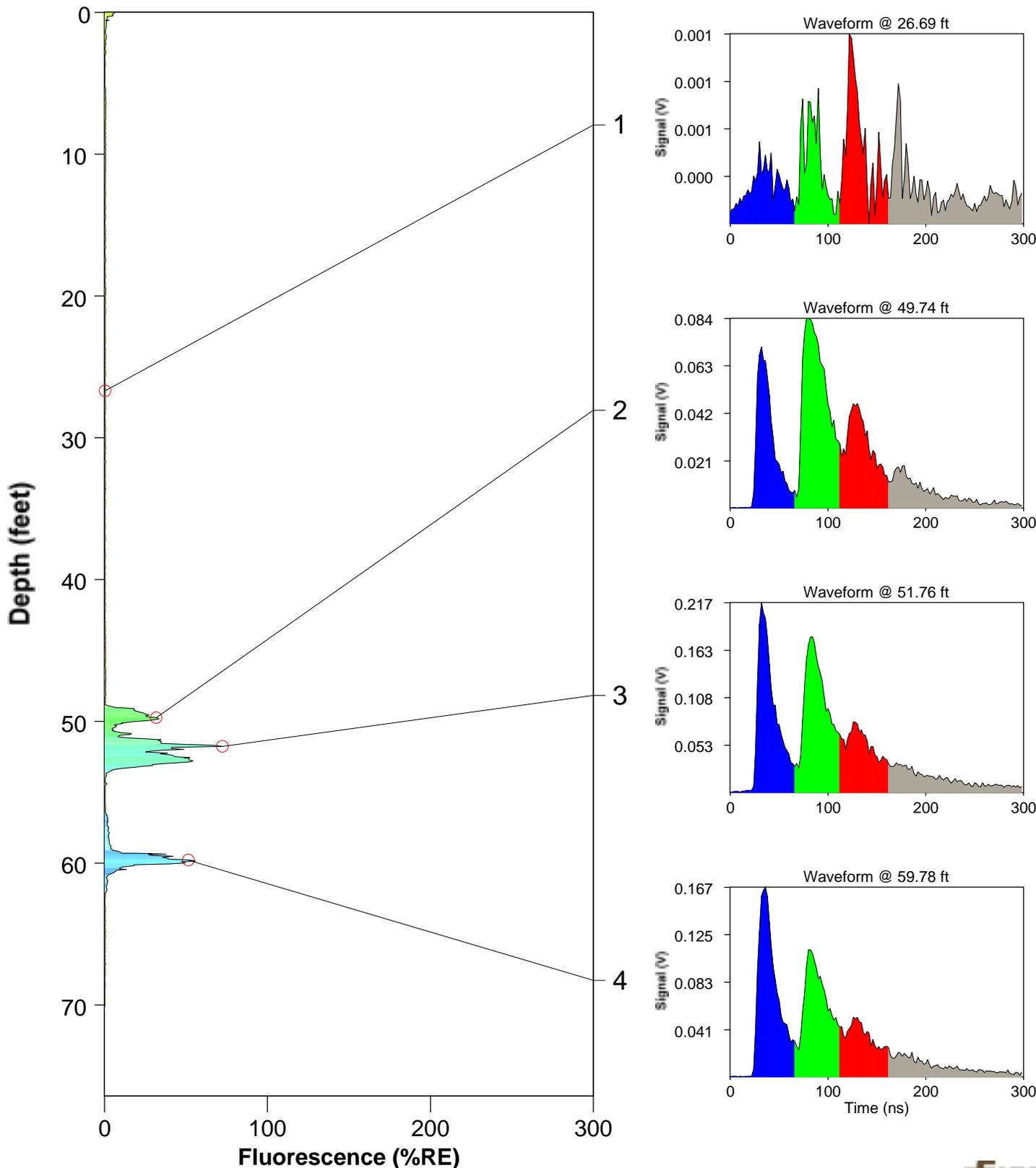

ROST Fluorescence Response Data

Site: CONOCO PHILLIPS HARTFORD,IL.	Operator: GLENN
Client: URS	Fugro Job #: 0305-1830
Date/Time: 3/29/2006 @ 7:38:00 AM	Max fluorescence: 189.91% @ 62.04 ft
ROST Unit: 5	Final depth BGS: 70.05 ft

P-60-03

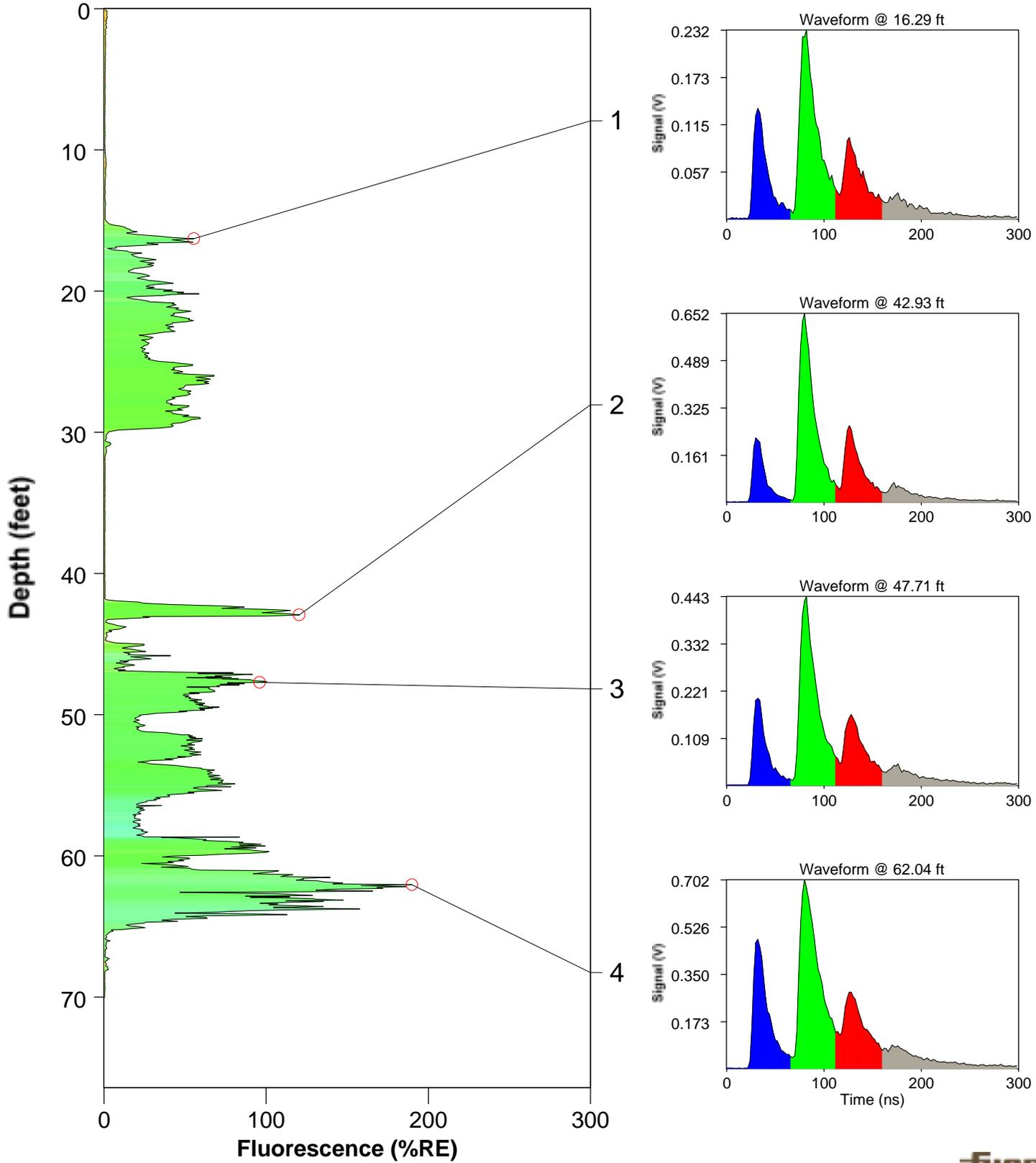

# ROST Fluorescence Response Data

Site: CONOCO PHILLIPS HARTFORD,IL.  
Client: URS  
Date/Time: 3/29/2006 @ 8:41:28 AM  
ROST Unit: 5

Operator: GLENN  
Fugro Job #: 0305-1830  
Max fluorescence: 76.20% @ 63.65 ft  
Final depth BGS: 70.07 ft

## P-60-04

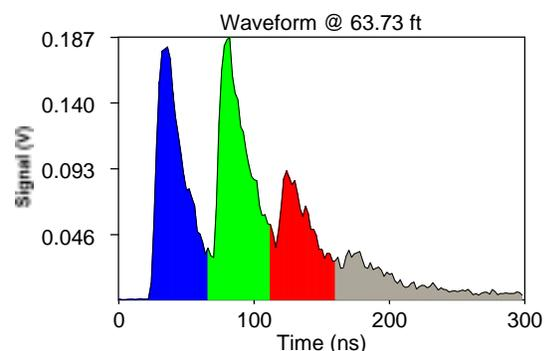
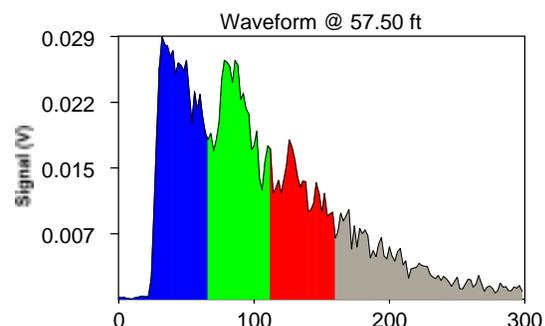
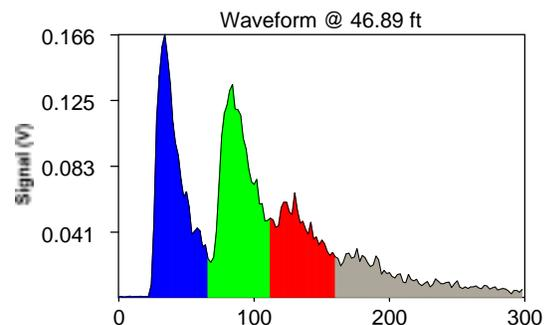
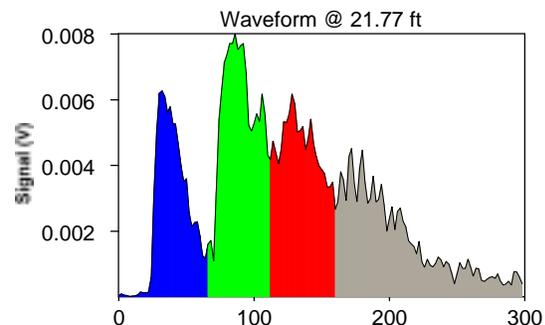
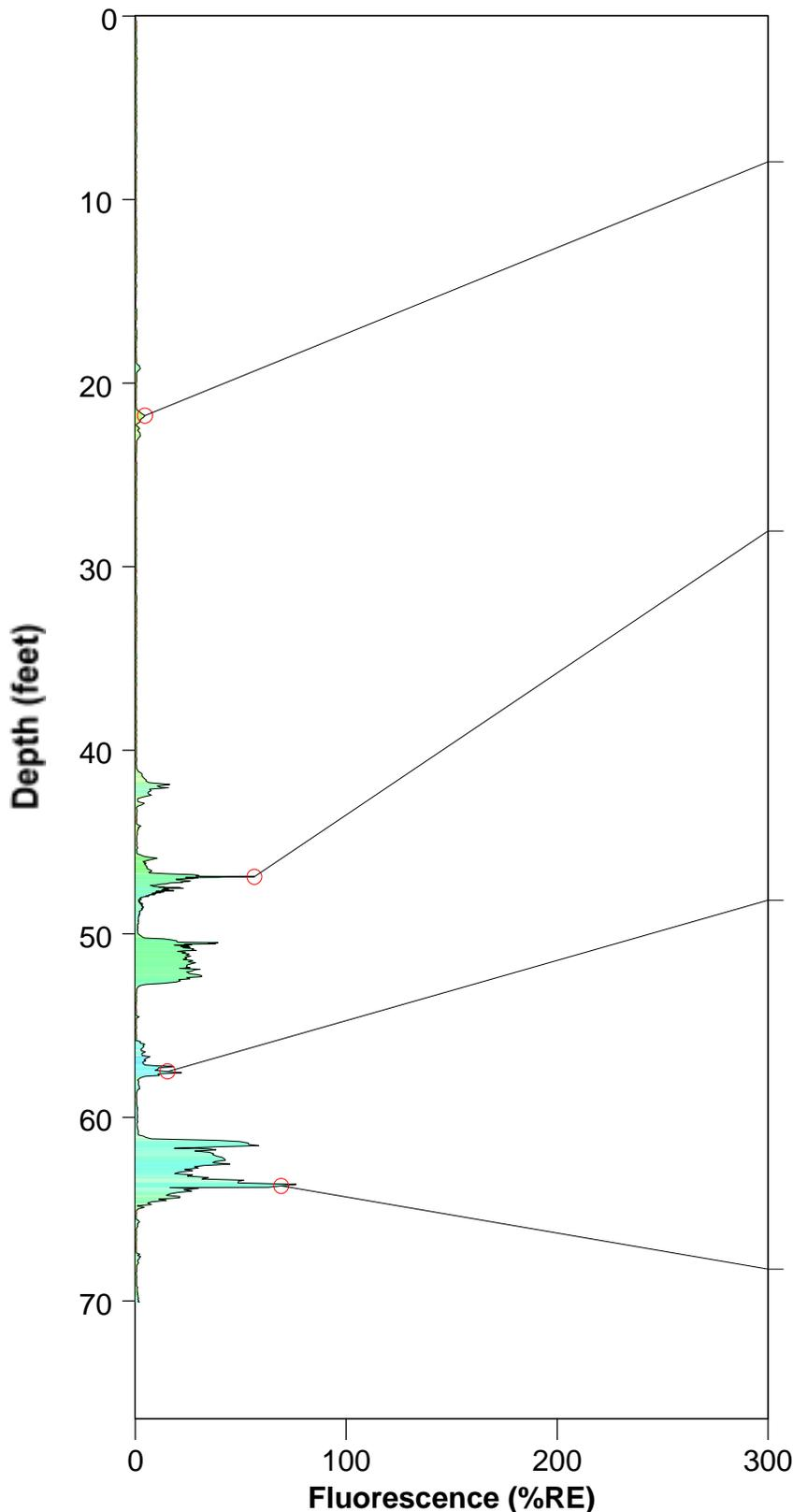

# ROST Fluorescence Response Data

Site: CONOCO PHILLIPS HARTFORD,IL.	Operator: GLENN
Client: URS	Fugro Job #: 0305-1830
Date/Time: 3/29/2006 @ 5:28:07 AM	Max fluorescence: 62.22% @ 56.66 ft
ROST Unit: 5	Final depth BGS: 70.04 ft

## P-60-07

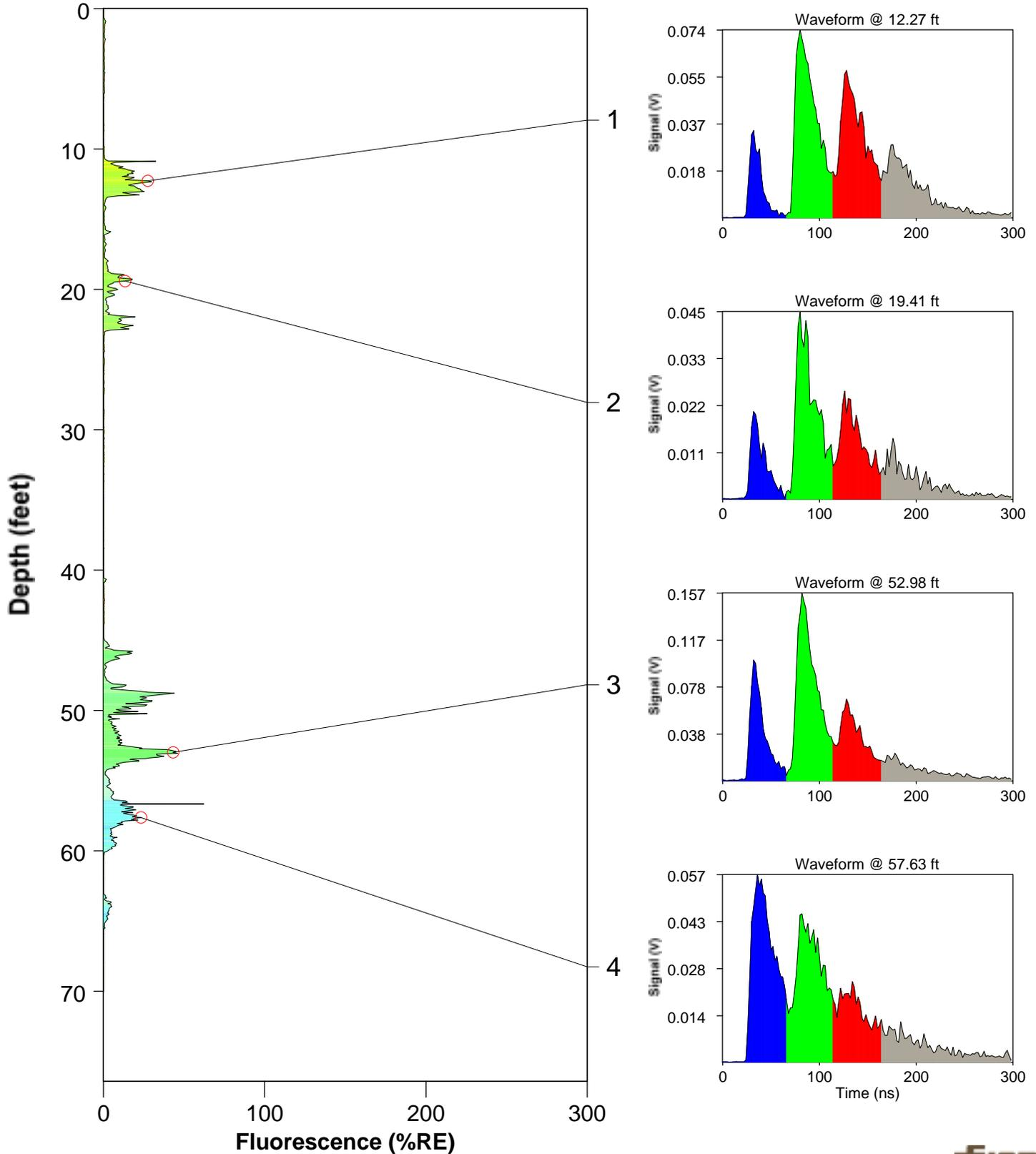

ROST Fluorescence Response Data

Site: CONOCO PHILLIPS HARTFORD,IL.  
Client: URS  
Date/Time: 3/29/2006 @ 6:32:23 AM  
ROST Unit: 5

Operator: GLENN  
Fugro Job #: 0305-1830  
Max fluorescence: 116.52% @ 15.53 ft  
Final depth BGS: 70.10 ft

P-60-08

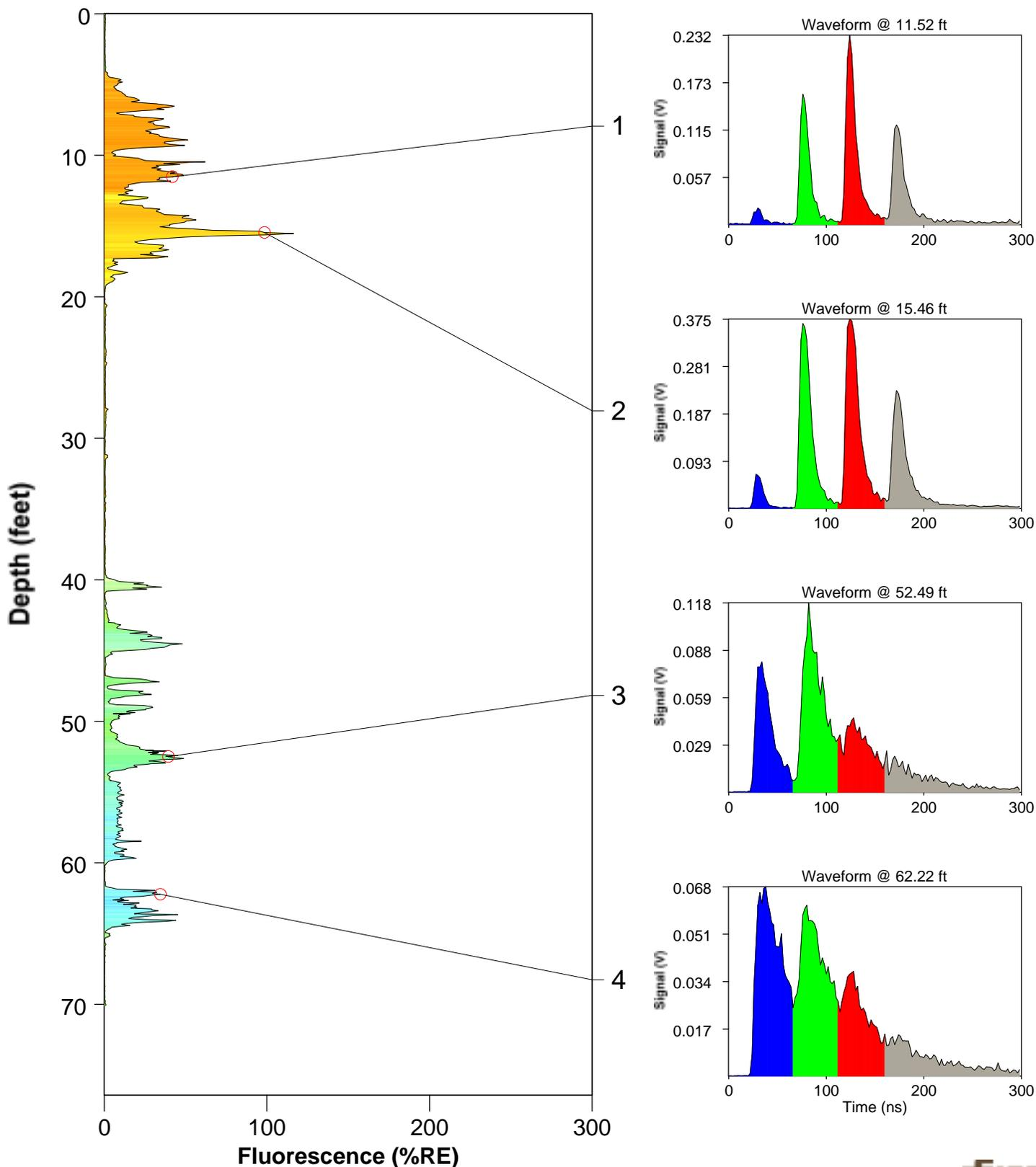

# ROST Fluorescence Response Data

Site: CONOCO PHILLIPS HARTFORD,IL.  
Client: URS  
Date/Time: 3/29/2006 @ 2:22:47 PM  
ROST Unit: 5

Operator: GLENN  
Fugro Job #: 0305-1830  
Max fluorescence: 72.95% @ 52.42 ft  
Final depth BGS: 70.14 ft

## P-60-09A

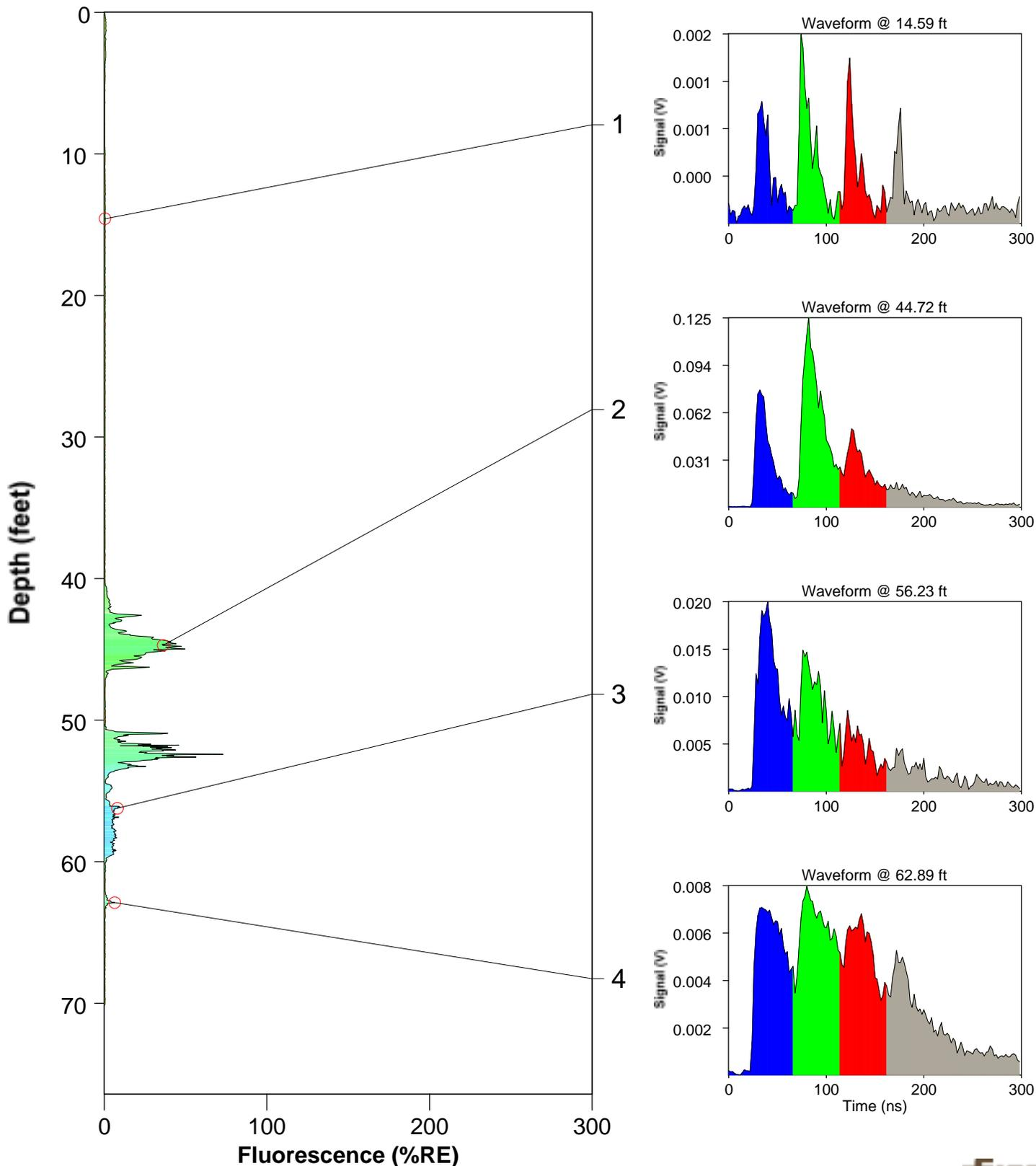

# ROST Fluorescence Response Data

Site: CONOCO PHILLIPS HARTFORD,IL.

Client: URS

Date/Time: 3/28/2006 @ 10:15:18 AM

ROST Unit: 5

Operator: GLENN

Fugro Job #: 0305-1830

Max fluorescence: 89.08% @ 46.92 ft

Final depth BGS: 70.11 ft

## P-60-10

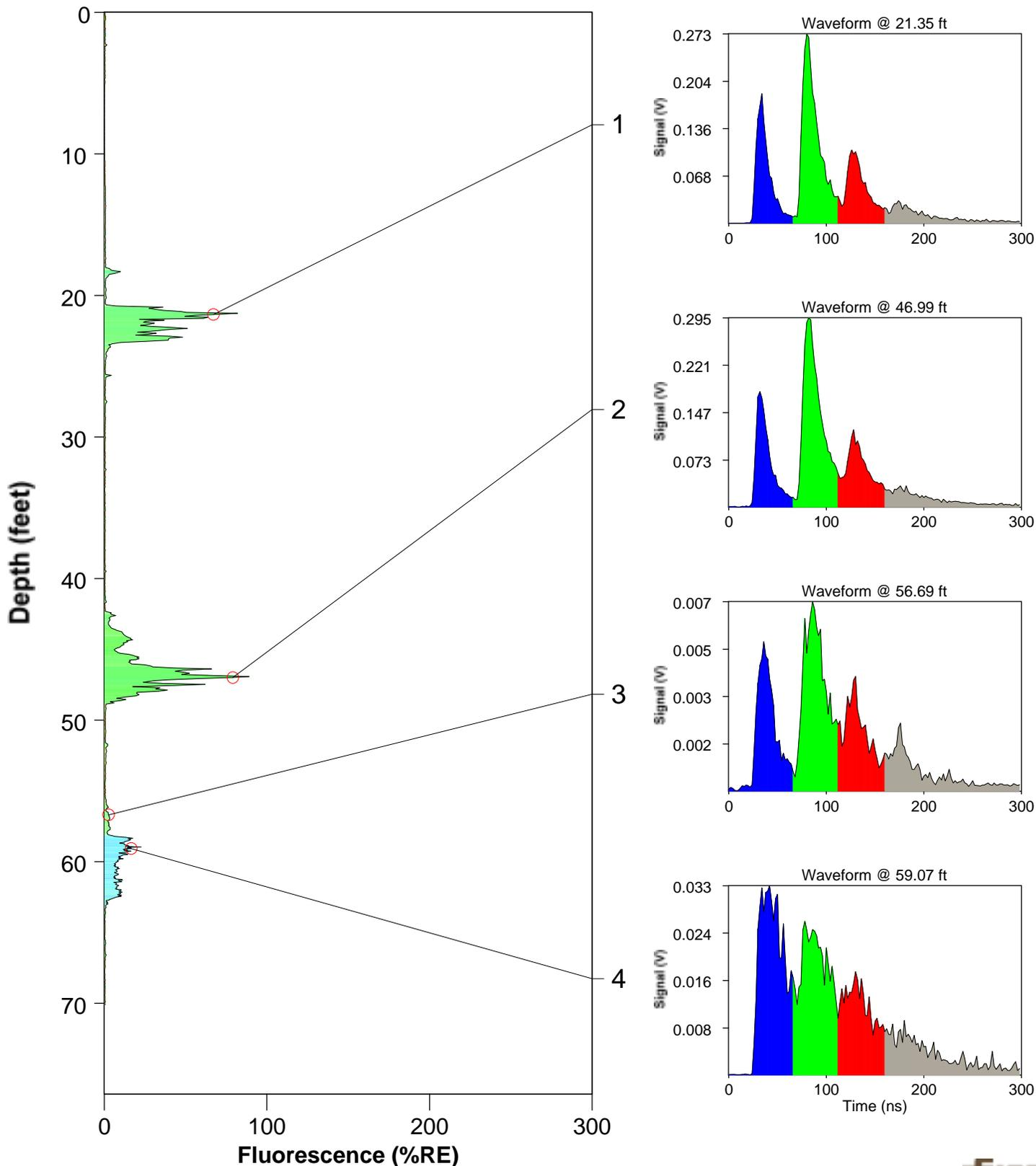

# ROST Fluorescence Response Data

Site: CONOCO PHILLIPS HARTFORD,IL.

Client: URS

Date/Time: 3/28/2006 @ 9:22:08 AM

ROST Unit: 5

Operator: GLENN

Fugro Job #: 0305-1830

Max fluorescence: 123.03% @ 52.65 ft

Final depth BGS: 70.07 ft

## P-60-11

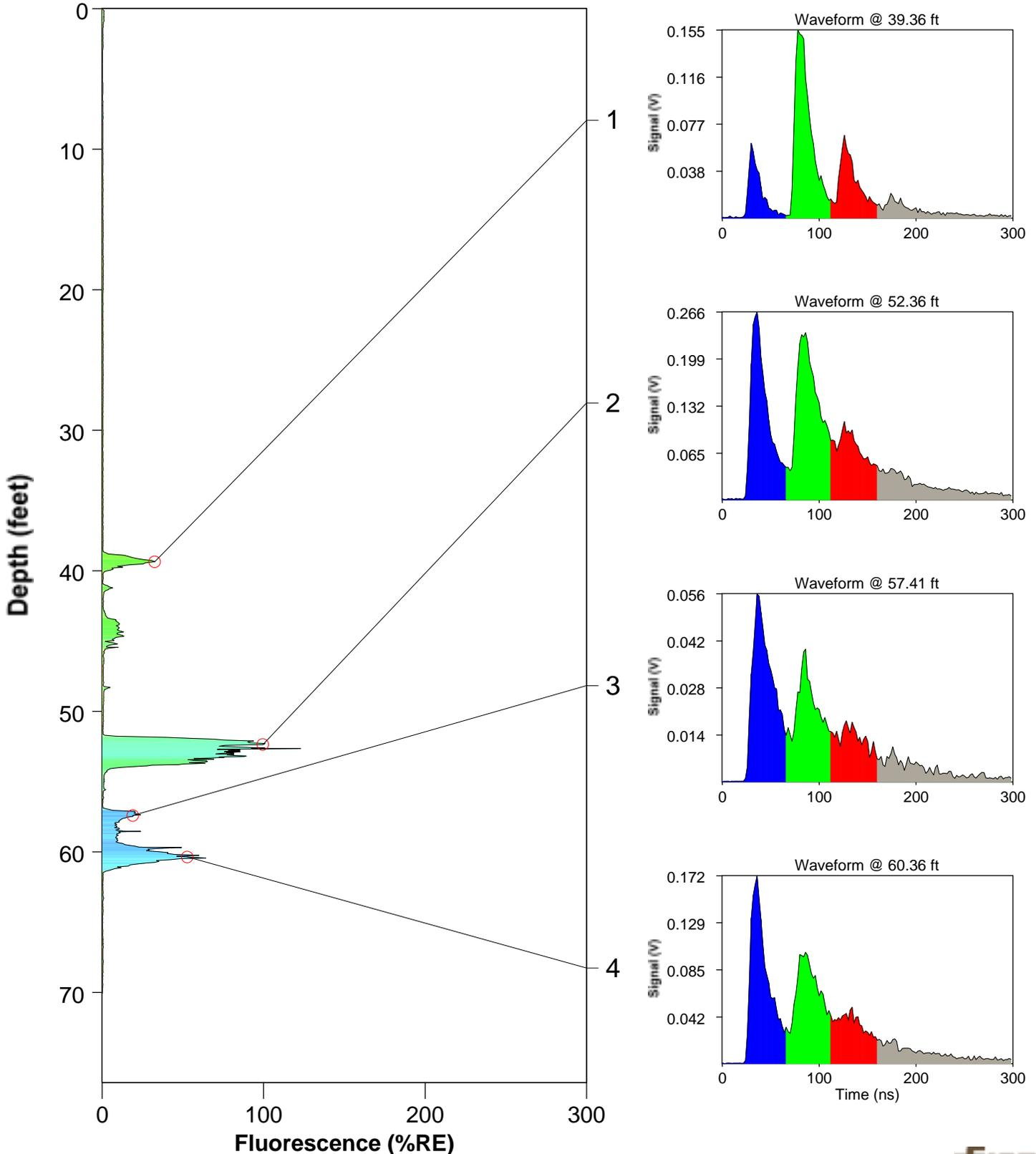

ROST Fluorescence Response Data

Site: CONOCO PHILLIPS HARTFORD,IL.  
Client: URS  
Date/Time: 3/28/2006 @ 7:43:46 AM  
ROST Unit: 5

Operator: GLENN  
Fugro Job #: 0305-1830  
Max fluorescence: 168.35% @ 19.10 ft  
Final depth BGS: 70.13 ft

P-60-12

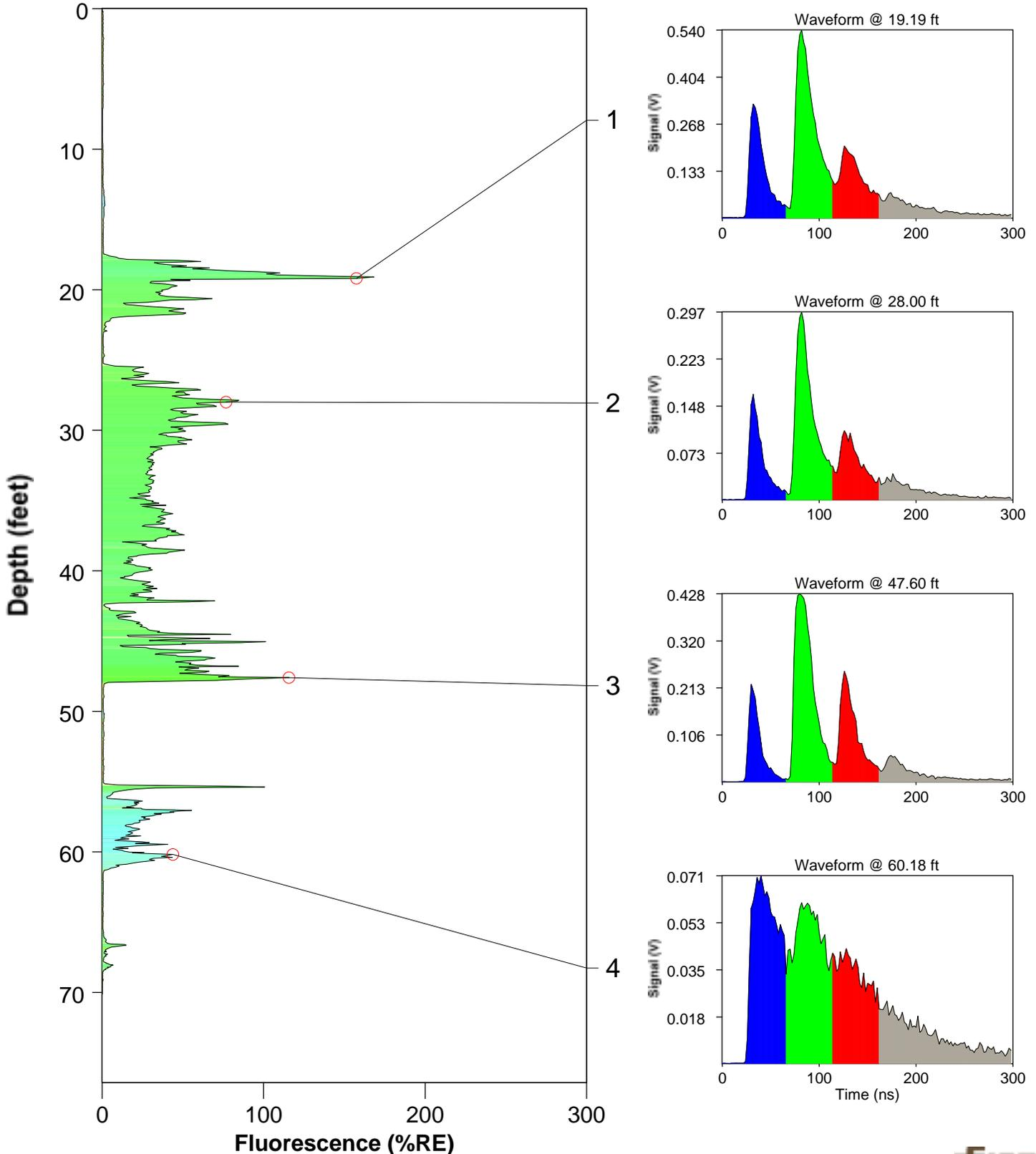



**LOG OF BORING  
P-60-03-GP**

Start Date: 4/18/06      Completion Date: 4/18/06      Coordinates: Northing: N/A  
 Boring Location:      Easting: N/A  
 Ground Elevation:

Depth In feet	Inches Driven	Inches Recovered	PID (ppm)	Sampler Graphic	Symbol	USCS	DESCRIPTION		NOTES
							DESCRIPTION	NOTES	
30	48	40	845			SP	Same: Dense, moist to dry, tan to gray, fine to medium grained, poorly graded SAND (SP)		
			643				With trace silt		
35	48	38	80.2			SP			
			35.8						
40	48	48	101			SP			
			439						
45	48	48	378			SP	Becomes wet	Hydrocarbon product	
			952						
								Bottom of boring at 44 ft bgs due to fumes/LEL readings. Backfilled using high solids bentonite grout.	

URS (ENVIRON) LOG 2008 21561665 CP WEST FENCE.GPJ URSSTLEV.GDT 9/19/08

Completion Depth: 44.00 ft bgs  
 Project No.: 21561665  
 Project Name: SOPUS - CP West Fenceline P-60 Investigation  
 Drilling Contractor: Roberts Environmental Drilling, Inc.  
 Drilling method: Geoprobe Rig Type: Geoprobe 6610DT  
 Drilled by: \_\_\_\_\_  
 Logged by: M. Miller



Water Depth: \_\_\_\_\_ ft., After \_\_\_\_\_ hrs.  
 Water Depth: \_\_\_\_\_ ft., After \_\_\_\_\_ hrs.

Water level ATD      ATD - At time of drilling  
 Water level after drilling       Hollow Stem Auger - Soil sampling not performed  
 Air Knife / Hand Auger Sampler       Split Spoon Sampler  
 Geoprobe - Soil sampling not performed  
 Geoprobe Sampler

Unified Soil Classification based on field visual observations.

### LOG OF BORING P-60-08-GP

Start Date: 4/14/06      Completion Date: 4/14/06  
Boring Location:

Coordinates: Northing: N/A  
Easting: N/A  
Ground Elevation:

Depth In feet	Inches Driven	Inches Recovered	PID (ppm)	Sampler Graphic	Symbol	USCS	DESCRIPTION	NOTES
0 - 10							Soil not logged until 10 ft bgs.	This location was air knifed to 10 ft bgs to clear utilities.
10 - 15	24	20	968			SP	Loose to medium dense, wet, brown, fine to medium grained, poorly graded SAND (SP)	Dark brown staining and strong odor (possible free product)
15 - 18	48	30	1215			SP		
18 - 20	24	22	1133			SP		
20 - 21	24	22	650			SC	Medium dense, wet, grayish brown, fine grained, poorly graded clayey SAND (SC)	End staining
21 - 22	24	20	129			SP	Medium dense, moist, brownish gray, fine to medium grained, poorly graded SAND (SP)	
22 - 20						CL	Medium stiff, moist, grayish brown, sandy CLAY (CL)	Bottom of boring at 20 ft bgs. Set piezometer with screen from 10-20 ft bgs.

URS (ENVIRON) LOG 2008 21561665 CP WEST FENCE GPJ URSSTLEV.GDT 9/19/08

Completion Depth: 20.00 ft bgs  
Project No.: 21561665  
Project Name: SOPUS - CP West Fenceline P-60 Investigation  
Drilling Contractor: Roberts Environmental Drilling, Inc.  
Drilling method: Geoprobe Rig Type: Geoprobe 6610DT  
Drilled by: \_\_\_\_\_  
Logged by: M. Miller

Water Depth: \_\_\_\_\_ ft., After \_\_\_\_\_ hrs.  
Water Depth: \_\_\_\_\_ ft., After \_\_\_\_\_ hrs.

Water level ATD      ATD - At time of drilling  
 Water level after drilling       Hollow Stem Auger - Soil sampling not performed  
 Air Knife / Hand Auger Sampler       Split Spoon Sampler  
 Unified Soil Classification based on field visual observations.       Geoprobe - Soil sampling not performed  
 Geoprobe Sampler



### LOG OF BORING P-60-09-GP

Start Date: 4/18/06      Completion Date: 4/18/06  
Boring Location:

Coordinates:    Northing: N/A  
                         Easting: N/A  
                         Ground Elevation:

Depth In feet	Inches Driven	Inches Recovered	PID (ppm)	Sampler Graphic	Symbol	USCS
---------------	---------------	------------------	-----------	-----------------	--------	------

DESCRIPTION

NOTES

5						
10						
15						
20						

Soil not logged until 44 ft bgs.

This location was air knifed to 10 ft bgs to clear utilities.

URS (ENVIRON) LOG 2008 21561665 CP WEST FENCE.GPJ URSSTLEV.GDT 9/19/08

Completion Depth: 56.00 ft bgs  
Project No.: 21561665  
Project Name: SOPUS - CP West Fenceline P-60 Investigation  
Drilling Contractor: Roberts Environmental Drilling, Inc.  
Drilling method: Geoprobe      Rig Type: Geoprobe 6610DT  
Drilled by: \_\_\_\_\_  
Logged by: M. Miller



Water Depth: \_\_\_\_\_ ft., After \_\_\_\_\_ hrs.  
Water Depth: \_\_\_\_\_ ft., After \_\_\_\_\_ hrs.

- Water level ATD      ATD - At time of drilling
- Water level after drilling       Hollow Stem Auger - Soil sampling not performed
- Air Knife / Hand Auger Sampler       Split Spoon Sampler
- Unified Soil Classification based on field visual observations.       Geoprobe - Soil sampling not performed
- Geoprobe Sampler

### LOG OF BORING P-60-09-GP

Start Date: 4/18/06      Completion Date: 4/18/06      Coordinates: Northing: N/A  
 Boring Location:      Easting: N/A  
 Ground Elevation:

Depth In feet	Inches Driven	Inches Recovered	PID (ppm)	Sampler Graphic	Symbol	USCS	DESCRIPTION	NOTES
30							Soil not logged until 44 ft bgs.	
35								
40								
45	48	48	1245			SP	Medium dense, wet, brownish gray, fine to medium grained, poorly graded SAND (SP)	
			81.1			CL	Medium stiff, wet, gray, low plasticity sandy CLAY (CL)	
	48	48	53.7				With trace sand Becomes sandy	

URS (ENVIRON) LOG 2008 21561665 CP WEST FENCE.GPJ URSSTLEV.GDT 9/19/08

Completion Depth: 56.00 ft bgs  
 Project No.: 21561665  
 Project Name: SOPUS - CP West Fenceline P-60 Investigation  
 Drilling Contractor: Roberts Environmental Drilling, Inc.  
 Drilling method: Geoprobe Rig Type: Geoprobe 6610DT  
 Drilled by: \_\_\_\_\_  
 Logged by: M. Miller

Water Depth: \_\_\_\_\_ ft., After \_\_\_\_\_ hrs.  
 Water Depth: \_\_\_\_\_ ft., After \_\_\_\_\_ hrs.  
 Water level ATD      ATD - At time of drilling  
 Water level after drilling       Hollow Stem Auger - Soil sampling not performed  
 Air Knife / Hand Auger Sampler       Split Spoon Sampler  
 Unified Soil Classification based on field visual observations.       Geoprobe - Soil sampling not performed  
 Geoprobe Sampler



**LOG OF BORING  
P-60-09-GP**

Start Date: 4/18/06  
Completion Date: 4/18/06  
Boring Location:

Coordinates: Northing: N/A  
Easting: N/A  
Ground Elevation:

Depth In feet	Inches Driven	Inches Recovered	PID (ppm)	Sampler Graphic	Symbol	USCS	DESCRIPTION	NOTES
55			923	[Black diamond]	[Diagonal lines]	CL	Same: Medium stiff, wet, gray, low plasticity sandy CLAY (CL)	Distinct sheen & hydrocarbon odor
			876					
	24	24	603	[Black diamond]	[Stippled]	SP	Dense, wet, grayish brown, fine to medium grained, poorly graded SAND (SP), with trace clay	
			326					
24	24	597	[Black diamond]	[Stippled]			Bottom of boring at 56 ft bgs. Set piezometer with screen from 41-56 ft bgs.	
60								
65								
70								

Completion Depth: 56.00 ft bgs  
Project No.: 21561665  
Project Name: SOPUS - CP West Fenceline P-60 Investigation  
Drilling Contractor: Roberts Environmental Drilling, Inc.  
Drilling method: Geoprobe Rig Type: Geoprobe 6610DT  
Drilled by: \_\_\_\_\_  
Logged by: M. Miller

Water Depth: \_\_\_\_\_ ft., After \_\_\_\_\_ hrs.  
Water Depth: \_\_\_\_\_ ft., After \_\_\_\_\_ hrs.  
▼ Water level ATD      ATD - At time of drilling  
☒ Water level after drilling      □ Hollow Stem Auger - Soil sampling not performed  
☺ Air Knife / Hand Auger Sampler      ■ Split Spoon Sampler  
☒ Geoprobe - Soil sampling not performed  
☒ Geoprobe Sampler



URS (ENVIRON) LOG 2008 21561665 CP WEST FENCE GPJ URSSTLEV.GDT 9/19/08

## LOG OF BORING P-60-10-GP

Start Date: 4/17/06      Completion Date: 4/17/06      Coordinates: Northing: N/A  
 Boring Location:      Easting: N/A  
 Ground Elevation:

Depth In feet	Inches Driven	Inches Recovered	PID (ppm)	Sampler Graphic	Symbol	USCS	DESCRIPTION	NOTES
5							Soil not logged until 20 ft bgs.	This location air knifed to 10 ft bgs to clear utilities.
10								
15								Poor recovery due to shattered liner.
20	48	0					Medium dense, moist, grayish tan, fine to medium grained, poorly graded SAND (SP), with trace silty clay	
	48	36	1039		SP			
	48	48	878		SP		Becomes dense, moist to dry, greenish gray to gray, fine grained, silty clay grades out	

URS (ENVIRON) LOG 2008 21561665 CP WEST FENCE GPJ URSSTLEV.GDT 9/19/08

Completion Depth: 62.00 ft bgs  
 Project No.: 21561665  
 Project Name: SOPUS - CP West Fenceline P-60 Investigation  
 Drilling Contractor: Roberts Environmental Drilling, Inc.  
 Drilling method: Geoprobe      Rig Type: Geoprobe 6610DT  
 Drilled by: \_\_\_\_\_  
 Logged by: M. Miller



Water Depth: \_\_\_\_\_ ft., After \_\_\_\_\_ hrs.  
 Water Depth: \_\_\_\_\_ ft., After \_\_\_\_\_ hrs.

Water level ATD      ATD - At time of drilling  
 Water level after drilling       Hollow Stem Auger - Soil sampling not performed  
 Air Knife / Hand Auger Sampler       Split Spoon Sampler  
 Unified Soil Classification based on field visual observations.       Geoprobe - Soil sampling not performed  
 Geoprobe Sampler



**LOG OF BORING  
P-60-10-GP**

Start Date: 4/17/06      Completion Date: 4/17/06      Coordinates:    Northing: N/A  
 Boring Location:      Easting: N/A  
 Ground Elevation:

Depth In feet	Inches Driven	Inches Recovered	PID (ppm)	Sampler Graphic	Symbol	USCS	DESCRIPTION	NOTES
55	48	48	20.7			CL	Same: stiff, moist to wet, gray, low plasticity CLAY (CL), with fine sand  Fine sand grades out	
60	48	36	68.0				With fine sand	
60	24	20	834			SP	Dense, wet, tan, fine to medium grained, poorly graded SAND (SP)	Poor recovery due to shattered liner.
65			751					
70			881					Bottom of boring at 62 ft bgs.

Completion Depth: 62.00 ft bgs

Project No.: 21561665

Project Name: SOPUS - CP West Fenceline P-60 Investigation

Drilling Contractor: Roberts Environmental Drilling, Inc.

Drilling method: Geoprobe      Rig Type: Geoprobe 6610DT

Drilled by: \_\_\_\_\_

Logged by: M. Miller

Water Depth: \_\_\_\_\_ ft., After \_\_\_\_\_ hrs.

Water Depth: \_\_\_\_\_ ft., After \_\_\_\_\_ hrs.

▼ Water level ATD

ATD - At time of drilling

∇ Water level after drilling

Hollow Stem Auger - Soil sampling not performed

⊞ Air Knife / Hand Auger Sampler

■ Split Spoon Sampler

Unified Soil Classification based on field visual observations.

Geoprobe - Soil sampling not performed

Geoprobe Sampler



### LOG OF BORING P-60-11-GP

Depth In feet	Inches Driven	Inches Recovered	PID (ppm)	Sampler Graphic	Symbol	USCS	Description	Notes
							Start Date: 4/14/06      Completion Date: 4/14/06	Coordinates: Northing: N/A Easting: N/A Ground Elevation:
5							Soil not logged until 44 ft bgs.	This location air knifed to 10 ft bgs to clear utilities.
10								
15							Boring advanced to 44 ft bgs with isolation point.	
20								

URS (ENVIRON) LOG 2008 21561665 CP WEST FENCE.GPJ URSSTLEV.GDT 9/19/08

Completion Depth: 66.00 ft bgs  
 Project No.: 21561665  
 Project Name: SOPUS - CP West Fenceline P-60 Investigation  
 Drilling Contractor: Roberts Environmental Drilling, Inc.  
 Drilling method: Geoprobe      Rig Type: Geoprobe 6610DT  
 Drilled by: \_\_\_\_\_  
 Logged by: M. Miller



Water Depth: 49 ft., After ATD hrs.  
 Water Depth: 49 ft., After ATD hrs.

<input checked="" type="checkbox"/> Water level ATD	ATD - At time of drilling
<input type="checkbox"/> Water level after drilling	<input type="checkbox"/> Hollow Stem Auger - Soil sampling not performed
<input checked="" type="checkbox"/> Air Knife / Hand Auger Sampler	<input checked="" type="checkbox"/> Split Spoon Sampler
Unified Soil Classification based on field visual observations.	<input type="checkbox"/> Geoprobe - Soil sampling not performed
	<input checked="" type="checkbox"/> Geoprobe Sampler

# LOG OF BORING P-60-11-GP

Start Date: 4/14/06      Completion Date: 4/14/06  
 Boring Location:      Coordinates: Northing: N/A  
    Easting: N/A  
    Ground Elevation:

Depth In feet	Inches Driven	Inches Recovered	PID (ppm)	Sampler Graphic	Symbol	USCS	LOG OF BORING P-60-11-GP		
							DESCRIPTION	NOTES	
							Soil not logged until 44 ft bgs.		
30									
35									
40									
45	48	48	36.2			SP	Medium dense, dry to moist, tan, fine to medium grained, poorly graded SAND (SP)		
			19.5			CL	Medium stiff, moist, grayish brown, low plasticity sandy CLAY (CL), with trace silt		
	41.7	48	48				SC	Medium dense, wet, grayish brown, fine grained, poorly graded clayey SAND (SC), with trace medium sand	
								CL	Stiff, moist, grayish brown, low plasticity sandy CLAY (CL)
							SP	Medium dense, wet, gray, fine grained, poorly graded SAND (SP)	

Completion Depth: 66.00 ft bgs  
 Project No.: 21561665  
 Project Name: SOPUS - CP West Fenceline P-60 Investigation  
 Drilling Contractor: Roberts Environmental Drilling, Inc.  
 Drilling method: Geoprobe      Rig Type: Geoprobe 6610DT  
 Drilled by: \_\_\_\_\_  
 Logged by: M. Miller

Water Depth: 49 ft., After ATD hrs.  
 Water Depth: 49 ft., After ATD hrs.  
 Water level ATD      ATD - At time of drilling  
 Water level after drilling  
 Hollow Stem Auger - Soil sampling not performed  
 Air Knife / Hand Auger Sampler       Split Spoon Sampler  
 Unified Soil Classification based on field visual observations.       Geoprobe - Soil sampling not performed  
 Geoprobe Sampler



URS (ENVIRON) LOG 2008 21561665 CP WEST FENCE GPJ URSSTLEV.GDT 9/19/08



LOG OF BORING  
P-60-12-GP(S)

Start Date: 4/19/06  
Completion Date: 4/19/06  
Boring Location:

Coordinates: Northing: N/A  
Easting: N/A  
Ground Elevation:

Depth In feet	Inches Driven	Inches Recovered	PID (ppm)	Sampler Graphic	Symbol	USCS	DESCRIPTION	NOTES
0 - 10							Soil not logged until 10 ft bgs.	This location air knifed to 10 ft bgs to clear utilities.
10 - 15	24	22	33.1	[Diamond]	[Dotted]	SP	Dense, moist, tan, fine to medium grained, poorly graded SAND (SP)	3" black staining
15 - 20	48	36	16.2	[Diamond]	[Dotted]	SP		
			12.9	[Diamond]	[Dotted]		Becomes wet	Strong hydrocarbon odor
	48	40	39.4	[Diamond]	[Dotted]			
			891	[Diamond]	[Dotted]			
20 - 24	48	42	797	[Diamond]	[Dotted]	SP	Medium stiff, wet, greenish gray, sandy SILT (ML) Dense, wet, tan, fine to medium grained, poorly graded SAND (SP)	
				[Diamond]	[Dotted]		Becomes greenish gray	
			77.6	[Diamond]	[Dotted]		Becomes tan	
24								Bottom of boring at 24 ft bgs. Set piezometer with screen from 20-24 ft bgs.

URS (ENVIRON) LOG 2008 21561665 CP WEST FENCE.GPJ\_URSSTLEV.GDT 9/19/08

Completion Depth: 24.00 ft bgs  
Project No.: 21561665  
Project Name: SOPUS - CP West Fenceline P-60 Investigation  
Drilling Contractor: Roberts Environmental Drilling, Inc.  
Drilling method: Geoprobe Rig Type: Geoprobe 6610DT  
Drilled by: \_\_\_\_\_  
Logged by: M. Miller



Water Depth: \_\_\_\_\_ ft., After \_\_\_\_\_ hrs.  
Water Depth: \_\_\_\_\_ ft., After \_\_\_\_\_ hrs.  
▼ Water level ATD  
⊖ Water level after drilling  
⊞ Air Knife / Hand Auger Sampler  
☐ Hollow Stem Auger - Soil sampling not performed  
◼ Split Spoon Sampler  
▣ Geoprobe - Soil sampling not performed  
⊠ Geoprobe Sampler

## LOG OF BORING AND WELL CONSTRUCTION DETAIL P-60-12-GP / P-60 (II)

NOTE: P-60-12-GP is located about 5 ft East of P-60 (II)

Completion  
Date: 4/12/06  
Casing Elevation:  
Ground Elevation:

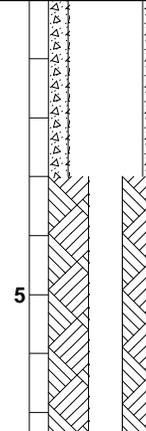
Depth in feet	Well Construction	Inches Driven	Inches Recovered	PID (ppm)	Sampler Graphic	Symbol	USCS	DESCRIPTION	NOTES
0 to 10								Soil not logged until 10 ft bgs.	This location air knifed to 10 ft bgs to clear utilities.
10 to 13.4		24	24	9.8				Medium dense, dry, grayish tan, fine grained, poorly graded SAND (SP), with trace silt	
13.4 to 16.4		48	36	3.4			SP	Hydrocarbon odor, slight staining	
16.4 to 19.9		48	36	6.4				Dark gray staining	
19.9 to 21.7				10.9				Medium stiff, moist, light gray, SILT (ML), with trace clay and fine sand	
21.7 to 23.9		48	32	1091				Medium dense, dry, tan, fine grained, poorly graded SAND (SP)	Slough collected 20 -24 ft bgs. Wet with hydrocarbon sheen & odor (PID 1204)
23.9 to 25.7		48	32	1186			SP		
25.7 to 26.1		24	24	84.0			CL	Medium stiff, moist, brown, silty CLAY (CL)	

URS (ENVIRON) LOG + 1 WELL RAND\_ 21561665 CP WEST FENCE.GPJ\_URSTLEV.GDT\_ 8/7/06

Completion Depth: 71.00 ft bgs  
 Project No.: 21561665.00002  
 Project Name: SOPUS - CP West Fenceline P-60 Investigation  
 Drilling Contractor: Roberts Environmental Drilling, Inc.  
 Drilling method: Geoprobe  
 Logged by: M. Miller

Water Depth: \_\_\_\_\_ ft., After \_\_\_\_\_ hrs.  
 Water Depth: \_\_\_\_\_ ft., After \_\_\_\_\_ hrs.  
 Water level at time of drilling  
 Water level after drilling  
 3" Clear Acetate Liner  
 Hollow Stem Auger  
 Air Knife  
 ATD - At time of drilling

Geoprobe Macro Sampler  
 Hand Auger Sampler  
 Unified Soil Classification based on field visual observations.



**LOG OF BORING AND WELL CONSTRUCTION DETAIL**  
**P-60-12-GP / P-60 (II)**

NOTE: P-60-12-GP is located about 5 ft East of P-60 (II)

Completion  
 Date: 4/12/06  
 Casing Elevation:  
 Ground Elevation:

Depth In feet	Well Construction	Inches Driven	Inches Recovered	PID (ppm)	Sampler Graphic	Symbol	USCS	Completion	NOTES
								DESCRIPTION	
				94.3					Medium dense to dense, dry to moist, grayish tan, fine grained, poorly graded SAND (SP), with trace silt
		24	24	954	◆				
		24	24	568	◆				
30		24	24	682	◆				
		24	24	720	◆				
35		24	24	815	◆		SP		
		24	24	761	◆				
		48	24	360	◆				Poor recovery due to shattered liner.
40		24	24		◆				
		48	24	45.7	◆				
45		24	24		◆				
		24	24	47.9	◆		CL SM CL	Stiff, moist, gray, low plasticity CLAY (CL) Loose, wet, gray, fine grained, poorly graded silty SAND (SM)	
				1072	◆			Stiff, moist, gray, low plasticity silty CLAY (CL)	
		24	24	458	◆		SP	Medium dense to dense, moist, tan, fine to medium grained, poorly graded SAND (SP) Becomes wet	Strong hydrocarbon odor & sheen present

Completion Depth: 71.00 ft bgs  
 Project No.: 21561665.00002  
 Project Name: SOPUS - CP West Fenceline P-60 Investigation  
 Drilling Contractor: Roberts Environmental Drilling, Inc.  
 Drilling method: Geoprobe  
 Logged by: M. Miller

Water Depth: \_\_\_\_\_ ft., After \_\_\_\_\_ hrs.  
 Water Depth: \_\_\_\_\_ ft., After \_\_\_\_\_ hrs.  
 ▽ Water level at time of drilling  
 ▽ Water level after drilling      ☒ Geoprobe Macro Sampler  
 █ 3" Clear Acetate Liner                ☒ Hand Auger Sampler  
 ☒ Hollow Stem Auger                        Unified Soil Classification based on field visual observations.  
 ☒ Air Knife  
 ATD - At time of drilling



URS (ENVIRON) LOG + 1 WELL RAND 21561665 CP WEST FENCE.GPJ URSSTLEV.GDT 8/1/06

# LOG OF BORING AND WELL CONSTRUCTION DETAIL

## P-60-12-GP / P-60 (II)

NOTE: P-60-12-GP is located about 5 ft East of P-60 (II)

Depth In feet

P-60 (II)  
Well Construction

Inches Driven

Inches Recovered

PID (ppm)

Sampler Graphic

Symbol

USCS

Completion  
Date: 4/12/06  
Casing Elevation:  
Ground Elevation:

DESCRIPTION

NOTES

55  
60  
65  
70

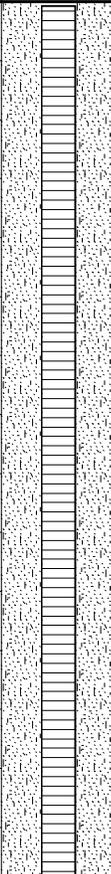

Inches Driven	Inches Recovered	PID (ppm)
24	24	568
48	48	62.1
		74.3
48	48	14.1
		67.1
24	24	778
24	24	644
48	20	869
36	12	289

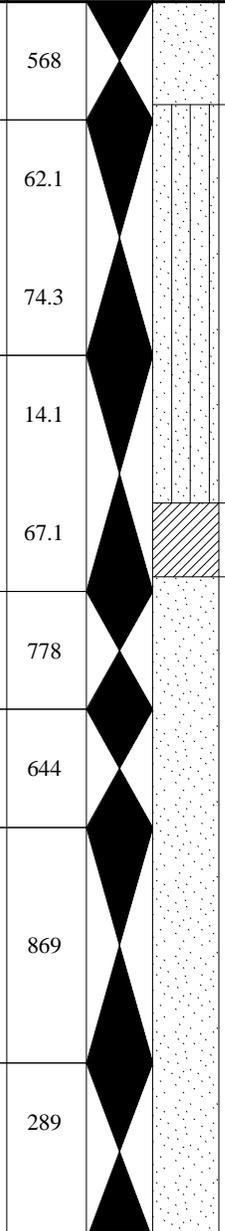

SP  
SM  
CL  
SP

Same: Medium dense to dense, wet, tan, fine to medium grained, poorly graded SAND (SP)  
  
Dense, wet, gray to dark gray, fine grained, poorly graded silty SAND (SM), with clay  
  
Stiff, wet, gray, low plasticity CLAY (CL), with trace fine sand  
  
Dense, wet, grayish tan, fine to medium grained, poorly graded SAND (SP)

Slight staining on gloves.  
Strong hydrocarbon odor  
  
  
  
  
Bottom of boring at 71 ft bgs. Set piezometer with screen from 61 - 71 ft bgs.

Completion Depth: 71.00 ft bgs  
Project No.: 21561665.00002  
Project Name: SOPUS - CP West Fenceline P-60 Investigation  
Drilling Contractor: Roberts Environmental Drilling, Inc.  
Drilling method: Geoprobe  
Logged by: M. Miller

Water Depth: \_\_\_\_\_ ft., After \_\_\_\_\_ hrs.  
Water Depth: \_\_\_\_\_ ft., After \_\_\_\_\_ hrs.  
∇ Water level at time of drilling  
▽ Water level after drilling  
■ 3" Clear Acetate Liner  
□ Hollow Stem Auger  
▨ Air Knife  
ATD - At time of drilling  
⊗ Geoprobe Macro Sampler  
⊞ Hand Auger Sampler  
Unified Soil Classification based on field visual observations.



**STICK UP MONITORING WELL CONSTRUCTION DIAGRAM**

GROUND SURFACE ELEVATION Currently Not Available (CNA)  
TOP OF INNER WELL CASING ELEVATION 446.78  
DATUM NAVD 88 - 1988 USGS Datum

JOB NUMBER 21561665  
BORING NUMBER P-60(II) [replacement well for P-60]  
INSTALLATION DATE 4/19/2006  
LOCATION ConocoPhillips Wood River Refinery

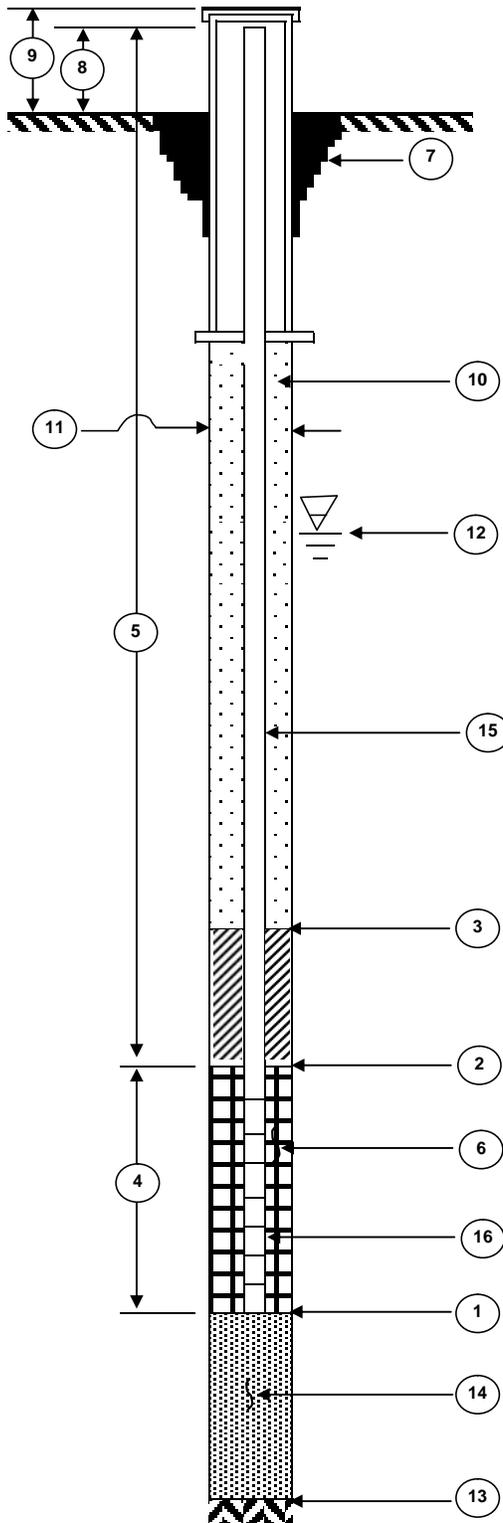

- 1 DEPTH TO BOTTOM OF WELL POINT OR SLOTTED PIPE 65 FEET.\*
- 2 DEPTH TO TOP OF FILTER PACK 41 FEET.\*
- 3 DEPTH TO TOP OF SEAL 37 FEET.\*
- 4 LENGTH OF WELL SCREEN 20 FEET.  
SLOT SIZE 0.020 INCHES.
- 5 TOTAL LENGTH OF RISER PIPE 48 FEET AT  
4 INCH DIAMETER.
- 6 TYPE OF PACK AROUND WELL POINT OR SLOTTED PIPE  
Colorado Silica 814
- 7 CONCRETE CAP? YES NO (CIRCLE ONE)
- 8 HEIGHT OF WELL CASING ABOVE GROUND 3 FEET.
- 9 PROTECTIVE CASING YES NO (CIRCLE ONE)  
HEIGHT ABOVE GROUND 3.3 FEET.  
LOCKING CAP? YES NO (CIRCLE ONE)
- 10 TYPE OF UPPER BACKFILL High Solids Bentonite Grout
- 11 BOREHOLE DIAMETER 10.75 INCHES
- 12 DEPTH TO GROUND WATER 49.04 FEET BTOC ON 4/27/06
- 13 TOTAL DEPTH OF BOREHOLE 65 FEET.\*
- 14 TYPE OF LOWER BACKFILL N/A
- 15 PIPE MATERIAL Stainless Steel (304)
- 16 SCREEN MATERIAL Stainless Steel (304)

\* (DEPTH FROM GROUND SURFACE)

MONITOR WELL INSTALLATION DETAILS





# **Analytical Report 309779**

**for**

**URS Corporation-St. Louis**

**Project Manager: Wendy Pennington**

**900 S. Central Avenue**

**Route 111 & Rand Ave Vicinity / 21561979**

**18-AUG-08**



**E84880**

**4143 Greenbriar Dr., Stafford, TX 77477 Ph:(281) 240-4200 Fax:(281) 240-4280**

Texas certification numbers:

Houston, TX T104704215 - Odessa/Midland, TX T104704215-08-TX

Florida certification numbers:

Houston, TX E871002 - Miami, FL E86678 - Tampa, FL E86675  
Norcross(Atlanta), GA E87429

South Carolina certification numbers:

Norcross(Atlanta), GA 98015

North Carolina certification numbers:

Norcross(Atlanta), GA 483

Houston - Dallas - San Antonio - Austin - Tampa - Miami - Latin America  
Midland - Corpus Christi - Atlanta

18-AUG-08

Project Manager: **Wendy Pennington**  
**URS Corporation-St. Louis**  
1001 Highlands Plaza Drive West, Suite 300  
St. Louis, MO 63110

Reference: XENCO Report No: **309779**  
**900 S. Central Avenue**  
Project Address: Roxana, Illinois 62084

**Wendy Pennington:**

We are reporting to you the results of the analyses performed on the samples received under the project name referenced above and identified with the XENCO Report Number 309779. All results being reported under this Report Number apply to the samples analyzed and properly identified with a Laboratory ID number. Subcontracted analyses are identified in this report with either the NELAC certification number of the subcontract lab in the analyst ID field, or the complete subcontracted report attached to this report.

Unless otherwise noted in a Case Narrative, all data reported in this Analytical Report are in compliance with NELAC standards. Estimation of data uncertainty for this report is found in the quality control section of this report unless otherwise noted. Should insufficient sample be provided to the laboratory to meet the method and NELAC Matrix Duplicate and Matrix Spike requirements, then the data will be analyzed, evaluated and reported using all other available quality control measures.

The validity and integrity of this report will remain intact as long as it is accompanied by this letter and reproduced in full, unless written approval is granted by XENCO Laboratories. This report will be filed for at least 5 years in our archives after which time it will be destroyed without further notice, unless otherwise arranged with you. The samples received, and described as recorded in Report No. 309779 will be filed for 60 days, and after that time they will be properly disposed without further notice, unless otherwise arranged with you. We reserve the right to return to you any unused samples, extracts or solutions related to them if we consider so necessary (e.g., samples identified as hazardous waste, sample sizes exceeding analytical standard practices, controlled substances under regulated protocols, etc).

We thank you for selecting XENCO Laboratories to serve your analytical needs. If you have any questions concerning this report, please feel free to contact us at any time.

Respectfully,



---

**Carlos Castro**

Managing Director, Texas

***Recipient of the Prestigious Small Business Administration Award of Excellence in 1994.***

*Certified and approved by numerous States and Agencies.*

*A Small Business and Minority Status Company that delivers SERVICE and QUALITY*

Houston - Dallas - San Antonio - Austin - Tampa - Miami - Atlanta - Corpus Christi - Latin America



## Sample Cross Reference 309779



**URS Corporation-St. Louis, St. Louis, MO**  
900 S. Central Avenue

Sample Id	Matrix	Date Collected	Sample Depth	Lab Sample Id
T-1080808	W	Aug-08-08 11:00		309779-001
P-55080808	W	Aug-08-08 12:30		309779-002
T-13080808	W	Aug-08-08 16:00		309779-003
TB080808	W	Aug-08-08 00:00		309779-004



# Certificate of Analysis Summary 309779

## URS Corporation-St. Louis, St. Louis, MO



**Project Name: 900 S. Central Avenue**

**Project Id:** Route 111 & Rand Ave Vicinity / 2156197

**Date Received in Lab:** Aug-09-08 10:00 am

**Contact:** Wendy Pennington

**Report Date:** 18-AUG-08

**Project Location:** Roxana, Illinois 62084

**Project Manager:** Debbie Simmons

<i>Analysis Requested</i>	<i>Lab Id:</i>	309779-001	309779-002	309779-003	309779-004
	<i>Field Id:</i>	T-1080808	P-55080808	T-13080808	TB080808
	<i>Depth:</i>				
	<i>Matrix:</i>	WATER	WATER	WATER	WATER
	<i>Sampled:</i>	Aug-08-08 11:00	Aug-08-08 12:30	Aug-08-08 16:00	Aug-08-08 00:00
<b>VOAs by SW-846 8260B</b>	<i>Extracted:</i>	Aug-14-08 13:41	Aug-15-08 15:35	Aug-14-08 13:49	Aug-14-08 13:51
	<i>Analyzed:</i>	Aug-14-08 14:11	Aug-15-08 19:20	Aug-14-08 15:37	Aug-14-08 15:59
	<i>Units/RL:</i>	ug/L RL	ug/L RL	ug/L RL	ug/L RL
Acetone		U 100	U 100	U 100	U 100
Benzene		U 5.00	686 D 50.0	U 5.00	U 5.00
Bromobenzene		U 5.00	U 5.00	U 5.00	U 5.00
Bromochloromethane		U 5.00	U 5.00	U 5.00	U 5.00
Bromodichloromethane		U 5.00	U 5.00	U 5.00	U 5.00
Bromoform		U 5.00	U 5.00	U 5.00	U 5.00
Bromomethane		U 5.00	U 5.00	U 5.00	U 5.00
2-Butanone		U 50.0	U 50.0	U 50.0	U 50.0
MTBE		U 5.00	U 5.00	U 5.00	U 5.00
n-Butylbenzene		U 5.00	11.1 5.00	U 5.00	U 5.00
Sec-Butylbenzene		U 5.00	7.38 5.00	U 5.00	U 5.00
tert-Butylbenzene		U 5.00	U 5.00	U 5.00	U 5.00
Carbon Disulfide		U 50.0	U 50.0	U 50.0	U 50.0
Carbon Tetrachloride		U 5.00	U 5.00	U 5.00	U 5.00
Chlorobenzene		U 5.00	U 5.00	U 5.00	U 5.00
Chloroethane		U 10.0	U 10.0	U 10.0	U 10.0
Chloroform		U 5.00	U 5.00	U 5.00	U 5.00
Chloromethane		U 10.0	U 10.0	U 10.0	U 10.0
2-Chlorotoluene		U 5.00	U 5.00	U 5.00	U 5.00
4-Chlorotoluene		U 5.00	U 5.00	U 5.00	U 5.00
p-Cymene (p-Isopropyltoluene)		U 5.00	4.30 J 5.00	U 5.00	U 5.00
Dibromochloromethane		U 5.00	U 5.00	U 5.00	U 5.00
1,2-Dibromo-3-Chloropropane		U 5.00	U 5.00	U 5.00	U 5.00
1,2-Dibromoethane		U 5.00	U 5.00	U 5.00	U 5.00
Dibromomethane		U 5.00	U 5.00	U 5.00	U 5.00
1,2-Dichlorobenzene		U 5.00	U 5.00	U 5.00	U 5.00
1,3-Dichlorobenzene		U 5.00	U 5.00	U 5.00	U 5.00
1,4-Dichlorobenzene		U 5.00	U 5.00	U 5.00	U 5.00
Dichlorodifluoromethane		U 5.00	U 5.00	U 5.00	U 5.00
1,1-Dichloroethane		U 5.00	U 5.00	U 5.00	U 5.00
1,2-Dichloroethane		U 5.00	U 5.00	U 5.00	U 5.00
1,1-Dichloroethene		U 5.00	U 5.00	U 5.00	U 5.00
cis-1,2-Dichloroethene		U 5.00	U 5.00	U 5.00	U 5.00
trans-1,2-dichloroethene		U 5.00	U 5.00	U 5.00	U 5.00

This analytical report, and the entire data package it represents, has been made for your exclusive and confidential use. The interpretations and results expressed throughout this analytical report represent the best judgment of XENCO Laboratories. XENCO Laboratories assumes no responsibility and makes no warranty to the end use of the data hereby presented. Our liability is limited to the amount invoiced for this work order unless otherwise agreed to in writing.

**Carlos A. Castro, Ph.D., MBA**  
 Managing Director, Texas



# Certificate of Analysis Summary 309779

URS Corporation-St. Louis, St. Louis, MO



**Project Name: 900 S. Central Avenue**

**Project Id:** Route 111 & Rand Ave Vicinity / 2156197

**Date Received in Lab:** Aug-09-08 10:00 am

**Contact:** Wendy Pennington

**Report Date:** 18-AUG-08

**Project Location:** Roxana, Illinois 62084

**Project Manager:** Debbie Simmons

<i>Analysis Requested</i>	<i>Lab Id:</i>	309779-001	309779-002	309779-003	309779-004
	<i>Field Id:</i>	T-1080808	P-55080808	T-13080808	TB080808
	<i>Depth:</i>				
	<i>Matrix:</i>	WATER	WATER	WATER	WATER
	<i>Sampled:</i>	Aug-08-08 11:00	Aug-08-08 12:30	Aug-08-08 16:00	Aug-08-08 00:00
<b>VOAs by SW-846 8260B</b>	<i>Extracted:</i>	Aug-14-08 13:41	Aug-15-08 15:35	Aug-14-08 13:49	Aug-14-08 13:51
	<i>Analyzed:</i>	Aug-14-08 14:11	Aug-15-08 19:20	Aug-14-08 15:37	Aug-14-08 15:59
	<i>Units/RL:</i>	ug/L RL	ug/L RL	ug/L RL	ug/L RL
1,2-Dichloropropane		U 5.00	U 5.00	U 5.00	U 5.00
1,3-Dichloropropane		U 5.00	U 5.00	U 5.00	U 5.00
2,2-Dichloropropane		U 5.00	U 5.00	U 5.00	U 5.00
1,1-Dichloropropene		U 5.00	U 5.00	U 5.00	U 5.00
cis-1,3-Dichloropropene		U 5.00	U 5.00	U 5.00	U 5.00
trans-1,3-dichloropropene		U 5.00	U 5.00	U 5.00	U 5.00
Ethylbenzene		U 5.00	921 D 50.0	U 5.00	U 5.00
Hexachlorobutadiene		U 5.00	U 5.00	U 5.00	U 5.00
2-Hexanone		U 50.0	U 50.0	U 50.0	U 50.0
isopropylbenzene		U 5.00	53.7 5.00	U 5.00	U 5.00
Methylene Chloride		3.14 J 5.00	2.18 J 5.00	2.83 J 5.00	6.96 5.00
4-Methyl-2-Pentanone		U 50.0	U 50.0	U 50.0	U 50.0
Naphthalene		U 10.0	149 D 100	U 10.0	U 10.0
n-Propylbenzene		U 5.00	87.3 5.00	U 5.00	U 5.00
Styrene		U 5.00	U 5.00	U 5.00	U 5.00
1,1,1,2-Tetrachloroethane		U 5.00	U 5.00	U 5.00	U 5.00
1,1,2,2-Tetrachloroethane		U 5.00	U 5.00	U 5.00	U 5.00
Tetrachloroethylene		U 5.00	U 5.00	U 5.00	U 5.00
Toluene		U 5.00	350 D 50.0	U 5.00	U 5.00
1,2,3-Trichlorobenzene		U 5.00	U 5.00	U 5.00	U 5.00
1,2,4-Trichlorobenzene		U 5.00	U 5.00	U 5.00	U 5.00
1,1,1-Trichloroethane		U 5.00	U 5.00	U 5.00	U 5.00
1,1,2-Trichloroethane		U 5.00	U 5.00	U 5.00	U 5.00
Trichloroethene		U 5.00	U 5.00	U 5.00	U 5.00
Trichlorofluoromethane		U 5.00	U 5.00	U 5.00	U 5.00
1,2,3-Trichloropropane		U 5.00	U 5.00	U 5.00	U 5.00
1,2,4-Trimethylbenzene		U 5.00	403 D 50.0	U 5.00	U 5.00
1,3,5-Trimethylbenzene		U 5.00	93.6 5.00	U 5.00	U 5.00
o-Xylene		U 5.00	118 5.00	U 5.00	U 5.00
m,p-Xylenes		U 10.0	1780 D 100	U 10.0	U 10.0
Vinyl Chloride		U 2.00	U 2.00	U 2.00	U 2.00

This analytical report, and the entire data package it represents, has been made for your exclusive and confidential use. The interpretations and results expressed throughout this analytical report represent the best judgment of XENCO Laboratories. XENCO Laboratories assumes no responsibility and makes no warranty to the end use of the data hereby presented. Our liability is limited to the amount invoiced for this work order unless otherwise agreed to in writing.

Since 1990 Houston - Dallas - San Antonio - Austin - Tampa - Miami - Latin America - Atlanta - Corpus Christi

Carlos A. Castro, Ph.D., MBA  
Managing Director, Texas



**XENCO Laboratories**  
**CHRONOLOGY OF HOLDING TIMES**



Analytical Method : VOAs by SW-846 8260B

Client : URS Corporation-St. Louis

Work Order #: 309779

Project ID: Route 111 & Rand Ave Vicini

Field Sample ID	Date Collected	Date Received	Date Extracted	Max Holding Time Extracted (Days)	Time Held Extracted (Days)	Date Analyzed	Max Holding Time Analyzed (Days)	Time Held Analyzed (Days)	Q
T-1080808	Aug. 8, 2008	Aug. 9, 2008				Aug.14, 2008	14	6	P
P-55080808	Aug. 8, 2008	Aug. 9, 2008				Aug.15, 2008	14	7	P
TB080808	Aug. 8, 2008	Aug. 9, 2008				Aug.14, 2008	14	6	P
T-13080808	Aug. 8, 2008	Aug. 9, 2008				Aug.14, 2008	14	6	P

F = These samples were analyzed outside the recommended holding time.

P = Samples analyzed within the recommended holding time.



# Flagging Criteria

- X** In our quality control review of the data a QC deficiency was observed and flagged as noted. MS/MSD recoveries were found to be outside of the laboratory control limits due to possible matrix /chemical interference, or a concentration of target analyte high enough to effect the recovery of the spike concentration. This condition could also effect the relative percent difference in the MS/MSD.
- B** A target analyte or common laboratory contaminant was identified in the method blank. Its presence indicates possible field or laboratory contamination.
- D** The sample(s) were diluted due to targets detected over the highest point of the calibration curve, or due to matrix interference. Dilution factors are included in the final results. The result is from a diluted sample.
- E** The data exceeds the upper calibration limit; therefore, the concentration is reported as estimated.
- F** RPD exceeded lab control limits.
- J** The target analyte was positively identified below the MQL(PQL) and above the SQL(MDL).
- U** Analyte was not detected.
- L** The LCS data for this analytical batch was reported below the laboratory control limits for this analyte. The department supervisor and QA Director reviewed data. The samples were either reanalyzed or flagged as estimated concentrations.
- H** The LCS data for this analytical batch was reported above the laboratory control limits. Supporting QC Data were reviewed by the Department Supervisor and QA Director. Data were determined to be valid for reporting.
- K** Sample analyzed outside of recommended hold time.

\* Outside XENCO'S scope of NELAC Accreditation

***Recipient of the Prestigious Small Business Administration Award of Excellence in 1994.***

*Certified and approved by numerous States and Agencies.*

*A Small Business and Minority Status Company that delivers SERVICE and QUALITY*

Houston - Dallas - San Antonio - Austin - Tampa - Miami - Atlanta - Corpus Christi - Latin America

11381 Meadowglen Lane Suite L Houston, Tx 77082-2647  
 9701 Harry Hines Blvd , Dallas, TX 75220  
 5332 Blackberry Drive, Suite 104, San Antonio, TX 78238  
 2505 N. Falkenburg Rd., Tampa, FL 33619  
 5757 NW 158th St, Miami Lakes, FL 33014  
 6017 Financial Dr., Norcross, GA 30071

Phone	Fax
(281) 589-0692	(281) 589-0695
(214) 902 0300	(214) 351-9139
(210) 509-3334	(210) 509-3335
(813) 620-2000	(813) 620-2033
(305) 823-8500	(305) 823-8555
(770) 449-8800	(770) 449-5477



# Form 2 - Surrogate Recoveries



Project Name: 900 S. Central Avenue

Work Order #: 309779

Project ID: Route 111 & Rand Ave Vicinity / 21561979

Lab Batch #: 731147

Sample: 309779-001 / SMP

Batch: 1 Matrix: Water

Units: mg/L

SURROGATE RECOVERY STUDY					
VOAs by SW-846 8260B Analytes	Amount Found [A]	True Amount [B]	Recovery %R [D]	Control Limits %R	Flags
4-Bromofluorobenzene	0.0467	0.0500	93	86-115	
Dibromofluoromethane	0.0464	0.0500	93	86-118	
1,2-Dichloroethane-D4	0.0518	0.0500	104	80-120	
Toluene-D8	0.0490	0.0500	98	88-110	

Lab Batch #: 731147

Sample: 309779-001 S / MS

Batch: 1 Matrix: Water

Units: mg/L

SURROGATE RECOVERY STUDY					
VOAs by SW-846 8260B Analytes	Amount Found [A]	True Amount [B]	Recovery %R [D]	Control Limits %R	Flags
4-Bromofluorobenzene	0.0475	0.0500	95	86-115	
Dibromofluoromethane	0.0455	0.0500	91	86-118	
1,2-Dichloroethane-D4	0.0480	0.0500	96	80-120	
Toluene-D8	0.0489	0.0500	98	88-110	

Lab Batch #: 731147

Sample: 309779-001 SD / MSD

Batch: 1 Matrix: Water

Units: mg/L

SURROGATE RECOVERY STUDY					
VOAs by SW-846 8260B Analytes	Amount Found [A]	True Amount [B]	Recovery %R [D]	Control Limits %R	Flags
4-Bromofluorobenzene	0.0494	0.0500	99	86-115	
Dibromofluoromethane	0.0449	0.0500	90	86-118	
1,2-Dichloroethane-D4	0.0445	0.0500	89	80-120	
Toluene-D8	0.0473	0.0500	95	88-110	

Lab Batch #: 731147

Sample: 309779-003 / SMP

Batch: 1 Matrix: Water

Units: mg/L

SURROGATE RECOVERY STUDY					
VOAs by SW-846 8260B Analytes	Amount Found [A]	True Amount [B]	Recovery %R [D]	Control Limits %R	Flags
4-Bromofluorobenzene	0.0500	0.0500	100	86-115	
Dibromofluoromethane	0.0409	0.0500	82	86-118	**
1,2-Dichloroethane-D4	0.0477	0.0500	95	80-120	
Toluene-D8	0.0474	0.0500	95	88-110	

\*\* Surrogates outside limits; data and surrogates confirmed by reanalysis

\*\*\* Poor recoveries due to dilution

Surrogate Recovery [D] = 100 \* A / B

All results are based on MDL and validated for QC purposes.



# Form 2 - Surrogate Recoveries

Project Name: 900 S. Central Avenue



Work Order #: 309779

Project ID: Route 111 & Rand Ave Vicinity / 21561979

Lab Batch #: 731147

Sample: 309779-004 / SMP

Batch: 1 Matrix: Water

Units: mg/L

SURROGATE RECOVERY STUDY					
VOAs by SW-846 8260B	Amount Found [A]	True Amount [B]	Recovery %R [D]	Control Limits %R	Flags
Analytes					
4-Bromofluorobenzene	0.0481	0.0500	96	86-115	
Dibromofluoromethane	0.0417	0.0500	83	86-118	**
1,2-Dichloroethane-D4	0.0459	0.0500	92	80-120	
Toluene-D8	0.0480	0.0500	96	88-110	

Lab Batch #: 731147

Sample: 513936-1-BKS / BKS

Batch: 1 Matrix: Water

Units: mg/L

SURROGATE RECOVERY STUDY					
VOAs by SW-846 8260B	Amount Found [A]	True Amount [B]	Recovery %R [D]	Control Limits %R	Flags
Analytes					
4-Bromofluorobenzene	0.0461	0.0500	92	86-115	
Dibromofluoromethane	0.0510	0.0500	102	86-118	
1,2-Dichloroethane-D4	0.0491	0.0500	98	80-120	
Toluene-D8	0.0500	0.0500	100	88-110	

Lab Batch #: 731147

Sample: 513936-1-BLK / BLK

Batch: 1 Matrix: Water

Units: mg/L

SURROGATE RECOVERY STUDY					
VOAs by SW-846 8260B	Amount Found [A]	True Amount [B]	Recovery %R [D]	Control Limits %R	Flags
Analytes					
4-Bromofluorobenzene	0.0478	0.0500	96	86-115	
Dibromofluoromethane	0.0467	0.0500	93	86-118	
1,2-Dichloroethane-D4	0.0506	0.0500	101	80-120	
Toluene-D8	0.0478	0.0500	96	88-110	

Lab Batch #: 731324

Sample: 309779-002 / DL

Batch: 1 Matrix: Water

Units: mg/L

SURROGATE RECOVERY STUDY					
VOAs by SW-846 8260B	Amount Found [A]	True Amount [B]	Recovery %R [D]	Control Limits %R	Flags
Analytes					
4-Bromofluorobenzene	0.0475	0.0500	95	86-115	
Dibromofluoromethane	0.0445	0.0500	89	86-118	
1,2-Dichloroethane-D4	0.0479	0.0500	96	80-120	
Toluene-D8	0.0467	0.0500	93	88-110	

\*\* Surrogates outside limits; data and surrogates confirmed by reanalysis

\*\*\* Poor recoveries due to dilution

Surrogate Recovery [D] = 100 \* A / B

All results are based on MDL and validated for QC purposes.



# Form 2 - Surrogate Recoveries

Project Name: 900 S. Central Avenue



Work Order #: 309779

Project ID: Route 111 & Rand Ave Vicinity / 21561979

Lab Batch #: 731324

Sample: 309779-002 / SMP

Batch: 1 Matrix: Water

Units: mg/L

SURROGATE RECOVERY STUDY					
VOAs by SW-846 8260B Analytes	Amount Found [A]	True Amount [B]	Recovery %R [D]	Control Limits %R	Flags
4-Bromofluorobenzene	0.0485	0.0500	97	86-115	
Dibromofluoromethane	0.0431	0.0500	86	86-118	
1,2-Dichloroethane-D4	0.0432	0.0500	86	80-120	
Toluene-D8	0.0490	0.0500	98	88-110	

Lab Batch #: 731324

Sample: 309970-013 S / MS

Batch: 1 Matrix: Water

Units: mg/L

SURROGATE RECOVERY STUDY					
VOAs by SW-846 8260B Analytes	Amount Found [A]	True Amount [B]	Recovery %R [D]	Control Limits %R	Flags
4-Bromofluorobenzene	0.0489	0.0500	98	86-115	
Dibromofluoromethane	0.0451	0.0500	90	86-118	
1,2-Dichloroethane-D4	0.0449	0.0500	90	80-120	
Toluene-D8	0.0463	0.0500	93	88-110	

Lab Batch #: 731324

Sample: 309970-013 SD / MSD

Batch: 1 Matrix: Water

Units: mg/L

SURROGATE RECOVERY STUDY					
VOAs by SW-846 8260B Analytes	Amount Found [A]	True Amount [B]	Recovery %R [D]	Control Limits %R	Flags
4-Bromofluorobenzene	0.0474	0.0500	95	86-115	
Dibromofluoromethane	0.0434	0.0500	87	86-118	
1,2-Dichloroethane-D4	0.0472	0.0500	94	80-120	
Toluene-D8	0.0457	0.0500	91	88-110	

Lab Batch #: 731324

Sample: 514032-1-BKS / BKS

Batch: 1 Matrix: Water

Units: mg/L

SURROGATE RECOVERY STUDY					
VOAs by SW-846 8260B Analytes	Amount Found [A]	True Amount [B]	Recovery %R [D]	Control Limits %R	Flags
4-Bromofluorobenzene	0.0481	0.0500	96	86-115	
Dibromofluoromethane	0.0485	0.0500	97	86-118	
1,2-Dichloroethane-D4	0.0500	0.0500	100	80-120	
Toluene-D8	0.0475	0.0500	95	88-110	

\*\* Surrogates outside limits; data and surrogates confirmed by reanalysis

\*\*\* Poor recoveries due to dilution

Surrogate Recovery [D] = 100 \* A / B

All results are based on MDL and validated for QC purposes.



# Form 2 - Surrogate Recoveries

Project Name: 900 S. Central Avenue



Work Order #: 309779

Project ID: Route 111 & Rand Ave Vicinity / 21561979

Lab Batch #: 731324

Sample: 514032-1-BLK / BLK

Batch: 1 Matrix: Water

Units: mg/L

## SURROGATE RECOVERY STUDY

VOAs by SW-846 8260B  Analytes	Amount Found [A]	True Amount [B]	Recovery %R [D]	Control Limits %R	Flags
4-Bromofluorobenzene	0.0478	0.0500	96	86-115	
Dibromofluoromethane	0.0451	0.0500	90	86-118	
1,2-Dichloroethane-D4	0.0498	0.0500	100	80-120	
Toluene-D8	0.0455	0.0500	91	88-110	

\*\* Surrogates outside limits; data and surrogates confirmed by reanalysis

\*\*\* Poor recoveries due to dilution

Surrogate Recovery [D] = 100 \* A / B

All results are based on MDL and validated for QC purposes.

**Project Name: 900 S. Central Avenue**

**Work Order #: 309779**

**Project ID: Route 111 & Rand Ave Vicinity / 21561979**

**Lab Batch #: 731147**

**Sample: 513936-1-BKS**

**Matrix: Water**

**Date Analyzed: 08/14/2008**

**Date Prepared: 08/14/2008**

**Analyst: KHM**

**Reporting Units: ug/L**

**Batch #: 1**

**BLANK /BLANK SPIKE RECOVERY STUDY**

<b>VOAs by SW-846 8260B</b>	<b>Blank Result [A]</b>	<b>Spike Added [B]</b>	<b>Blank Spike Result [C]</b>	<b>Blank Spike %R [D]</b>	<b>Control Limits %R</b>	<b>Flags</b>
<b>Analytes</b>						
Acetone	<100	500	323	65	40-160	
Benzene	<5.00	50.0	45.4	91	66-142	
Bromobenzene	<5.00	50.0	51.0	102	75-125	
Bromochloromethane	<5.00	50.0	53.3	107	73-125	
Bromodichloromethane	<5.00	50.0	51.4	103	75-125	
Bromoform	<5.00	50.0	56.0	112	75-125	
Bromomethane	<5.00	50.0	43.3	87	70-130	
2-Butanone	<50.0	500	376	75	60-140	
MTBE	<5.00	50.0	54.8	110	75-125	
n-Butylbenzene	<5.00	50.0	47.0	94	75-125	
Sec-Butylbenzene	<5.00	50.0	49.6	99	75-125	
tert-Butylbenzene	<5.00	50.0	50.6	101	75-125	
Carbon Disulfide	<50.0	500	506	101	60-140	
Carbon Tetrachloride	<5.00	50.0	47.9	96	62-125	
Chlorobenzene	<5.00	50.0	51.9	104	60-133	
Chloroethane	<10.0	50.0	43.4	87	70-130	
Chloroform	<5.00	50.0	47.7	95	74-125	
Chloromethane	<10.0	50.0	51.4	103	70-130	
2-Chlorotoluene	<5.00	50.0	50.7	101	73-125	
4-Chlorotoluene	<5.00	50.0	50.3	101	74-125	
p-Cymene (p-Isopropyltoluene)	<5.00	50.0	51.0	102	75-125	
Dibromochloromethane	<5.00	50.0	52.7	105	73-125	
1,2-Dibromo-3-Chloropropane	<5.00	50.0	48.0	96	59-125	
1,2-Dibromoethane	<5.00	50.0	54.8	110	73-125	
Dibromomethane	<5.00	50.0	50.4	101	69-127	
1,2-Dichlorobenzene	<5.00	50.0	50.8	102	75-125	
1,3-Dichlorobenzene	<5.00	50.0	52.2	104	75-125	
1,4-Dichlorobenzene	<5.00	50.0	49.4	99	75-125	
Dichlorodifluoromethane	<5.00	50.0	55.3	111	70-130	
1,1-Dichloroethane	<5.00	50.0	47.7	95	72-125	
1,2-Dichloroethane	<5.00	50.0	51.2	102	68-127	
1,1-Dichloroethene	<5.00	50.0	54.8	110	59-172	
cis-1,2-Dichloroethene	<5.00	50.0	51.2	102	75-125	

Blank Spike Recovery [D] = 100\*[C]/[B]

All results are based on MDL and validated for QC purposes.

**Project Name: 900 S. Central Avenue**

**Work Order #:** 309779

**Project ID:** Route 111 & Rand Ave Vicinity / 21561979

**Lab Batch #:** 731147

**Sample:** 513936-1-BKS

**Matrix:** Water

**Date Analyzed:** 08/14/2008

**Date Prepared:** 08/14/2008

**Analyst:** KHM

**Reporting Units:** ug/L

**Batch #:** 1

**BLANK /BLANK SPIKE RECOVERY STUDY**

<b>VOAs by SW-846 8260B</b>	<b>Blank Result [A]</b>	<b>Spike Added [B]</b>	<b>Blank Spike Result [C]</b>	<b>Blank Spike %R [D]</b>	<b>Control Limits %R</b>	<b>Flags</b>
<b>Analytes</b>						
trans-1,2-dichloroethene	<5.00	50.0	50.3	101	75-125	
1,2-Dichloropropane	<5.00	50.0	47.5	95	74-125	
1,3-Dichloropropane	<5.00	50.0	49.6	99	75-125	
2,2-Dichloropropane	<5.00	50.0	48.2	96	75-125	
1,1-Dichloropropene	<5.00	50.0	47.0	94	75-125	
cis-1,3-Dichloropropene	<5.00	50.0	51.1	102	74-125	
trans-1,3-dichloropropene	<5.00	50.0	53.4	107	66-125	
Ethylbenzene	<5.00	50.0	51.1	102	75-125	
Hexachlorobutadiene	<5.00	50.0	51.7	103	75-125	
2-Hexanone	<50.0	500	391	78	60-140	
isopropylbenzene	<5.00	50.0	50.6	101	75-125	
Methylene Chloride	<5.00	50.0	49.9	100	75-125	
4-Methyl-2-Pentanone	<50.0	500	481	96	60-140	
Naphthalene	<10.0	50.0	54.7	109	75-125	
n-Propylbenzene	<5.00	50.0	49.7	99	75-125	
Styrene	<5.00	50.0	53.1	106	75-125	
1,1,1,2-Tetrachloroethane	<5.00	50.0	56.6	113	72-125	
1,1,1,2,2-Tetrachloroethane	<5.00	50.0	51.8	104	74-125	
Tetrachloroethylene	<5.00	50.0	54.7	109	71-125	
Toluene	<5.00	50.0	49.7	99	59-139	
1,2,3-Trichlorobenzene	<5.00	50.0	53.9	108	75-137	
1,2,4-Trichlorobenzene	<5.00	50.0	53.5	107	75-135	
1,1,1-Trichloroethane	<5.00	50.0	51.0	102	75-125	
1,1,2-Trichloroethane	<5.00	50.0	51.3	103	75-127	
Trichloroethene	<5.00	50.0	49.5	99	62-137	
Trichlorofluoromethane	<5.00	50.0	51.2	102	67-125	
1,2,3-Trichloropropane	<5.00	50.0	55.3	111	75-125	
1,2,4-Trimethylbenzene	<5.00	50.0	48.3	97	75-125	
1,3,5-Trimethylbenzene	<5.00	50.0	48.7	97	70-125	
o-Xylene	<5.00	50.0	51.2	102	75-125	
m,p-Xylenes	<10.0	100	101	101	75-125	
Vinyl Chloride	<2.00	50.0	41.7	83	75-125	

Blank Spike Recovery [D] = 100\*[C]/[B]

All results are based on MDL and validated for QC purposes.

**Project Name: 900 S. Central Avenue**

**Work Order #:** 309779

**Project ID:** Route 111 & Rand Ave Vicinity / 21561979

**Lab Batch #:** 731324

**Sample:** 514032-1-BKS

**Matrix:** Water

**Date Analyzed:** 08/15/2008

**Date Prepared:** 08/15/2008

**Analyst:** KHM

**Reporting Units:** ug/L

**Batch #:** 1

**BLANK /BLANK SPIKE RECOVERY STUDY**

VOAs by SW-846 8260B  Analytes	Blank Result [A]	Spike Added [B]	Blank Spike Result [C]	Blank Spike %R [D]	Control Limits %R	Flags
Acetone	<100	500	310	62	40-160	
Benzene	<5.00	50.0	49.3	99	66-142	
Bromobenzene	<5.00	50.0	54.2	108	75-125	
Bromochloromethane	<5.00	50.0	54.1	108	73-125	
Bromodichloromethane	<5.00	50.0	52.3	105	75-125	
Bromoform	<5.00	50.0	61.3	123	75-125	
Bromomethane	<5.00	50.0	45.2	90	70-130	
2-Butanone	<50.0	500	372	74	60-140	
MTBE	<5.00	50.0	50.9	102	75-125	
n-Butylbenzene	<5.00	50.0	51.7	103	75-125	
Sec-Butylbenzene	<5.00	50.0	54.8	110	75-125	
tert-Butylbenzene	<5.00	50.0	57.1	114	75-125	
Carbon Disulfide	<50.0	500	455	91	60-140	
Carbon Tetrachloride	<5.00	50.0	51.8	104	62-125	
Chlorobenzene	<5.00	50.0	54.0	108	60-133	
Chloroethane	<10.0	50.0	45.8	92	70-130	
Chloroform	<5.00	50.0	47.8	96	74-125	
Chloromethane	<10.0	50.0	44.8	90	70-130	
2-Chlorotoluene	<5.00	50.0	54.1	108	73-125	
4-Chlorotoluene	<5.00	50.0	51.4	103	74-125	
p-Cymene (p-Isopropyltoluene)	<5.00	50.0	55.8	112	75-125	
Dibromochloromethane	<5.00	50.0	57.1	114	73-125	
1,2-Dibromo-3-Chloropropane	<5.00	50.0	53.7	107	59-125	
1,2-Dibromoethane	<5.00	50.0	57.8	116	73-125	
Dibromomethane	<5.00	50.0	53.5	107	69-127	
1,2-Dichlorobenzene	<5.00	50.0	54.6	109	75-125	
1,3-Dichlorobenzene	<5.00	50.0	53.8	108	75-125	
1,4-Dichlorobenzene	<5.00	50.0	52.2	104	75-125	
Dichlorodifluoromethane	<5.00	50.0	43.7	87	70-130	
1,1-Dichloroethane	<5.00	50.0	48.2	96	72-125	
1,2-Dichloroethane	<5.00	50.0	50.0	100	68-127	
1,1-Dichloroethene	<5.00	50.0	51.7	103	59-172	
cis-1,2-Dichloroethene	<5.00	50.0	49.5	99	75-125	

Blank Spike Recovery [D] = 100\*[C]/[B]  
 All results are based on MDL and validated for QC purposes.

**Project Name: 900 S. Central Avenue**

**Work Order #: 309779**

**Project ID: Route 111 & Rand Ave Vicinity / 21561979**

**Lab Batch #: 731324**

**Sample: 514032-1-BKS**

**Matrix: Water**

**Date Analyzed: 08/15/2008**

**Date Prepared: 08/15/2008**

**Analyst: KHM**

**Reporting Units: ug/L**

**Batch #: 1**

**BLANK /BLANK SPIKE RECOVERY STUDY**

<b>VOAs by SW-846 8260B</b>						
<b>Analytes</b>	<b>Blank Result [A]</b>	<b>Spike Added [B]</b>	<b>Blank Spike Result [C]</b>	<b>Blank Spike %R [D]</b>	<b>Control Limits %R</b>	<b>Flags</b>
trans-1,2-dichloroethene	<5.00	50.0	49.9	100	75-125	
1,2-Dichloropropane	<5.00	50.0	50.8	102	74-125	
1,3-Dichloropropane	<5.00	50.0	53.4	107	75-125	
2,2-Dichloropropane	<5.00	50.0	46.9	94	75-125	
1,1-Dichloropropene	<5.00	50.0	46.5	93	75-125	
cis-1,3-Dichloropropene	<5.00	50.0	53.8	108	74-125	
trans-1,3-dichloropropene	<5.00	50.0	54.5	109	66-125	
Ethylbenzene	<5.00	50.0	52.4	105	75-125	
Hexachlorobutadiene	<5.00	50.0	54.6	109	75-125	
2-Hexanone	<50.0	500	393	79	60-140	
isopropylbenzene	<5.00	50.0	55.9	112	75-125	
Methylene Chloride	<5.00	50.0	46.9	94	75-125	
4-Methyl-2-Pentanone	<50.0	500	523	105	60-140	
Naphthalene	<10.0	50.0	63.9	128	75-125	H
n-Propylbenzene	<5.00	50.0	56.1	112	75-125	
Styrene	<5.00	50.0	55.5	111	75-125	
1,1,1,2-Tetrachloroethane	<5.00	50.0	56.6	113	72-125	
1,1,1,2-Tetrachloroethane	<5.00	50.0	57.3	115	74-125	
Tetrachloroethylene	<5.00	50.0	55.2	110	71-125	
Toluene	<5.00	50.0	51.9	104	59-139	
1,2,3-Trichlorobenzene	<5.00	50.0	59.3	119	75-137	
1,2,4-Trichlorobenzene	<5.00	50.0	56.8	114	75-135	
1,1,1-Trichloroethane	<5.00	50.0	48.0	96	75-125	
1,1,2-Trichloroethane	<5.00	50.0	54.0	108	75-127	
Trichloroethene	<5.00	50.0	50.9	102	62-137	
Trichlorofluoromethane	<5.00	50.0	47.7	95	67-125	
1,2,3-Trichloropropane	<5.00	50.0	54.8	110	75-125	
1,2,4-Trimethylbenzene	<5.00	50.0	54.6	109	75-125	
1,3,5-Trimethylbenzene	<5.00	50.0	54.7	109	70-125	
o-Xylene	<5.00	50.0	54.0	108	75-125	
m,p-Xylenes	<10.0	100	106	106	75-125	
Vinyl Chloride	<2.00	50.0	43.7	87	75-125	

Blank Spike Recovery [D] = 100\*[C]/[B]

All results are based on MDL and validated for QC purposes.



## Form 3 - MS / MSD Recoveries



**Project Name: 900 S. Central Avenue**

Work Order #: 309779

Project ID: Route 111 & Rand Ave Vicinity / 21561979

Lab Batch ID: 731147

QC- Sample ID: 309779-001 S

Batch #: 1 Matrix: Water

Date Analyzed: 08/14/2008

Date Prepared: 08/14/2008

Analyst: KHM

Reporting Units: ug/L

VOAs by SW-846 8260B  Analytes	MATRIX SPIKE / MATRIX SPIKE DUPLICATE RECOVERY STUDY										
	Parent Sample Result [A]	Spike Added [B]	Spiked Sample Result [C]	Spiked Sample %R [D]	Spike Added [E]	Duplicate Spiked Sample Result [F]	Spiked Dup. %R [G]	RPD %	Control Limits %R	Control Limits %RPD	Flag
Acetone	<100	500	211	42	500	204	41	2	40-160	21	
Benzene	<5.00	50.0	44.4	89	50.0	42.3	85	5	66-142	21	
Bromobenzene	<5.00	50.0	48.5	97	50.0	52.0	104	7	75-125	20	
Bromochloromethane	<5.00	50.0	47.5	95	50.0	45.7	91	4	73-125	20	
Bromodichloromethane	<5.00	50.0	48.7	97	50.0	48.1	96	1	75-125	20	
Bromoform	<5.00	50.0	50.2	100	50.0	50.9	102	2	75-125	20	
Bromomethane	<5.00	50.0	42.5	85	50.0	28.3	57	39	70-130	20	XF
2-Butanone	<50.0	500	286	57	500	294	59	3	60-140	20	X
MTBE	<5.00	50.0	46.8	94	50.0	44.1	88	7	75-125	20	
n-Butylbenzene	<5.00	50.0	47.6	95	50.0	45.8	92	3	75-125	20	
Sec-Butylbenzene	<5.00	50.0	49.2	98	50.0	48.9	98	0	75-125	20	
tert-Butylbenzene	<5.00	50.0	50.0	100	50.0	50.7	101	1	75-125	20	
Carbon Disulfide	<50.0	500	471	94	500	422	84	11	60-140	20	
Carbon Tetrachloride	<5.00	50.0	51.2	102	50.0	43.8	88	15	62-125	20	
Chlorobenzene	<5.00	50.0	49.5	99	50.0	49.0	98	1	60-133	21	
Chloroethane	<10.0	50.0	39.5	79	50.0	30.4	61	26	70-130	20	XF
Chloroform	<5.00	50.0	43.2	86	50.0	41.8	84	2	74-125	20	
Chloromethane	<10.0	50.0	44.0	88	50.0	38.5	77	13	70-130	20	
2-Chlorotoluene	<5.00	50.0	48.0	96	50.0	48.1	96	0	73-125	20	
4-Chlorotoluene	<5.00	50.0	49.2	98	50.0	52.3	105	7	74-125	20	
p-Cymene (p-Isopropyltoluene)	<5.00	50.0	50.7	101	50.0	51.6	103	2	75-125	20	
Dibromochloromethane	<5.00	50.0	49.7	99	50.0	47.9	96	3	73-125	20	
1,2-Dibromo-3-Chloropropane	<5.00	50.0	44.7	89	50.0	43.4	87	2	59-125	28	

Matrix Spike Percent Recovery [D] = 100\*(C-A)/B  
 Relative Percent Difference RPD = 200\*(C-F)/(C+F)

Matrix Spike Duplicate Percent Recovery [G] = 100\*(F-A)/E

ND = Not Detected, J = Present Below Reporting Limit, B = Present in Blank, NR = Not Requested, I = Interference, NA = Not Applicable  
 N = See Narrative, EQL = Estimated Quantitation Limit



# Form 3 - MS / MSD Recoveries



**Project Name: 900 S. Central Avenue**

**Work Order # :** 309779

**Project ID:** Route 111 & Rand Ave Vicinity / 21561979

**Lab Batch ID:** 731147

**QC- Sample ID:** 309779-001 S

**Batch #:** 1    **Matrix:** Water

**Date Analyzed:** 08/14/2008

**Date Prepared:** 08/14/2008

**Analyst:** KHM

**Reporting Units:** ug/L

VOAs by SW-846 8260B Analytes	Parent Sample Result [A]	Spike Added [B]	Spiked Sample Result [C]	Spiked Sample %R [D]	Spike Added [E]	Duplicate Spiked Sample Result [F]	Spiked Dup. %R [G]	RPD %	Control Limits %R	Control Limits %RPD	Flag
1,2-Dibromoethane	<5.00	50.0	50.3	101	50.0	50.2	100	1	73-125	20	
Dibromomethane	<5.00	50.0	46.5	93	50.0	46.8	94	1	69-127	23	
1,2-Dichlorobenzene	<5.00	50.0	49.4	99	50.0	48.2	96	3	75-125	20	
1,3-Dichlorobenzene	<5.00	50.0	49.4	99	50.0	52.4	105	6	75-125	20	
1,4-Dichlorobenzene	<5.00	50.0	47.5	95	50.0	48.9	98	3	75-125	20	
Dichlorodifluoromethane	<5.00	50.0	47.1	94	50.0	46.1	92	2	70-130	23	
1,1-Dichloroethane	<5.00	50.0	44.1	88	50.0	40.1	80	10	72-125	20	
1,2-Dichloroethane	<5.00	50.0	44.5	89	50.0	44.6	89	0	68-127	20	
1,1-Dichloroethene	<5.00	50.0	49.0	98	50.0	43.3	87	12	59-172	22	
cis-1,2-Dichloroethene	<5.00	50.0	46.7	93	50.0	43.3	87	7	75-125	20	
trans-1,2-dichloroethene	<5.00	50.0	47.3	95	50.0	42.9	86	10	75-125	20	
1,2-Dichloropropane	<5.00	50.0	45.9	92	50.0	44.9	90	2	74-125	20	
1,3-Dichloropropane	<5.00	50.0	43.6	87	50.0	47.2	94	8	75-125	20	
2,2-Dichloropropane	<5.00	50.0	48.6	97	50.0	41.4	83	16	75-125	20	
1,1-Dichloropropene	<5.00	50.0	41.9	84	50.0	39.8	80	5	75-125	20	
cis-1,3-Dichloropropene	<5.00	50.0	47.5	95	50.0	50.3	101	6	74-125	20	
trans-1,3-dichloropropene	<5.00	50.0	48.7	97	50.0	53.1	106	9	66-125	20	
Ethylbenzene	<5.00	50.0	48.9	98	50.0	47.1	94	4	75-125	20	
Hexachlorobutadiene	<5.00	50.0	54.3	109	50.0	47.3	95	14	75-125	20	
2-Hexanone	<50.0	500	318	64	500	328	66	3	60-140	21	
isopropylbenzene	<5.00	50.0	50.8	102	50.0	46.7	93	9	75-125	20	
Methylene Chloride	3.14	50.0	45.2	84	50.0	42.7	79	6	75-125	35	
4-Methyl-2-Pentanone	<50.0	500	429	86	500	448	90	5	60-140	25	

Matrix Spike Percent Recovery [D] = 100\*(C-A)/B  
Relative Percent Difference RPD = 200\*(C-F)/(C+F)

Matrix Spike Duplicate Percent Recovery [G] = 100\*(F-A)/E

ND = Not Detected, J = Present Below Reporting Limit, B = Present in Blank, NR = Not Requested, I = Interference, NA = Not Applicable  
N = See Narrative, EQL = Estimated Quantitation Limit



# Form 3 - MS / MSD Recoveries



**Project Name: 900 S. Central Avenue**

Work Order # : 309779

Project ID: Route 111 & Rand Ave Vicinity / 21561979

Lab Batch ID: 731147

QC- Sample ID: 309779-001 S

Batch #: 1 Matrix: Water

Date Analyzed: 08/14/2008

Date Prepared: 08/14/2008

Analyst: KHM

Reporting Units: ug/L

<b>VOAs by SW-846 8260B</b>	<b>Parent Sample Result [A]</b>	<b>Spike Added [B]</b>	<b>Spiked Sample Result [C]</b>	<b>Spiked Sample %R [D]</b>	<b>Spike Added [E]</b>	<b>Duplicate Spiked Sample Result [F]</b>	<b>Spiked Dup. %R [G]</b>	<b>RPD %</b>	<b>Control Limits %R</b>	<b>Control Limits %RPD</b>	<b>Flag</b>
<b>Analytes</b>											
Naphthalene	<10.0	50.0	50.8	102	50.0	47.0	94	8	75-125	20	
n-Propylbenzene	<5.00	50.0	48.6	97	50.0	48.8	98	1	75-125	20	
Styrene	<5.00	50.0	49.5	99	50.0	49.0	98	1	75-125	51	
1,1,1,2-Tetrachloroethane	<5.00	50.0	54.9	110	50.0	49.3	99	11	72-125	20	
1,1,2,2-Tetrachloroethane	<5.00	50.0	48.1	96	50.0	44.2	88	9	74-125	31	
Tetrachloroethylene	<5.00	50.0	50.3	101	50.0	52.6	105	4	71-125	20	
Toluene	<5.00	50.0	47.9	96	50.0	46.4	93	3	59-139	21	
1,2,3-Trichlorobenzene	<5.00	50.0	53.1	106	50.0	47.6	95	11	75-137	20	
1,2,4-Trichlorobenzene	<5.00	50.0	52.4	105	50.0	48.0	96	9	75-135	20	
1,1,1-Trichloroethane	<5.00	50.0	47.4	95	50.0	42.9	86	10	75-125	20	
1,1,2-Trichloroethane	<5.00	50.0	47.2	94	50.0	46.3	93	1	75-127	20	
Trichloroethene	<5.00	50.0	48.6	97	50.0	44.6	89	9	62-137	24	
Trichlorofluoromethane	<5.00	50.0	46.3	93	50.0	39.1	78	18	67-125	20	
1,2,3-Trichloropropane	<5.00	50.0	48.6	97	50.0	46.8	94	3	75-125	20	
1,2,4-Trimethylbenzene	<5.00	50.0	48.1	96	50.0	47.8	96	0	75-125	20	
1,3,5-Trimethylbenzene	<5.00	50.0	47.7	95	50.0	48.5	97	2	70-125	20	
o-Xylene	<5.00	50.0	49.3	99	50.0	45.6	91	8	75-125	20	
m,p-Xylenes	<10.0	100	96.6	97	100	94.8	95	2	75-125	20	
Vinyl Chloride	<2.00	50.0	36.7	73	50.0	32.4	65	12	75-125	20	X

Matrix Spike Percent Recovery  $[D] = 100*(C-A)/B$   
 Relative Percent Difference  $RPD = 200*(C-F)/(C+F)$

Matrix Spike Duplicate Percent Recovery  $[G] = 100*(F-A)/E$

ND = Not Detected, J = Present Below Reporting Limit, B = Present in Blank, NR = Not Requested, I = Interference, NA = Not Applicable  
 N = See Narrative, EQL = Estimated Quantitation Limit



# Form 3 - MS / MSD Recoveries



Project Name: 900 S. Central Avenue

Work Order #: 309779

Project ID: Route 111 & Rand Ave Vicinity / 21561979

Lab Batch ID: 731324

QC- Sample ID: 309970-013 S

Batch #: 1 Matrix: Water

Date Analyzed: 08/15/2008

Date Prepared: 08/15/2008

Analyst: KHM

Reporting Units: ug/L

## MATRIX SPIKE / MATRIX SPIKE DUPLICATE RECOVERY STUDY

VOAs by SW-846 8260B Analytes	Parent Sample Result [A]	Spike Added [B]	Spiked Sample Result [C]	Spiked Sample %R [D]	Spike Added [E]	Duplicate Spiked Sample Result [F]	Spiked Dup. %R [G]	RPD %	Control Limits %R	Control Limits %RPD	Flag
Acetone	<100	500	148	30	500	135	27	11	40-160	21	X
Benzene	<5.00	50.0	44.2	88	50.0	44.4	89	1	66-142	21	
Bromobenzene	<5.00	50.0	54.5	109	50.0	52.1	104	5	75-125	20	
Bromochloromethane	<5.00	50.0	45.5	91	50.0	44.7	89	2	73-125	20	
Bromodichloromethane	<5.00	50.0	49.8	100	50.0	48.7	97	3	75-125	20	
Bromoform	<5.00	50.0	59.0	118	50.0	56.0	112	5	75-125	20	
Bromomethane	<5.00	50.0	31.8	64	50.0	32.0	64	0	70-130	20	X
2-Butanone	<50.0	500	228	46	500	214	43	7	60-140	20	X
MTBE	3.04	50.0	47.2	88	50.0	46.6	87	1	75-125	20	
n-Butylbenzene	<5.00	50.0	49.8	100	50.0	48.6	97	3	75-125	20	
Sec-Butylbenzene	<5.00	50.0	53.0	106	50.0	52.3	105	1	75-125	20	
tert-Butylbenzene	<5.00	50.0	55.2	110	50.0	55.4	111	1	75-125	20	
Carbon Disulfide	<50.0	500	366	73	500	359	72	1	60-140	20	
Carbon Tetrachloride	<5.00	50.0	46.6	93	50.0	47.6	95	2	62-125	20	
Chlorobenzene	<5.00	50.0	50.7	101	50.0	50.3	101	0	60-133	21	
Chloroethane	<10.0	50.0	33.7	67	50.0	35.9	72	7	70-130	20	X
Chloroform	<5.00	50.0	42.9	86	50.0	42.5	85	1	74-125	20	
Chloromethane	<10.0	50.0	43.5	87	50.0	40.8	82	6	70-130	20	
2-Chlorotoluene	<5.00	50.0	50.9	102	50.0	50.6	101	1	73-125	20	
4-Chlorotoluene	<5.00	50.0	50.1	100	50.0	49.2	98	2	74-125	20	
p-Cymene (p-Isopropyltoluene)	<5.00	50.0	55.3	111	50.0	54.2	108	3	75-125	20	
Dibromochloromethane	<5.00	50.0	53.8	108	50.0	52.6	105	3	73-125	20	
1,2-Dibromo-3-Chloropropane	<5.00	50.0	46.8	94	50.0	42.5	85	10	59-125	28	

Matrix Spike Percent Recovery  $[D] = 100*(C-A)/B$   
Relative Percent Difference  $RPD = 200*(C-F)/(C+F)$

Matrix Spike Duplicate Percent Recovery  $[G] = 100*(F-A)/E$

ND = Not Detected, J = Present Below Reporting Limit, B = Present in Blank, NR = Not Requested, I = Interference, NA = Not Applicable  
N = See Narrative, EQL = Estimated Quantitation Limit



# Form 3 - MS / MSD Recoveries



Project Name: 900 S. Central Avenue

Work Order #: 309779

Project ID: Route 111 & Rand Ave Vicinity / 21561979

Lab Batch ID: 731324

QC- Sample ID: 309970-013 S

Batch #: 1 Matrix: Water

Date Analyzed: 08/15/2008

Date Prepared: 08/15/2008

Analyst: KHM

Reporting Units: ug/L

VOAs by SW-846 8260B Analytes	Parent Sample Result [A]	Spike Added [B]	Spiked Sample Result [C]	Spiked Sample %R [D]	Spike Added [E]	Duplicate Spiked Sample Result [F]	Spiked Dup. %R [G]	RPD %	Control Limits %R	Control Limits %RPD	Flag
1,2-Dibromoethane	<5.00	50.0	50.6	101	50.0	50.7	101	0	73-125	20	
Dibromomethane	<5.00	50.0	47.2	94	50.0	46.1	92	2	69-127	23	
1,2-Dichlorobenzene	<5.00	50.0	50.7	101	50.0	49.9	100	1	75-125	20	
1,3-Dichlorobenzene	<5.00	50.0	51.7	103	50.0	50.5	101	2	75-125	20	
1,4-Dichlorobenzene	<5.00	50.0	49.2	98	50.0	49.1	98	0	75-125	20	
Dichlorodifluoromethane	<5.00	50.0	29.4	59	50.0	28.5	57	3	70-130	23	X
1,1-Dichloroethane	<5.00	50.0	44.0	88	50.0	42.5	85	3	72-125	20	
1,2-Dichloroethane	<5.00	50.0	43.5	87	50.0	41.2	82	6	68-127	20	
1,1-Dichloroethene	<5.00	50.0	46.6	93	50.0	45.3	91	2	59-172	22	
cis-1,2-Dichloroethene	<5.00	50.0	46.9	94	50.0	44.5	89	5	75-125	20	
trans-1,2-dichloroethene	<5.00	50.0	42.9	86	50.0	42.4	85	1	75-125	20	
1,2-Dichloropropane	<5.00	50.0	48.0	96	50.0	47.2	94	2	74-125	20	
1,3-Dichloropropane	<5.00	50.0	48.5	97	50.0	47.9	96	1	75-125	20	
2,2-Dichloropropane	<5.00	50.0	41.4	83	50.0	40.9	82	1	75-125	20	
1,1-Dichloropropene	<5.00	50.0	43.7	87	50.0	41.7	83	5	75-125	20	
cis-1,3-Dichloropropene	<5.00	50.0	52.3	105	50.0	51.4	103	2	74-125	20	
trans-1,3-dichloropropene	<5.00	50.0	51.4	103	50.0	52.5	105	2	66-125	20	
Ethylbenzene	<5.00	50.0	48.3	97	50.0	47.6	95	2	75-125	20	
Hexachlorobutadiene	<5.00	50.0	51.8	104	50.0	51.9	104	0	75-125	20	
2-Hexanone	<50.0	500	264	53	500	255	51	4	60-140	21	X
isopropylbenzene	<5.00	50.0	50.2	100	50.0	50.5	101	1	75-125	20	
Methylene Chloride	<5.00	50.0	39.4	79	50.0	38.6	77	3	75-125	35	
4-Methyl-2-Pentanone	<50.0	500	427	85	500	420	84	1	60-140	25	

Matrix Spike Percent Recovery [D] = 100\*(C-A)/B  
Relative Percent Difference RPD = 200\*(C-F)/(C+F)

Matrix Spike Duplicate Percent Recovery [G] = 100\*(F-A)/E

ND = Not Detected, J = Present Below Reporting Limit, B = Present in Blank, NR = Not Requested, I = Interference, NA = Not Applicable  
N = See Narrative, EQL = Estimated Quantitation Limit



# Form 3 - MS / MSD Recoveries



Project Name: 900 S. Central Avenue

Work Order #: 309779

Project ID: Route 111 & Rand Ave Vicinity / 21561979

Lab Batch ID: 731324

QC- Sample ID: 309970-013 S

Batch #: 1 Matrix: Water

Date Analyzed: 08/15/2008

Date Prepared: 08/15/2008

Analyst: KHM

Reporting Units: ug/L

VOAs by SW-846 8260B Analytes	Parent Sample Result [A]	Spike Added [B]	Spiked Sample Result [C]	Spiked Sample %R [D]	Spike Added [E]	Duplicate Spiked Sample Result [F]	Spiked Dup. %R [G]	RPD %	Control Limits %R	Control Limits %RPD	Flag
Naphthalene	<10.0	50.0	56.0	112	50.0	54.1	108	4	75-125	20	
n-Propylbenzene	<5.00	50.0	55.0	110	50.0	52.4	105	5	75-125	20	
Styrene	<5.00	50.0	52.4	105	50.0	51.3	103	2	75-125	51	
1,1,1,2-Tetrachloroethane	<5.00	50.0	49.1	98	50.0	52.4	105	7	72-125	20	
1,1,2,2-Tetrachloroethane	<5.00	50.0	47.5	95	50.0	48.5	97	2	74-125	31	
Tetrachloroethylene	<5.00	50.0	52.4	105	50.0	51.8	104	1	71-125	20	
Toluene	<5.00	50.0	47.1	94	50.0	46.2	92	2	59-139	21	
1,2,3-Trichlorobenzene	<5.00	50.0	53.7	107	50.0	52.4	105	2	75-137	20	
1,2,4-Trichlorobenzene	<5.00	50.0	53.3	107	50.0	52.4	105	2	75-135	20	
1,1,1-Trichloroethane	<5.00	50.0	44.2	88	50.0	43.9	88	0	75-125	20	
1,1,2-Trichloroethane	<5.00	50.0	49.1	98	50.0	47.7	95	3	75-127	20	
Trichloroethene	<5.00	50.0	47.9	96	50.0	47.6	95	1	62-137	24	
Trichlorofluoromethane	<5.00	50.0	36.6	73	50.0	35.9	72	1	67-125	20	
1,2,3-Trichloropropane	<5.00	50.0	49.5	99	50.0	47.4	95	4	75-125	20	
1,2,4-Trimethylbenzene	<5.00	50.0	51.7	103	50.0	51.0	102	1	75-125	20	
1,3,5-Trimethylbenzene	<5.00	50.0	52.5	105	50.0	52.2	104	1	70-125	20	
o-Xylene	1.14	50.0	50.4	99	50.0	50.4	99	0	75-125	20	
m,p-Xylenes	<10.0	100	98.9	99	100	98.3	98	1	75-125	20	
Vinyl Chloride	<2.00	50.0	30.1	60	50.0	29.1	58	3	75-125	20	X

Matrix Spike Percent Recovery  $[D] = 100*(C-A)/B$   
Relative Percent Difference  $RPD = 200*(C-F)/(C+F)$

Matrix Spike Duplicate Percent Recovery  $[G] = 100*(F-A)/E$

ND = Not Detected, J = Present Below Reporting Limit, B = Present in Blank, NR = Not Requested, I = Interference, NA = Not Applicable  
N = See Narrative, EQL = Estimated Quantitation Limit

LAB (LOCATION)  
4145 Glenrich Dr., Stafford, TX 77477  
XERO (PHONE) 361-240-4200 FAX 361-240-0860

CALSCIENCE ( )  
 TEST AMERICA ( )  
 SPL ( )  
 OTHER ( )

# Shell Oil Products Chain Of Custody Record



Please Check Appropriate Box:  
 ENV. SERVICES  
 MOTIVA RETAIL  
 MOTIVA SOACH  
 SHELL PIPELINE  
 SHELL RETAIL  
 CONSULTANT  
 LURES  
 OTHER

Print Bill To Contact Name: KEVIN DYER  
 PO # \_\_\_\_\_  
 SAP # \_\_\_\_\_

INCIDENT # (ENV. SERVICES) \_\_\_\_\_  
 CHECK IF NO INCIDENT # APPLIES  
 DATE: 8/8/08  
 PAGE: 1 of 1

CONSULTANT COMPANY: URS CORPORATION - FIELD OFFICE  
 ADDRESS: 1001 HIGHLANDS PLAZA DRIVE WEST - SUITE 300  
 CITY: ST. LOUIS, MISSOURI 63110  
 TELEPHONE: OFF: 314-743-4146 FAX: 314-743-4188  
 CELL: 314-462-4829  
 TURNAROUND TIME (CALENDAR DAYS):  5 DAYS  3 DAYS  2 DAYS  
 DELIVERABLES:  LEVEL 1  LEVEL 2  LEVEL 3  LEVEL 4  OTHER (SPECIFY) \_\_\_\_\_

CONSULTANT PROJECT NAME/NO.: 900 S. CENTRAL AVENUE, ROXANA, ILLINOIS 62084  
 CONSULTANT PROJECT CONTACT (PHONE): WENDY PENNINGTON  
 SAMPLE NAME(S) / DATE: -W. Pennington M. A. / 8/8/08

TEMPERATURE ON RECEIPT °C: \_\_\_\_\_  
 COOLER #1: 2-0°C  
 COOLER #2: \_\_\_\_\_  
 COOLER #3: \_\_\_\_\_

REQUESTED ANALYSIS

SPECIAL INSTRUCTIONS OR NOTES:  
 Please report "U" values.  
 SHELL CONTRACT RATE APPLIES

LAB ID	FIELD SAMPLE IDENTIFICATION	SAMPLING		MATRIX	PRESERVATIVE			NO. OF CONT.	Container PID Readings or Laboratory Notes
		DATE	TIME		HCL	H2SO4	OTHER		
T-1080808		8/8/08	1100	WATER	X			3	
P-55080808		8/8/08	1230	WATER	X			3	
T-13080808		8/8/08	1600	WATER	X			2	
TRB080808				WATER	X			1	
				WATER					
				WATER					
				WATER					
				WATER					
				WATER					
				WATER					

VOC 8260 B

DATE	TIME	PID (ppm)	Container PID Readings or Laboratory Notes
8/8/08	1800		
8/9/08	1000		

Received by (Signature): *[Signature]*  
 Date: 8/8/08  
 Time: 1800

Received by (Signature): *[Signature]*  
 Date: 8/9/08  
 Time: 1000

FED EX



Prelogin/Nonconformance Report- Sample Log-In

Client: UNL

Date/ Time: 8/9/0

Lab ID #: 309779-H

Initials: [Signature]

**Sample Receipt Checklist**

#1	Temperature of container/ cooler?	<input checked="" type="radio"/> Yes	No	N/A	2.0°C
#2	Shipping container in good condition?	<input checked="" type="radio"/> Yes	No	None	
#3	Samples received on ice?	<input checked="" type="radio"/> Yes	No	N/A	Blue/Water
#4	Custody Seals intact on shipping container/ cooler?	<input checked="" type="radio"/> Yes	No	N/A	
#5	Custody Seals intact on sample bottles/ container?	Yes	No	<input checked="" type="radio"/> N/A	
#6	Chain of Custody present?	<input checked="" type="radio"/> Yes	No		
#7	Sample instructions complete of Chain of Custody?	<input checked="" type="radio"/> Yes	No		
#8	Any missing/extra samples?	Yes	<input checked="" type="radio"/> No		
#9	Chain of Custody signed when relinquished/ received?	<input checked="" type="radio"/> Yes	No		
#10	Chain of Custody agrees with sample label(s)?	<input checked="" type="radio"/> Yes	No		
#11	Container label(s) legible and intact?	<input checked="" type="radio"/> Yes	No		
#12	Sample matrix/ properties agree with Chain of Custody?	<input checked="" type="radio"/> Yes	No		
#13	Samples in proper container/ bottle?	<input checked="" type="radio"/> Yes	No		
#14	Samples properly preserved?	<input checked="" type="radio"/> Yes	No	N/A	
#15	Sample container intact?	<input checked="" type="radio"/> Yes	No		
#16	Sufficient sample amount for indicated test(s)?	<input checked="" type="radio"/> Yes	No		
#17	All samples received within sufficient hold time?	<input checked="" type="radio"/> Yes	No		
#18	Subcontract of sample(s)?	Yes	No	N/A	
#19	VOC samples have zero headspace?	<input checked="" type="radio"/> Yes	No	N/A	

**Nonconformance Documentation**

Contact: \_\_\_\_\_ Contacted by: \_\_\_\_\_ Date/ Time: \_\_\_\_\_

Regarding: \_\_\_\_\_

Corrective Action Taken: \_\_\_\_\_

- Check all that Apply:
- Client understands and would like to proceed with analysis
  - Cooling process had begun shortly after sampling event

<u>SOP NUMBER</u>	<u>SOP TITLE</u>
<i>SOP 3</i>	<i>Calibration and Maintenance of Field Instruments</i>
<i>SOP 4</i>	<i>Decontamination</i>
<i>SOP 5</i>	<i>Utility Clearance Procedures</i>
<i>SOP 8</i>	<i>Field Reporting and Documentation</i>
<i>SOP 10</i>	<i>Groundwater Level Measurements</i>
<i>SOP 12</i>	<i>Grouting Procedures</i>
<i>SOP 14</i>	<i>Headspace Soil Screening</i>
<i>SOP 16</i>	<i>IDW Handling</i>
<i>SOP 17</i>	<i>Logging</i>
<i>SOP 18</i>	<i>Low-Flow Groundwater Purging and Sampling</i>
<i>SOP 20</i>	<i>Well Development and Purging</i>
<i>SOP 21</i>	<i>Monitoring Well Installation</i>
<i>SOP 23</i>	<i>Quality Assurance Samples</i>
<i>SOP 24</i>	<i>Sample Classification, Packaging, and Shipping</i>
<i>SOP 25</i>	<i>Sample Containers, Preservation, and Holding Times</i>
<i>SOP 26</i>	<i>Sample Control and Custody Procedures</i>
<i>SOP 28</i>	<i>Soil Sampling</i>
<i>SOP 29</i>	<i>Soil Probe Operation</i>
<i>SOP 33</i>	<i>Water Quality Monitoring</i>
<i>SOP 42</i>	<i>Groundwater Profiling</i>
<i>SOP 44</i>	<i>Soil Vapor Purging and Sampling</i>
<i>SOP 45</i>	<i>No Purge Groundwater Sampling via HydraSleeve</i>

### 1. Objective

This document defines the standard operating procedure for calibration and maintenance of field instruments frequently used during environmental field activities. This Standard Operating Procedure (SOP) gives descriptions of the most common used of these instruments and field procedures necessary to calibrate and maintain these field instruments. Other related SOPs are listed below:

- SOP No. 4 – Decontamination
- SOP No. 8 – Field Reporting and Documentation.

### 2. Equipment

The following equipment is required during field instrument calibration and maintenance activities.

- Latex/Nitrile gloves
- Site logbook
- Field data sheets
- Equipment Calibration Record forms
- Distilled/deionized water
- Decontamination equipment
- Health and Safety Equipment
- Field Instrument Operations Manual
- Calibration gases for Air Monitoring Equipment
- Calibration solutions for Water Monitoring Equipment.

### 3. Type of Field Instruments Commonly used during Environmental Investigations

The following are some of the more commonly used instruments during environmental investigations.

- Photoionization Detector (PID)
- Multi-gas Meter (usually includes Explosimeter, Hydrogen Sulfide detector, Oxygen sensor, and Carbon Monoxide meter)
- RAM

- Groundwater Level Indicator
- Petroleum/Groundwater Interface Probe
- Groundwater pH, Temperature, Conductivity Meter.

#### 4. Maintenance

Maintenance of field instruments should be performed on all field instruments on a regular basis to ensure instruments are in proper working order at all times and to prolong the instruments life. General maintenance such as regular cleaning of the instrument, battery checks and replacement, and ensuring the instrument is handled and stored properly can easily be performed by URS employees. Other maintenance items such as sensor repair, annual calibrations and repair of a malfunctioning piece of equipment should be performed by the instrument manufacturer or licensed dealer and should not be performed by URS employees. Contact the manufacturer to determine where the instrument should be submitted for these maintenance tasks. The vast range of instruments available for use by the environmental professional have an equally vast maintenance regime and therefore maintenance guidelines specified in manual for each piece of equipment should be referred to and followed at all times.

#### 5. Calibration

Due to the vast number of field instruments available, various parameters potentially monitored, and the wide range of functions potentially performed by each instrument, a description of the calibration of every type of instrument available is not feasible. However, a generalized SOP for general types of field equipment calibration is presented and should be followed while performing calibrations of field instruments.

##### Air Monitoring Instruments (PID, Multigas Meters, Hydrogen Sulfide Detectors, etc.)

- Turn the instrument on. The on/off switch may be a toggle switch, knob, or button to be depressed depending on the type and brand of instrument being used.
- Allow the instrument to “warm up” and progress through the startup diagnostic routine.
- Apply the calibration gas (isobutylene, methane, multi-gas mixtures, etc.) to the instrument to get an initial instrument reading.
- Record the initial reading on the proper equipment calibration field form and in the site logbook. Also record the calibration standard and concentration of that standard on the field form and in the logbook.

- If the initial reading is greater than +/-5% of the calibration standard proceed with instrument calibration as specified in the equipment operator's manual. If the initial reading is within this +/- 5% window of the calibration gas standard, the instrument should be considered calibrated and additional calibration is not required at this time. At periodic intervals throughout the day the calibration of the instrument should be check and re-evaluated.
- Apply the calibration gas and proceed as directed in the operator's manual.
- After calibration is complete, record the final calibrated reading on the field equipment calibration forms and in the field logbook. At periodic intervals throughout the day the calibration of the instrument should be check and re-evaluated.

#### Groundwater Parameter Instruments (pH, Temperature, Electrical Conductivity, Turbidity, etc.)

Frequently one instrument will have multiple sensors for measuring various parameters in water. Sensors for temperature, electrical conductivity and turbidity require scheduled calibrations by the equipment manufacturer or authorized service center and should not be performed in the field. The sensor for pH analysis should be calibrated daily in the field prior to use.

- Turn the instrument on. The on/off switch may be a toggle switch, knob, or button to be depressed depending on the type and brand of instrument being used.
- Allow the instrument to "warm up" and progress through the startup diagnostic routine.
- Apply pH 7 and pH 4 buffers solutions as instructed by the instrument prompts or the operator's manual.
- Adjust the reading of the instrument to correlate to the corresponding buffer solution being applied.
- Record reading in the field logbook and on proper field calibration forms.
- Dispose of used buffer solution and reseal buffer solution containers for future use.

#### Water Level Indicator and Petroleum/Water Interface Probe

Field calibration of this instrument is not required. Rather a series of field checks to ensure the instrument is in proper working order will be described.

- Turn the instrument on. The on/off switch is usually a knob located on the side of the reel in which the measuring tape is rolled onto.

- Push the “test” button to ensure that the batteries are in working order. If the batteries are working, an audible tone will be heard and a visible light located on the side of the reel will illuminate.
- Immerse the sensor probe in potable water to ensure the audible tone is heard and visible light illuminates when the electrical circuit is completed when the probe enters the water. Make an observation of where the water level is at on the probe when the circuit is completed. Repeat this step several times to familiarize yourself with this contact point. By performing this step, the chance of submersing the probe to a greater depth than necessary is reduced. Over submersion of the probe will result in a greater amount of the probe and measuring tape to be cleaned and decontaminated prior to collection of another groundwater measurement.
- After collection of every water level measurement, decontaminate all portions of the water level meter or petroleum/water interface probe that came in contact with the groundwater as outlined in SOP No. 4 – Decontamination.

#### 6. *Decontamination*

Small instruments and equipment will be cleaned according to SOP No. 4 – Decontamination and the generalized procedures stated below:

- a. Rinse with potable water to remove the gross contamination
- b. Scrub with brush using Alconox soap (or equivalent) and distilled water solution
- c. Rinse with distilled water.

Decontaminated equipment should be wrapped in aluminum foil or placed in plastic bags between uses and during storage.

## *1. Introduction and Types of Contamination*

This document defines the standard procedure for decontamination. This SOP serves as a supplement to the project Work Plan Addendum and is intended to be used together with several other SOPs. Other related SOPs are listed below:

- SOP No. 8 - Field Reporting and Documentation
- SOP No. 10 - Groundwater Level Measurements
- SOP No. 11 - Groundwater Sampling
- SOP No. 20 – Monitoring Well Development and Purging
- SOP No. 21 - Monitoring Well Installation
- SOP No. 26 - Sample Control and Custody Procedures
- SOP No. 28 - Soil Sampling
- SOP No. 31 - Surface Water Sampling
- SOP No. 32 - Sediment Sampling.

### *Site and/or Sample Cross-Contamination*

The overall objective of multimedia sampling programs is to obtain samples that accurately depict the chemical, physical, and/or biological conditions at the sampling site. Extraneous contaminants can be brought onto the sampling location and/or introduced into the medium of interest during the sampling program (e.g. using sampling equipment that is not properly or fully decontaminated). Trace quantities of contaminants can consequently be captured in a sample and lead to false positive analytical results and, ultimately, to an incorrect assessment of the contaminant conditions associated with the site. Decontamination of sampling equipment (e.g., all non-disposable equipment that will come in direct contact with samples) and field support equipment (e.g., drill rigs, vehicles) is, therefore, required prior to, between, and after uses to ensure that sampling cross-contamination is prevented, and that on-site contaminants are not carried off-site.

## *2. Procedure*

### *2.1 Equipment List*

The following is a list of equipment that may be needed to perform decontamination:

- Brushes
- Wash tubs
- Buckets
- Scrapers, flat bladed
- Hot water - high-pressure sprayer
- Sponges or paper towels
- Alconox detergent (or equivalent)
- Potable tap water
- Laboratory-grade deionized or distilled water
- Garden-type water sprayers.

## 2.2 *Decontamination*

### 2.2.1 *Personnel*

A temporary personnel decontamination line will be set up around each exclusion zone. If contamination is not encountered, a dry decontamination station may be established which consists of discarding of disposable personal protective equipment (PPE).

If real-time monitoring instruments indicate that contamination has been encountered (i.e. action levels are exceeded requiring an upgrade from initial PPE levels), a complete personnel decontamination station will be established.

The temporary decontamination line should provide space to wash and rinse boots, gloves, and all sampling or measuring equipment prior to placing the equipment into a vehicle. A container should be available to dispose of used disposable items such as gloves, tape, or tyvek (if used).

The decontamination procedure for field personnel will include:

1. Glove and boot wash in an Alconox solution
2. Glove and boot rinse
3. Duct tape removal
4. Outer glove removal
5. Coverall removal
6. Respirator removal (if used)
7. Inner glove removal

### 2.2.2 Sampling Equipment

The following steps will be used to decontaminate sampling equipment:

- Personnel will dress in suitable safety equipment to reduce personal exposure as required by the HASP.
- Gross contamination on equipment will be scraped off at the sampling or construction site.
- Equipment that cannot be damaged by water will be placed in a wash tub containing Alconox or low-sudsing nonphosphatic detergent along with potable water and scrubbed with a bristle brush or similar utensil. Equipment will be rinsed with tap water in a second wash tub followed by a deionized or distilled water rinse.
- Equipment that may be damaged by water will be carefully wiped clean using a sponge and detergent water and rinsed with deionized or distilled water. Care will be taken to prevent equipment damage.
- Rinse and detergent water will be replaced with new solutions between borings or sample locations.

Following decontamination, equipment will be placed in a clean area or on clean plastic sheeting to prevent contact with contaminated soil. If the equipment is not used immediately after decontamination, the equipment will be covered or wrapped in plastic sheeting or heavy-duty trash bags to minimize potential contact with contaminants.

### 2.2.3 Drilling and Heavy Equipment

Drilling rigs will be decontaminated at a decontamination station located near a central staging area. The decontamination station may consist of a temporary or permanent structure capable of collecting all decontamination fluids. Mobile decontamination trailers may be used to

decontaminate heavy equipment at each site. The following steps will be used to decontaminate drilling and heavy equipment:

- Personnel will dress in suitable PPE to reduce personal exposure as required by the HSP.
- Equipment showing gross contamination or having caked-on drill cuttings will be scraped with a flat-bladed scraper at the sampling or construction site.
- Equipment that cannot be damaged by water, such as drill rigs, augers, drill bits, and shovels, will be washed with a hot water, high-pressure sprayer then rinsed with potable water. Care will be taken to adequately clean the insides of the hollow-stem augers and backhoe buckets.

Following decontamination, drilling equipment will be placed on the clean drill rig and moved to a clean area. If the equipment is not used immediately, it should be stored in a designated clean area.

#### 2.2.4 Equipment Leaving the Site

Vehicles used for activities in non-contaminated areas shall be cleaned on an as-needed basis, as determined by the Site Safety Officer, using soap and water on the outside and vacuuming the inside. On-site cleaning will be required for very dirty vehicles leaving the area. Construction equipment such as trucks, drilling rigs, backhoes, trailers, etc., will be pressure washed before the equipment is removed from the site to limit exposure of off-site personnel to potential contaminants.

#### 2.2.5 Wastewater

Liquid waste water from decontamination, well development and purging will be containerized and left at the site where it originated, unless otherwise specified.

### 3. Documentation

Sampling personnel will be responsible for documenting the decontamination of sampling and drilling equipment. The documentation will be recorded with waterproof ink in the sampler's field notebook with consecutively numbered pages. The information entered in the field book concerning decontamination should include the following:

- Decontamination personnel
- Date and start and end times
- Decontamination observations

- Weather conditions.

#### 4. *Quality Assurance Requirements*

Equipment rinsate samples of the decontaminated sampling equipment may be taken to verify the effectiveness of the decontamination procedures. The rinsate sampling procedure will include rinsing deionized water through or over a decontaminated sampling tool (such as a split spoon) and collecting the rinsate water into the appropriate sample bottles. The rinsate sampling procedure, including the sample number, will be recorded in the field notebook.

This document defines the standard procedure for subsurface utility clearance. This procedure provides descriptions of equipment and procedures necessary to properly clear utilities prior to beginning subsurface field activities.

This document also defines the procedure for contacting the applicable “one-call” service for locating underground utilities. One-call is a public service provided by individual states as a single point of contact for requesting a utility locate from a majority of underground utilities. This service is primarily for locating utilities on public properties and right-of ways.

### 1. *Equipment*

Equipment used during utility clearance procedures:

- Project map
- Known utility map
- Marking paint
- Stakes or flags
- Permanent marker
- Measuring tape and/or wheel
- Other related field paperwork, as needed.

### 2. *Location marking*

Prior to utility clearance, locations to be drilled or excavated should be marked by field personnel scheduled to complete the work. Per one-call guidelines excavation areas should be marked either a) with stakes or flags with the necessary radius to be cleared marked on the stake or flag or b) with white marking paint (black paint may be substituted when necessary). When using paint, the extent of the area to be cleared should be marked.

When marking locations, initial adjustments to locations should be made based on visible utilities such as overhead power lines, sewers and other utility corridors. As a general rule drill rig masts and excavating equipment must stay at least 10 feet away from overhead utilities. Depending on the voltage of the overhead lines a greater distance may be necessary.

### 3. *One-call*

The purpose of the one-call system is to alert member utility companies to a planned drilling or excavating project. The one-call system will inform the person making the utility call which

member companies will be notified. Additional contacts may be necessary if suspected utility providers in the area of the proposed work are not members of the public one-call system. Individual states have their own one-call number or the national one-call number, 811, may be used. (e.g., Missouri: 1-800-DIG-RITE (344-7483), Illinois: 1-800-892-0123) Some states require the subcontractor actually performing the drilling or excavating to make the initial call (e.g., Illinois).

Once a one-call notification has been placed the utility companies have 48-hours to respond. The time does not include weekends or observed holidays. Once a one-call has been placed work should be ready to start within 10 working days. Once work has begun, renewal of utility locates is determined by an individual state's regulations.

A joint meet may also be requested if the area of the proposed work is large and/or complicated. Member utilities must be given 48-hours prior to the joint meet to schedule a representative to attend. Following the joint meet, an additional 48-hours must be allowed for the utility companies to mark their utilities.

The following information should be provided when making a one-call:

- Identification of who is conducting the work as well as any subcontractor such as a drilling or excavating firm. The contact information for the person responsible along with a phone number where they can be easily reached is a minimum.
- Type of work being conducted (e.g. drilling or excavating).
- Location of work being conducted described as best as possible. Addresses in conjunction with relation to buildings when possible should be used. Other forms of locating include distances and directions from intersections.
- Whether or not a joint meet is required.
- The time frame expected for work to begin.

The following information should be recorded and kept available after the one-call has been made:

- Ticket serial number
- Utilities one-call will notify
- Time and location of joint meet (if applicable)
- Time and date by which utilities are to be cleared

- Log of utilities which have been cleared, either from markings on ground at the location or locator calling to confirm.

Industrial facilities often are responsible for utility locates on their own property and will not be covered by a one-call. Field personnel should coordinate with their contact at such a facility in order to check for known utilities under control or the facility and for any additional clearance efforts which may be required.

When possible, identify the size of underground utilities being marked. The general rule is that the accuracy of marking, from the center of the utility, is the width of the utility plus 1.5-feet. Certain utility companies may require a greater distance from their lines.

The following are the colors from the uniform color code and marking guidelines:

- White (or Black) – Proposed excavations
- Pink – Temporary survey markings
- Red – Electric power lines, cables, conduit and lighting cables
- Yellow – Gas, oil, steam, petroleum or gaseous materials
- Orange – Communication, alarm or signal lines, cables or conduit
- Blue – Potable water
- Purple – Reclaimed water, irrigation and slurry lines
- Green – Sewers and drain lines

These colors shall be used by both the company requesting the utility locate and the member companies marking underground utilities.

#### 4. *Secondary utility clearance*

Secondary utility clearance involves using an air knife, a hand auger, a post-hole digger and/or a shovel to check for utilities prior to beginning the excavation or boring. Some clients/sites require secondary utility clearance as an additional precaution to minimize risk of encountering either active or abandoned buried utilities.

##### *Air Knife*

Air Knife operations involve air/water jetting combined with a high suction vacuum to create a boring or trench of specified dimensions. Single point borings need to have the hole cleared to

below the depth of known utilities in the area and to a diameter 3-inches greater than the diameter of the tools penetrating the ground surface. As an alternative, a “V-trench” or a triangle configuration of air-knife holes can also be used to clear a location. If the air-knife is to be completed in a triangle formation, the air knife holes should be completed in sets of three in as tight a triangle as the boring size will allow, with the center of the boring to be completed at the center of the triangle. Whichever method is selected, the air knife boring(s) must be located so that the absence of underground utilities can be confirmed. Once the location is confirmed as being clear, the air knife hole(s) or trench should be backfilled with an inert material, such as silica sand or flowable fill.

#### Hand Auger

Due to access, availability or cost, air knifing may not be an option. If this is the case, hand augers may be used to clear a location. Due to the size of the hand auger bucket, multiple hand auger holes may be necessary to clear a location for a single boring. If multiple hand augers are necessary, the best option is to complete hand auger holes in sets of three in as tight a triangle as the boring size will allow, with the center of the boring to be completed at the center of the triangle. The same depth requirement for clearance applies to hand auger holes as it does for air knifing. Once the location is confirmed as being clear, the hand auger hole(s) should be backfilled with an inert material, such as silica sand or flowable fill.

#### Post-hole digger / Hand Shovel

As a last choice, conventional means such as a post-hole digger or hand shovel may be used to clear a location. This option is generally best only when any known utilities are very shallow or the surface material is extremely coarse (large gravels and rocks). Hand shovels and post-hole diggers have a higher chance of damaging weaker utilities, so caution should be taken when used. If deeper clearance than a foot or two is necessary, either an air knife or hand auger should be used for utility clearance. Other procedures/protocols mentioned above still apply.

This document defines the standard procedure for field reporting and documentation. This procedure provides descriptions of equipment and field procedures necessary to properly document field activities.

### *1. Equipment*

Equipment used during field reporting and documentation:

- Calculator
- Bound field logbook
- Waterproof pen and permanent marker
- Well completion information form (if necessary)
- Groundwater sampling form (if necessary)
- Boring log (if necessary)
- Other related field paperwork, as needed.

### *2. Field Reporting and Documentation*

Documentation of observations and data acquired in the field will provide information on the acquisition of samples and also provide a permanent record of field activities. The observations and data will be recorded using pens with permanent waterproof ink in a permanently bound weatherproof field logbook.

Field investigation situations vary widely. No set of general rules can anticipate all information that must be entered in a logbook for a particular site. A site-specific logging procedure will be developed to include sufficient information so that the sampling activity can be reconstructed without relying on the memory of field personnel. The logbooks will be kept in the field team member's possession or in a secure place during the investigation.

Each project should have a dedicated logbook. The project leader's name, the sample team leader's name (if appropriate), the project name and location, and the project number should be entered on the inside of the front cover of the logbook. It is recommended that each page in the logbook shall be numbered and dated. The entries should be legible and contain accurate and inclusive documentation of an individual's project activities. At the end of the all entries for each day, or at the end of a particular event, if appropriate, the investigator shall draw a diagonal line and initial and date indicating the conclusion of the entry. Since field records are the basis for later written reports, language should be objective, factual, and free of personal feelings or other terminology which might prove inappropriate. Once completed, these field logbooks

become accountable documents and must be maintained as part of the official project files. All aspects of sample collection and handling, as well as visual observations, shall be documented in the logbooks.

The information in the field book will include the following as a minimum.

- Personnel present
- Level of PPE used during sampling
- Weather conditions
- Names and responsibilities of field crew members
- Names and title of any site visitors
- Field analytical equipment, and equipment utilized to make physical measurements shall be identified
- Sample collection equipment (where appropriate)
- Calibration results of field equipment
- Location of Sample
- Description of samples (matrix sampled)
- Results of any field measurements, such as depth to water, pH, temperature, and conductivity
- Sample depth (if applicable)
- Date and time of sample collection
- Sample identification code including QC and QA identification
- Number and volume of samples
- Sampling methods or reference to the appropriate SOP
- Sample handling, including filtration and preservation, as appropriate for separate sample aliquots
- Analytes of interest
- Information concerning sampling changes, scheduling modifications, and change orders
- Field observations

- Summary of daily tasks
- Signature and date by personnel responsible for observations
- Problems identified with equipment or aspects of the project.

Changes or deletions in the field book should be lined out with a single strike mark, initialed, and remain legible. Sufficient information should be recorded to allow the sampling event to be reconstructed without relying on the sampler's memory.

Each page in the field books will be signed by the person making the entry at the end of the day, as well as on the bottom of each page. Anyone making entries in another person's field book will sign and date those entries.

### 3. Document Control

Document control refers to the maintenance of inspection and investigation project files. All information below shall be kept in project files. Investigators may keep copies of reports in their personal files, however, all official and original documents relating to inspections and investigations shall be placed in the official project files. The following documents shall be placed in the project file, if applicable:

- Chain-of-Custody Records and bound field logbooks
- Records obtained during the investigation
- Complete copy of the analytical data and memorandums transmitting analytical data
- Official correspondence received or transmitted, including records of telephone calls
- Photographs and negatives associated with the project
- One copy of the final report and transmittal memorandum
- Relevant documents related to the original investigation/inspection or follow-up activities related to the investigation/inspection.

Inappropriate personal observations and irrelevant information should not be placed in the official project files. At the conclusion of the project, the project leader shall review the file to ensure that it is complete.

### 1. Objective

This document defines the standard procedure for measuring water levels in wells. This SOP serves as a supplement to the project Work Plan and is intended to be used together with other SOPs. Other related SOPs are listed below:

- SOP No. 4 – Decontamination
- SOP No. 8 – Field Reporting and Documentation
- SOP No. 11 – Groundwater Sampling

### 2. Equipment

The following equipment is required:

- Water Level probe with 0.01-foot increments;
- Well keys;
- Organic vapor monitor;
- Latex/Nitrile gloves;
- Site logbook;
- Field data sheets;
- Spray Bottle
- Distilled/deionized water;
- Appropriate health and safety equipment;
- Permanent ink pen; and
- Decontamination equipment.

### 3. Groundwater Level Measurement Procedures

This section provides step-by-step procedures for collecting groundwater monitoring well fluid level measurements. Observations made during the fluid level measurement should be recorded in the field notebook in accordance with the procedures defined in SOP No. 8 on field reporting and documentation.

Appropriate health and safety equipment, as described in the HSP should be worn during well opening, water level measurement, and decontamination. The following procedures will be completed when measuring water levels:

- The water level probe shall be decontaminated prior to use in each monitoring well. Decontamination procedures are discussed in SOP No. 4.
- The well will be approached from upwind, the well cap unlocked and removed, and the air quality monitored in the casing and breathing zone with an FID or PID. Air quality measurements will be recorded in the field notebook.
- Observations regarding the condition of the well, including the well pad, and surface or protective casing, will be documented in the field notebook.
- Put on a new, unused pair of disposable latex or nitrile gloves.
- An electric water level or NAPL interface probe will be used to measure the depth to water from the top-of-casing reference point (either PVC or steel monitoring well casing) and/or check for NAPLs in the water column, where applicable. Record the depth of water and/or NAPLs, as applicable. This procedure will also be used to measure the depth of the well. Measurements will be made to the nearest 0.01 feet.
- The static water level, the total depth of the well, and the depth of NAPL (if applicable), shall be measured with the probe, recorded on the water level data sheet, and then immediately rechecked before the probe is removed from the well.
- All columns of field data sheets shall be completed, including time of measurement. An example water level data sheet is attached to this SOP. If measurements are taken over a several-day period, the date of each measurement should be clearly indicated on the form.
- Care shall be taken to verify the readings during each water level measurement period. Any significant changes in water level will be noted by comparing the most recent measurement with past measurements.
- After any measurement is taken, the water level probe shall be decontaminated as described in SOP No. 4.
- Place disposable equipment into a plastic garbage bag for disposal.

#### 4. Documentation

The water level data sheet attached to this SOP shall be completed during each measuring event. Field data sheets will include field personnel, date, time, well number, total well depth, water level, static water elevation, and comments. A field notebook will also be kept during water level measurement activities describing decontamination procedures, calibration procedures, monitoring procedures, and other observations during water level measurement. Both the data

sheets and notebook shall be filled out using legible handwriting, and shall be signed and dated by the person completing the page.

The measured depth to water, in feet below the measuring point, will be subtracted from the measuring point elevation to determine the elevation of the static water level. The resulting elevation shall be checked in the field to see that it is reasonable and that the subtraction was performed correctly. If there is a discrepancy, the water level shall be measured again.

## Water Level Record

Job No.: \_\_\_\_\_

Project/Event: \_\_\_\_\_

Client: \_\_\_\_\_

Date: \_\_\_\_\_

Location: \_\_\_\_\_

Personnel: \_\_\_\_\_

Well No.	Time	Depth to Water (ft btoc)	Depth to Product (ft btoc)	Depth to Bottom (ft btoc)	All Bolts Present	Lock Present	Working Cap Present	Pad Condition	Comments

G = Pad in good condition  
 BR = Cracked and Broken  
 NP = No visible pad present

### 1. Summary

The purpose of this Standard Operating Procedure (SOP) is to define the procedures and necessary equipment for the grouting of borings following their completion. If a monitoring well or piezometer is to be installed in the boring refer to the procedure outlined in SOP 21. Other related SOPs are listed below:

- SOP No. 4 – Decontamination
- SOP No. 8 – Field Reporting and Documentation

### 2. Equipment

This section details the required equipment for the drilling and installation of groundwater monitoring wells.

The following is an equipment list typical for well drilling and installation:

- Portland Type I or II Cement
- Powdered bentonite
- Potable water
- Appropriate health and safety equipment as specified in the Health and Safety Plan (HSP)
- Log book and/or boring log sheets
- Drums or other suitable container for mixing of grout

### 3. Procedures

A standard mixture of cement-bentonite grout will consist of the following ratio:

- 1 (94 lb) sack of Portland cement,
- Powdered bentonite (as permitted by state regulations), and
- 7 to 15 gallons of potable water.

A standard mixture of bentonite grout will consist of the following:

- Powdered bentonite (as permitted by state regulations), and
- 7 to 15 gallons of potable water.

The grouting procedures for either type of grout consist of the following:

1. Mix the bentonite and water first to a creamy consistency.

2. Slowly add the Portland Cement (if used). The amount of bentonite or water can be varied to control the consistency and pumpability of the mix.
3. Pump the mixture through tremie pipe or drill rods placed to the bottom of the boring to displace any water or drilling fluids.
4. Withdraw rods or piping when grout has reached surface.
5. Repeat steps 1 – 4 as augers/drill pipe are removed.
6. Grout the remaining open boring to the surface after the augers are removed. The grout will be tremied into the borehole until it is completely filled.
7. After the grout sets for 24 hours it will be checked for settlement. If necessary, additional grout will be added to top off.
8. Add surface seal (asphalt or concrete) as necessary.

#### 4. Documentation

Observations and data acquired in the field during drilling will be recorded to provide a permanent record. A boring log will be completed for each boring according to the procedures outlined in SOP No. 17 – Logging.

Additional documentation will be written in the field book according to SOP No. 8 – Field Reporting and Documentation and will include the following:

- Date
- Time
- Personnel
- Weather
- Subcontractors
- Health and Safety monitoring equipment and readings
- Grout, sand, and bentonite volume calculations prior to well installation
- The quantity and composition of the grout
- Start and completion dates
- Discussion of all procedures and any problems encountered during drilling.

### 1. Objective

Volatile Organic Compound (VOC) field headspace screenings will be performed on selected soil samples to obtain preliminary estimates of VOC concentrations. This qualitative data will be used as criteria in selecting soil samples from locations where collection depths have not been predetermined.

### 2. Equipment

The following equipment is required.

- Quart-sized Zip-Loc bag or equivalent
- Photoionization detector (PID)
- Permanent Marker
- Watch.

### 3. Procedure

The following general procedure is followed:

1. Obtain approximately 1/2 qt of soil and place in clean 1 qt Zip-Loc bag. Immediately seal the Zip-Loc bag. Record the boring location and sample depth on the bag.
2. Break soil into about 1 in. sized particles by squeezing the bag, taking care not to compromise the seal.
3. Place sample in a shaded location where it can be left undisturbed for a minimum of 5 minutes. If the temperature is less than 35° F place the sample bag in a heated vehicle or building.
4. Measure ambient air background VOC concentrations.
5. After at least 5 minutes has elapsed, obtain PID reading from bag headspace by opening a space in the bag seal just large enough to allow the PID probe to enter unobstructed. Continue monitoring until PID readings drop to background concentrations.
6. Record highest PID reading measured.
7. Archive or dispose of soil per site field sampling plan.

## 1. Objective

This document defines the standard operating procedure for IDW handling. Other SOPs providing additional related guidance are listed below:

- SOP No. 4 – Decontamination
- SOP No. 8 – Field Reporting and Documentation.

A variety of IDW related activities may require unearthing, moving, lifting, over packing, or sampling drums. Such activities are inherently hazardous and will always require special health and safety precautions. Drum handling presents numerous serious physical hazards including back injury, crushing, bruising, laceration, and severe trauma from mishandling. Drum contents may represent a fire or explosion hazard or may consist of shock-sensitive or pyrophoric materials. Drum contents may be pressurized or be acutely toxic. Contents may be corrosive or irritating or have other toxic effects. Drum handling may, therefore, represent both physical and chemical hazards.

## 2. Equipment

Equipment used during field reporting and documentation:

- Bound field logbook;
- Waterproof pen and permanent marker;
- Paint pen (appropriate color to be seen on 55-gallon drum);
- Labels for IDW Container;
- Other related field paperwork, as needed;
- Disposable latex or nitrile gloves;
- Assorted tools (knife, screwdriver, crescent wrench, (15/16") socket and drive, non-sparking bung wrench, etc.)

## 3. IDW Handling

- A. Prior to work commencing, identify staging area for IDW containers.
- B. If using 55-gallon drums at individual locations, be sure to stage drums neatly, out of normal traffic patterns, and in such a manor as they can be easily moved for transport to a central staging area or for removal from site.
- C. Containers of IDW must be clearly marked with the following information:
  - Date(s) of Accumulation;
  - Project / Client identification;

- Location (area of site, boring, well, SWMU, etc.)
  - Type of materiel contained within (soil, water, PPE, etc.)
  - Specific potential contamination streams (PCBs, Dioxins, etc.) – if applicable
- D. Avoid filling IDW drums more than three-fourths full in order to facilitate transport to the designated staging area or removal from the site.
- E. IDW containers must be properly closed and labeled as stated above prior to leaving a location. Record in a field logbook the number of IDW containers left at a location.
- F. For characterization of soil from IDW containers refer to SOP 28 and 38. For characterization of water from IDW containers refer to SOP 11. Following collection, place all samples on ice inside a cooler immediately. Each sample should be identified with the Sample ID, location, analysis number, preservatives, date and time of sampling event, and sampler. The sample time and constituents to be analyzed for should be recorded in the logbook and on the groundwater sampling form. Chain-of-custody procedures should be started. Sample equipment should be decontaminated.
- G. Spills or leaks may occur during drum movement and handling. Absorbent materials (clay, oil-dry, etc.) should be readily available in sufficient quantity to absorb spilled or leaked material. Where large spills could occur, a containment berm should be constructed around the area. A special pad for drum handling (concrete, HDPE, etc.) with containment berms may be required for certain types of work. Spill control should be performed by appropriately trained personnel wearing adequate personal protective equipment (PPE). A Spill Plan should be part of the Site Health and Safety Plan (HSP).

### 1. Objective

This document defines the standard procedure for logging of soil and rock samples both for environmental and geotechnical characterization purposes. This procedure provides descriptions of equipment and field procedures necessary to log soil and rock samples. Other related SOPs are listed below:

- SOP No. 8 – Field Reporting and Documentation.
- SOP No. 28 – Soil Sampling.

### 2. Equipment

The following equipment is typically used during soil and rock sample logging:

- USCS Chart
- Boring logs
- Tape measure
- Tore Vain
- Pocket Penetrometer
- Field data sheets/bound field logbook
- Waterproof ink.

### 3. Sample Descriptions

This section provides an approach for describing (logging) soil samples in the field. General observations made before, during, and after field activities should be recorded in a bound field logbook in accordance with the procedures defined in SOP No. 8 on field reporting and documentation:

#### Soil

The soil's description should include as a minimum:

- Apparent consistency (for fine-grained soils) or density (for coarse-grained soil) adjective
- Water content condition adjective
- Color description
- Minor soil type name with “y” added (if  $\geq 30$  percent)

- Descriptive adjective for main soil type
  - Particle-size distribution adjective for gravel and sand
  - Plasticity adjective and soil texture (silty or clayey) for inorganic and organic silts or clays
- Main soil type's name (all capital letters)
- Descriptive adjective, some or trace, for minor soil type if  $\leq 30$  percent
- Minor soil type(s)
- Inclusions
- The Unified Soil Classification System (USCS) Group Name and Symbol appropriate for the soil type in accordance with ASTM D 2487, with few exceptions, and (symbol in parenthesis)
- Geologic name, if known (in parenthesis or in notes column).

The various elements of the soil's description should be stated in the order listed above.

Examples:

Fine-grained soils	Soft, wet, gray, high plasticity CLAY, trace f. sand – Fat CLAY (CH); (Alluvium)
Coarse-grained soils	Dense, moist, brown, silty m-f SAND, trace f. gravel to c. sand – Silty SAND (SM); (Alluvium)

When changes occur within the same soil layer, such as change in apparent density, then this is indicated by means of a bent arrow, point downward ( $\nabla$ ) and a description of the change. Note that only those aspects of the soil description that are different from the description of the overlying soil are mentioned. Note also that the depth at which some characteristic is no longer present must be noted.

#### *Apparent Consistency and Density*

Consistency and density descriptive terms are related to blow count resistance using a 2-inch OD, 24-inch long split barrel sampler and standard penetration tests (a 140-pound hammer dropped 30-inches) (ASTM D 1586-84). Use the values and descriptions in the table presented below to determine the consistency and density.

### Consistency & Density

Cohesive Clays (clays & silts)		Non-cohesive Granular Soils (sands & gravels)	
0-2	Very soft	0-4	Very loose
3-4	Soft	4-10	Loose
5-8	Medium stiff	11-30	Medium dense
9-15	Stiff	31-50	Dense
16-30	Very stiff	>50	Very dense
>30	Hard		

A blow count of >50 for a 12-inch interval constitutes spoon refusal and the sample should be terminated at that time.

The strength of the soil can be determined without blow counts using the following guide:

- H     Hard Soil – Brittle or tough, may be broken in the hand with difficulty. Can be peeled with a pocketknife.
- VST    Very Stiff – Soil can barely be imprinted by pressure from the fingers or indented by thumbnail.
- ST     Stiff – Soil can be imprinted with considerable pressure from fingers or indented by thumbnail.
- M     Medium Stiff – Soil can be imprinted easily with fingers; remolded by strong finger pressure.
- So     Soft – Soil can be pinched in two between the thumb and forefinger; remolded by light finger pressure.
- Vso    Very Soft – Soil exudes between fingers when squeezed; specimen (height = 2 x diameter) sags under its own weight.

#### Water Content

The amount of water present in the soil sample or its water content adjective should be described as dry, moist, or wet as follows:

**Descriptors for Water Content (moisture)**

<b>Description</b>	<b>Condition</b>
Dry	No sign of water and soil is dry to the touch
Moist	Signs of water and soil is relatively dry to the touch
Wet	Signs of water and the soil definitely wet to the touch; granular soil exhibits some free water when densified

The descriptor “damp” should not be used (use “moist”). The descriptor “saturated” should not be used (use “wet”).

*Color*

The colors should be assigned consistent with a Munsell Color Chart and should be described when the sample is first retrieved at the soil’s as-sampled water content (the color will change with water content). A Munsell Color Chart is provided as Appendix A. When the soil is marked with spots of color, the term mottled can be applied with the following descriptors:

**Descriptors for Mottling**

<b>Abundance</b>	<b>Size</b>	<b>Contract</b>
f: few (<2%)	fine (<5 mm)	faint
c: common (2%-20%)	medium (5-15 mm)	distinct
m: many (>20%)	coarse (>15 mm)	prominent

Soils with a homogeneous texture but having color patterns, which change and are not considered mottled, can be described as streaked.

Soil Types

The constituent parts of a given soil type are defined on the basis of texture in accordance with particle-size designators separating the soil into coarse-grained, fine-grained, and highly organic designations.

*Coarse-grained (gravel and sand)*

Soils with more than 50% of the particles larger than No. 200 sieve (0.074 mm). The soil components are described on the basis of particle size as follows:

**Grade Limits and Grade Standards**

<b>Grade Names</b>	
<b>Name</b>	<b>Grain Size</b>
Sand	
fine	#200 to #40 sieve
medium	#40 to #10 sieve
coarse	#10 to #4 sieve
Gravel	
fine	#4 sieve to ¾-inch
coarse	¾-inch to 3-inches
Cobbles	3-inches to 12-inches
Boulders	>12-inches

The particle-size distribution is identified as well graded or poorly graded. Well-graded coarse-grained soil contains a good representation of all particle sizes from largest to smallest, with ≤12 percent fines. Poorly graded coarse-grained soil is uniformly graded with most particles about the same size or lacking one or more intermediate sizes, with ≤12 percent fines. A table of USC symbols and names for coarse-grained soils is presented below.

**USCS Symbols and Names for Coarse-grained Soils**

<b>USCS Symbol</b>	<b>Typical Names</b>
GW	Well graded gravels, gravel-sand mixtures, little or no fines
GP	Poorly graded gravels, gravel-sand mixtures, little or no fines
GM	Silty gravels, gravel-sand-silt mixtures
GC	Clayey gravels, gravel-sand-clay mixtures
SW	Well graded sands, gravelly sands, little or no fines

### USCS Symbols and Names for Coarse-grained Soils

USCS Symbol	Typical Names
SP	Poorly graded sands, gravelly sands, little or no fines
SM	Silty sand, sand-silt mixtures
SC	Clayey sands, sand-clay mixtures

The following field identification tests can be used to estimate the grain size distribution of coarse-grained soils:

Feel and Smear Tests – A pinch of soil is handled lightly between the thumb and fingers to obtain an impression of the grittiness or of the softness of the constituent particles. Thereafter, a pinch of soil is smeared with considerable pressure between the thumb and forefinger to determine the degrees of roughness and grittiness, or the softness and smoothness of the soil.

<u>Coarse- to medium-grained sand:</u>	Typically exhibits a very harsh and gritty feel and smear.
<u>Coarse- to fine-grained sand:</u>	Has a less harsh feel, but exhibits a very gritty smear.
<u>Medium- to fine-grained sand:</u>	Exhibits a less gritty feel and smear which becomes softer and less gritty with an increase in the fine sand fraction.
<u>Fine-grained sand:</u>	Exhibits a relatively soft feel and a much less gritty smear than the coarser sand components.
<u>Silt:</u>	Components less than about 10 percent of the total weight can be identified by a slight discoloration of the fingers after smear of a moist sample. Increasing silt increases discoloration and softens the smear.

Sedimentation Test – A small sample of soil is shaken in a test tube filled with water and allowed to settle. The time required for the particles to fall to a distance of 4 inches is about ½ minute for particle sizes coarser than silt. About 50 minutes would be required for particles of 0.005 mm or smaller (often defined as “clay size”) to settle out.

Visual Characteristics – Sand and gravel particles can be readily identified visually, however, silt particles are generally indistinguishable to the eye. With an increasing silt component, individual sand grains become obscured, and when silt exceeds about 12 percent, it masks almost

entirely the sand component from visual separation. Note that gray fine-grained sand visually appears siltier than the actual silt content.

*Fine-grained (clay and silt)*

Soils with more than 50% of the particles finer than the No. 200 sieve (0.074 mm) and the fines are silts and clays.

A table of USC symbols and names for fine-grained soils is presented here.

**USCS Symbols and Names for Fine-grained Soils**

USCS Symbol	Typical Names
ML	Inorganic silts and very fine sands, rock flour, silty, or clayey fine sands, or clayey silts with slight plasticity
CL	Inorganic clays of low to medium plasticity, gravelly clays, sandy clays, silty clays, lean clays
OL	Organic silts and organic silty clays of low plasticity
MH	Inorganic silts, micaceous or diatomaceous fine sandy or silty soils, elastic silts
CH	Inorganic clays or high plasticity (residual clays), fat clays
OH	Organic clays of medium to high plasticity, organic silts
Pt	Peat and other highly organic soils

The following field identification tests can be used to estimate the degree of plasticity and size distribution of fine-grained soils:

Shaking (Dilatency) Test: Water is dropped or sprayed on a part of basically fine-grained soil mixed and held in the palm of the hand until it shows a wet surface appearance when shaken or bounced lightly in the hand or a sticky nature when touched. The test involves lightly squeezing the soil pat between the thumb and forefinger and releasing it alternatively to observe its reaction and the speed of the response. Soils which are predominantly silty (nonplastic to low plasticity) will show a dull dry surface upon squeezing and a glassy wet surface immediately upon releasing of the pressure. With increasing fineness (plasticity) and the related decreasing dilatency, this phenomenon becomes less and less pronounced.

**Dry Strength Test:** A portion of the sample is allowed to dry out and a fragment of the dried soil is pressed between the fingers. Fragments which cannot be crumbled or broken are characteristic of clays with high plasticity. Fragments which can be disintegrated with gentle finger pressure are characteristic of silty materials of low plasticity. Thus, materials with great dry strength are clays of high plasticity and those with little dry strength are predominantly silts.

**Thread Test:** Moisture is added or worked out of a small ball (approximately 1 ½-inch diameter) and the ball kneaded until its consistency approaches medium stiff to stiff, it breaks, or crumbles. A thread is then rolled out to the smallest diameter possible before disintegration. The smaller the thread achieved, the higher the plasticity of the soil. Fine-grained soils of high plasticity will have threads smaller than 1/32 inch in diameter. Soils with low plasticity will have threads larger than 1/8 inch in diameter.

**Smear Test:** A fragment of soil smeared between the thumb and forefinger or drawn across the thumbnail will, by the smoothness and sheen of the smear surface, indicate the plasticity of the soil. A soil of low plasticity will exhibit a rough textured, dull smear while a soil of high plasticity will exhibit a slick, waxy smear surface.

The following table presents the terms used to denote the various degrees of plasticity of soil that passes the No. 200 sieve.

**Degrees of Plasticity**

<b>Descriptive Term</b>	<b>Degree of Plasticity</b>	<b>Plasticity Index Range</b>
SILT	none	non-plastic
Clayey SILT	slight	1-5
SILT & CLAY	low	5-10
CLAY & SILT	medium	10-20
Silty CLAY	high	20-40
CLAY	very high	over 40

*Highly-organic*

Soils primarily consisting of organic matter. Identification markers are:

1. Dark and black and sometimes dark brown colors, although not all dark colored soils are organic.

2. Moist organic soils will oxidize when exposed to air and change from a gray/black color to a lighter brown, i.e. The exposed surface is brownish, but when the sample is pulled apart the freshly exposed surface is dark gray/black.
3. Fresh organic soils usually have a characteristic odor which can be recognized, particularly when the soil is heated.
4. Compared to non-organic soils, less effort is typically required to pull the material apart and a friable break is usually formed with a fine granular or silty texture and appearance.
5. Their workability at the plastic limit is weaker and spongier than an equivalent non-organic soil.
6. The smear, although generally smooth, is usually duller and appears siltier.

A table of soil descriptors is presented below.

#### Soil Descriptors

Calcareous:	Containing appreciable quantities of calcium carbonate
Fissured:	Containing shrinkage cracks, often filled with fine sand or silt, usually more less vertical
Interbedded:	Containing alternating layers of different soil types
Intermixed:	Containing appreciable, random, and disoriented quantities of varying color, texture, or constituency
Laminated:	Containing thin layers of varying color, texture, or constituency
Layer:	Thickness greater than 3 inches
Mottled:	Containing appreciable random speckles or pockets of varying color, texture, or constituency
Parting:	Paper thin
Poorly graded (well sorted):	Primarily one grain size, or having a range of sizes with some intermediate size missing
Slickensided:	Having inclined planes of weakness that are slick and glossy in appearance and often result in lower unconfined compression cohesion
Split graded:	Containing two predominant grain sizes with intermediate sizes missing

### Soil Descriptors

Varved:	Sanded or layered with silt or very fine sand (cyclic sedimentary couplet)	
Well graded (poorly sorted):	Containing wide range of grain sizes and substantial amounts of all intermediate particle sizes	
Modifiers:	Predominant type -	50% to 100%
	Modifying type -	12% to 50%
	With -	5% to 12%
	Trace -	1% to 5%

#### *Minor Soil Types*

In many soils two or more soil types are present in the soil. When the percentage of the minor soil type is  $\geq 30\%$  and  $< 50\%$  of the total sample, the minor soil type is given prior to the major soil type and is indicated by adding a “y” to its name; i.e. silty CLAY.

When the minor soil type percentage is between 1 and 29% of the total sample, the minor soil type is given after the major soil type is given along with an adjective term:

1. Trace – When the soil type’s percentage is between 1 and 12% of the total sample.
2. Some – When the soil type’s percentage is between 13 and 29% of the total sample.

#### *Inclusions*

Additional inclusions or characteristics of the sample can be described by using “with” and the descriptions described above. Examples are given below:

1. With petroleum odor
2. With organic matter
3. With shell fragments
4. With mica.

*Layered Soils*

Soils of different types can be found in repeating layers of various thicknesses. It is important that all such formations and their thicknesses are noted. Each layer is described as if it is a nonlayered soil using the sequence for soil descriptions discussed above. The thickness and shape of layers and the geological type of layering are noted using the following descriptive terms:

<b>Type of Layer</b>	<b>Thickness</b>	<b>Occurrence</b>
Parting	< 1/16 inch	
Seam	1/16 inch to 0.5 inches	
Layer	0.5 inches to 12 inches	
Stratum	> 12 inches	
Pocket		Small erratic deposit
Lens		Lenticular deposit
Varved (also layered)		Alternating seams or layers of silt and/or clay and sometimes fine sand
Occasional		One or less per foot of thickness of laboratory sample inspected
Frequent		More than one per foot of thickness of laboratory sample inspected

Place the thickness designation before the type of layer, or at the end of each description and in parentheses, whichever is appropriate.

An example of a description of layered soils is:

Medium stiff, moist to wet ¼” – ¾” interbedded seams and layers of: gray, medium plastic, silty CLAY (CL); and lt. gray, low plasticity SILT (ML); (Alluvium).

### Geologic Name

The soil description should include the Field Representative's assessment of the origin of the soil unit and the geologic name, if known, placed in parentheses at the end of the soil description or in the field notes column of the boring log.

A copy of the boring log to be used is included as Appendix B.

### *Rock*

The rock's description should include as a minimum:

- Rock type
- Color
- Grain size and shape
- Texture (stratification/foliation)
- Mineral composition
- Weathering and alteration
- Strength
- Other relevant notes.

The various elements of the rock's description should be stated in the order listed above.

Example:

Limestone, light gray, very fine-grained, thin-bedded, unweathered, strong

The rock description should include identification of discontinuities and fractures. The description should include a drawing of the naturally occurring fractures and mechanical breaks.

### Rock Type

Rocks are classified according to origin into three major divisions: igneous, sedimentary, and metamorphic. These three groups are subdivided into types according to mineral and chemical composition, texture, and internal structure. Engineering classifications of rocks can be based on ASTM Method C 294.

<b>Division</b>	<b>Class</b>	<b>Type</b>
Igneous	Coarse-grained (Intrusive)	Granite Syenite Diorite Gabbro Peridotite Pegmatite
	Fine-grained (Extrusive)	Volcanic Glass Delsite Basalt
Sedimentary Sedimentary (con't.)	Calcareous	Limestone Dolomite
	Siliceous	Conglomerate Sandstone Quartzite Claystone Siltstone Argillite Shale Chert
Metamorphic	Foliated	Slate Phyllite Schist Amphibolite Hornfers Unfixes
	Nonfoliated	Marble Metaquartzite Serpentinite

### *Color*

Colors should be assigned consistent with a Munsell Color Chart and recorded for both wet and dry conditions as appropriate. A Munsell Color Chart is provided as Appendix A.

### *Grain Size and Shape*

The grain size description should be classified using the following terms:

<u>Very Coarse-Grained:</u>	Diameter greater than 0.187 inches (4.76 mm).
<u>Coarse-Grained:</u>	Diameter 0.187 inches to 0.0787 inches (4.76 mm to 2.00 mm). Individual grains can be easily distinguished by the naked eye.
<u>Medium-Grained:</u>	Diameter 0.0787 inches to 0.0165 inches (2.00 mm to 0.420 mm). Individual grains can be distinguished with the naked eye.
<u>Fine-Grained:</u>	Diameter 0.0165 inches to 0.0029 inches (0.420 mm to 0.074 mm). Individual grains can be distinguished by the naked eye with difficulty.
<u>Very Fine-grained:</u>	Diameter less than 0.0029 inches (0.074 mm). Individual grains cannot be distinguished by the naked eye.

The grain shape description should be classified using the following terms:

<u>Angular:</u>	Showing very little evidence of wear. Grain edges and corners are sharp. Secondary corners are numerous and sharp.
<u>Subangular:</u>	Showing definite effects of wear. Grain edges and corners are slightly rounded off. Secondary corners are slightly less numerous and slightly less sharp than in angular grains.
<u>Subrounded:</u>	Showing considerable wear. Grain edges and corners are rounded to smooth curves. Secondary corners are reduced greatly in number and highly rounded.
<u>Rounded:</u>	Showing extreme wear. Grain edges and corners are smoother off to broad curves. Secondary corners are few in number and rounded.
<u>Well-Rounded:</u>	Completely worn. Grain edges or corners are not present. No secondary edges or corners are present.

#### *Texture (stratification/foliation)*

Significant nonfracture structural features should be described. The thickness should be described using the following terms:

Type of Layer	Thickness	
	English	Metric
Thinly laminated	0.1 inches	2.5 millimeters
Laminated	0.1 to 0.5 inches	2.5 to 10 millimeters
Very thinly bedded	0.5 to 2.0 inches	1 to 5 centimeters
Thinly bedded	2.0 inches to 2 feet	5 to 50 centimeters
Thickly bedded	2 to 3 feet	0.5 to 1 meters
Very thickly bedded	3 feet	1 meter

The orientation of the bedding/foliation should be measured from the horizontal with a protractor.

#### *Mineral Composition*

A geologist based on experience and the use of appropriate references should identify the mineral composition. The most abundant mineral should be listed first, followed by minerals in decreasing order of abundance. For some common rock types, mineral composition need not be specified (i.e. dolomite, limestone).

#### *Weathering and Alteration*

Weathering as defined here is due to physical disintegration of the minerals in the rock by atmospheric processes while alteration is defined here as due to geothermal processes. Terms and abbreviations used to describe weathering or alteration are:

- RS Residual Soil – The original minerals of the rock have been entirely weathered to secondary minerals, and the original rock fabric is not apparent. The material can be easily broken.
- C Completely Altered or Weathered – The original minerals of the rock have been almost entirely changed to secondary minerals, even though the original fabric may be intact. The material can be easily broken.
- H Highly Altered or Weathered – The rock is weakened to such an extent that a sample with a 2-inch minimum diameter can be broken readily by hand across the rock fabric. More than half the rock material is decomposed or altered. Fresh rock is present in a discontinuous framework or as corestones.

- M Moderately Altered or Weathered – rock is discolored and noticeably weakened, but sample with a 2-inch minimum diameter cannot usually be broken by hand, across the rock fabric. Less than half of the rock material is decomposed or altered. Fresh or discolored rock is present either as a continuous framework or as corestones.
- S Slightly Altered or Weathered – Rock is slightly discolored, but not noticeably lower in strength than fresh rock.
- F Fresh – Rock shows no discoloration, no loss of strength, or any other effect of weathering.

### Strength

A common qualitative assessment of strength can be used while logging of rock core during drilling. Terms and abbreviations used to describe weathering or alteration are:

- ES Extremely Strong – Specimen can only be chipped with geological hammer.
- VS Very Strong – Specimen requires many blows of geologic hammer to fracture it.
- S Strong – Specimen requires more than one blow of geological hammer to fracture it.
- MS Medium Strong – Cannot be scraped or peeled with a pocketknife. Specimen can be fractured with a single firm blow of geological hammer.
- W Weak – material crumbles under firm blows with the sharp end of a geological hammer. Can be peeled by a pocketknife with difficulty.
- VW Very Weak Rock – Brittle or tough, may be broken in the hand with difficulty. Can be peeled with a pocketknife.

Descriptors and abbreviations used to describe rock hardness are:

- S Soft - Reserved for plastic material alone.
- F Friable - Easily crumbled by hand, pulverized or reduced to powder and is too soft to be cut with a pocketknife.
- LH Low Hardness - Can be gouged deeply or carved with a pocketknife.
- MH Moderately Hard - Can be readily scratched by a knife blade; scratch leaves heavy trace of dust and scratch is readily visible after the powder has been blown away.

- H      Hard - Can be scratched with difficulty; scratch produces little powder and is often faintly visible; traces of the knife steel may be visible.
- VH     Very Hard - Cannot be scratched with pocketknife. Leaves knife steel marks on surface.

### *Rock Discontinuity*

Discontinuity is the general term for any mechanical discontinuity in a rock mass having zero or low tensile strength. It is the collective term for most types of joints, weak bedding planes, weak schistosity planes, weakness zones, and faults. The following symbols are recommended for the type of rock mass discontinuities.

F	Fault
J	Joint
Sh	Shear
Fo	Foliation
V	Vein
B	Bedding

The spacing of discontinuities is the perpendicular distance between adjacent discontinuities. The spacing should be measured in feet to the nearest tenth, perpendicular to the planes in the set.

EC	Extremely close spacing	<0.07 ft
VC	Very close spacing	0.07 – 0.2 ft
C	Close spacing	0.2 – 0.66 ft
M	Moderate spacing	0.7 – 2 ft
W	Wide spacing	>2 – 6.6 ft
EW	Extremely wide spacing	>6.6 ft

The discontinuities should be described as closed, open, or filled. Aperture is used to describe the perpendicular distance separating the adjacent rock walls of an open discontinuity in which the intervening space is air or water filled. Width is used to describe the distance separating the adjacent rock walls of filled discontinuities. The following terms should be used to describe apertures:

Aperture	Description	
<0.1 mm 0.1 – 0.25 mm 0.2 0.25 – 0.5 mm	Very tight Tight Partly open	“Closed Features”
0.5 – 2.5 mm 2.5 – 10 mm >10 mm	Open Moderately open Wide	“Gapped Features”
1 10 cm 1 10 – 100 cm >1 m	Very wide Extremely wide Cavernous	“Open Features”

The following terms are recommended to describe the width of discontinuities such as thickness of veins, fault gouge filling, or joints openings.

W	Wide	0.5 – 2.0 inches
MW	Moderately wide	0.1 – 0.5 inches
N	Narrow	0.05 – 0.1 inches
VN	Very narrow	<0.05
T	Tight	0

For the thickness of faults or shears that are not thick enough to be represented on the boring log and are greater than 2-inches thick, record the measured thickness numerically in feet to the nearest tenth of a foot.

The following terms should be used to describe the planarity of discontinuities:

Wa	Wavy
Pl	Planar
St	Stepped

Amplitude = A

Wavelength =  $\gamma$

Measured in feet.

The following terms should be used to describe the surface roughness of discontinuities:

VR	<u>Very Rough</u> – Near right-angle steps and ridges occur on the discontinuity surface.
R	<u>Rough</u> – Some ridges and side- angle steps are evident; asperities are clearly visible; and discontinuity surface feels very abrasive.
Sr	<u>Slightly Rough</u> – Asperities on the discontinuity surfaces are distinguishable and can be felt.
S	<u>Smooth</u> – Surface appears smooth and feels so to the touch.
Slk	<u>Slickensides</u> – Visual evidence of striations or a smooth glassy appearing finish.

Filling is the term for material separating the adjacent rock walls of discontinuities. The perpendicular distance between the adjacent rock walls is termed the width of the filled discontinuity. The type of discontinuity infilling should be described using the following terms:

C	Clay	Fe	Iron Oxide
Sd	Sand	g	Gypsum/Talc
H	Healed	q	Quartz
Ch	Chlorite	N	None
Ca	Calcite	O	Other (describe)

The amount of infilling in discontinuities should be described using the following terms:

St	Surface stain
Sp	Spotty
P	Partially filled half surface or opening is filled
F	Filled
N	None.

### *Fracture Description*

The location of each naturally occurring fracture and mechanical break is shown in the fracture column of the rock core log. The naturally occurring fractures are numbered and described using the terminology described above for discontinuities.

The naturally occurring fracture and mechanical breaks are sketched in the drawing column.

Dip angles of fractures should be measured using a protractor and marked on the log. For nonvertical borings, the angle should be measured and marked as if the boring was vertical. If the rock is broken into many pieces less than ½ inch to 1-inch long, the log may be crosshatched in that interval or the fracture may be shown schematically.

The number of naturally occurring fractures observed in each foot of core should be recorded in the fracture frequency column. Mechanical breaks, thought to have occurred due to drilling, are not counted. The following criteria can be used to identify natural breaks:

1. A rough brittle surface with fresh cleavage planes in individual rock minerals indicates an artificial fracture.
2. A generally smooth or somewhat weathered surface with soft coating or infilling materials, such as talc, gypsum, chlorite, mica, or calcite obviously indicates a natural discontinuity.
3. In rocks showing foliation, cleavage or bedding it may be difficult to distinguish between natural discontinuities and artificial fractures when these are parallel with the incipient weakness planes. If drilling has been carried out carefully then the questionable breaks should be counted as natural features, to be on the conservative side.
4. Depending upon the drilling equipment, part of the length of core being drilled may occasionally rotate with the inner barrels in such a way that grinding of the surfaces of discontinuities and fractures occurs. In weak rock types it may be very difficult to decide if the resulting rounded surfaces represent natural or artificial features. When in doubt, the conservative assumption should be made; i.e., assume that they are natural.
5. It may be useful to keep a separate record of the frequency of artificial fractures (and associated lower RQD) for assessing the possible influence of blasting on the weaker sedimentary and foliated or schistose metamorphic rocks.

The results of core logging (frequency and RQD) can be strongly time dependent and moisture content dependent in the case of certain varieties of shales and mudstones having relatively weakly developed diagenetic bonds. A not infrequent problem is “discing,” in which an initially intact core separates into discs on incipient planes, the process becoming noticeable perhaps within minutes of core recovery. The phenomena are experienced in several different forms:

1. Stress relief cracking (and swelling) by the initially rapid release of strain energy in cores recovered from areas of high stress, especially in the case of shaley rock.

2. Dehydration cracking experienced in the weaker mudstones and shales which may reduce RQD from 100 to 0 percent in a matter of minutes, the initial integrity possibly being due to negative pore pressure.
3. Slaking cracking experienced by some of the weaker mudstones and shales when subjected to wetting.

All these phenomena make core logging of *frequency* and RQD unreliable. Whenever such conditions are anticipated, an engineering geologist should log core as it is recovered and at subsequent intervals until the phenomenon is predictable. An added advantage is that the engineering geologist can perform mechanical index tests, such as the point load or Schmidt hammer test, while the core is still in a saturated state.

5. *Drilling information:*

- Drill rig manufacturer, model, and driller (if applicable)
- Geologist or geotechnical engineer
- Project name, sample point identification, and location
- Date samples obtained (and times if required)
- Type of sampler (e.g., split spoon, Shelby, California), measurements or method of advancing boring or equipment, method of driving sampler, and weight of hammer
- Drill fluids (if applicable)
- Ground surface or grade elevation (if known)
- Depth penetrated and blow counts/6-inch interval of penetration for ASTM 1586-84 and sample number (if applicable)
- Closed hole intervals and advancement (if applicable)
- Recovery
- Strata changes and changes within samples
- Sampling tool behavior
- Drill string behavior
- Use(s) of borehole
- Disposition(s) of residual soil or cuttings
- Signature or sampling of log (as required).

## 1. Objective

This document defines the standard operating procedure (SOP) and necessary equipment for collection of groundwater samples in monitoring wells, extraction wells, or piezometers using low-flow techniques. The term “Low Flow” refers to the velocity that the groundwater is removed from the soil formation immediately adjacent to the well screen.

In this technique, in order to withdraw water from within the well screen and to lessen drawdown, a pump that minimizes disturbance to the groundwater is operated at a low flow rate. The well is only purged within the screened interval until specific parameters have stabilized and as according to the site-specific work plan. Therefore, the groundwater samples collected are representative of the water bearing formation and hydraulically isolated from the water in the casing. The need to purge three well volumes, as required in traditional techniques, is not necessary with low flow purging and sampling. The low flow procedure described in this SOP is not necessarily applicable for every site or for wells screened in materials with very low permeability.

SOPs providing additional related guidance are listed below:

- SOP No. 4 – Decontamination
- SOP No. 8 – Field Reporting and Documentation.
- SOP No. 10 – Groundwater Level Measurements
- SOP No. 20 – Monitoring Well Development and Purging
- SOP No. 24 – Sample Classification, Packaging and Shipping
- SOP No. 25 – Sample Containers, Preservation, and Holding Times
- SOP No. 26 – Sample Control and Custody Procedures.

## 2. Equipment

Equipment potentially used during well purging and sampling:

- Well installation forms and boring logs for well being sampled
- Well keys
- Disposable latex or nitrile gloves
- Assorted tools (knife, screwdriver, etc.)
- New synthetic rope

- Pump and required accessories (described in more detail in following section)
- Electronic water level indicator with 0.01-foot increments
- Graduated cylinder
- Temperature meter
- pH meter (with automatic temperature compensation)
- Conductivity meter
- Turbidity meter
- Dissolved oxygen (DO) meter
- Oxidation reduction potential (ORP) meter
- Flow-through cell
- Calibration fluids
- Paper towels or Kimwipes
- Calculator
- Bound field logbook (logbook)
- Waterproof pen and permanent marker
- Plastic buckets
- 55-gallon drums or truck-mounted tank
- Plastic sheeting
- Appropriate decontamination equipment (see SOP No. 4)
- Cooler with ice
- Sample containers and labels
- Groundwater sampling form
- Chain-of-Custody form
- Appropriate health and safety equipment (e.g., photoionization detector (PID)).

### 3. Sampling Procedure

This section provides the step-by-step procedure for collecting groundwater samples in the field. Observations made during groundwater purging and sampling should be recorded in a logbook in accordance with procedures described in SOP No. 8.

- A. Any equipment used in the sampling procedure that could contact groundwater should be properly decontaminated before each use (see SOP No.4).
- B. Equipment should be calibrated based on the manufacturers' instructions. The frequency of calibration should be specified in the site-specific Field Sampling Plan (FSP), Quality Assurance Project Plan (QAPP) or work plan. According to "Low-Flow (Minimal Drawdown) Ground-Water Sampling Procedures" (Unites States Environmental Protection Agency (USEPA), 1996), pH calibration should be performed with at least two buffers that bracket the expected range of values. Dissolved oxygen calibration must be corrected for local barometric pressure readings and elevation.
- C. Before well purging begins, the following steps should be performed at each well:
  - Inspect the well and surrounding site for security, damage, and evidence of tampering. If damage or tampering is evident, contact the project manager for guidance.
  - Place clean plastic sheeting around the well (as necessary)
  - Measure ambient volatile organic compounds (VOCs) background levels in the immediate vicinity of the well (i.e., using a PID or a flame ionization detector (FID) per the Health and Safety Plan (HASp)).
  - Remove the well cap and immediately measure VOCs at the rim of the well and record the readings in the logbook or on the groundwater sampling form. Give the water in the well adequate time to reach equilibrium.
- D. After the well has reached equilibrium, the groundwater elevation should be measured to the nearest 1/100-foot. The total well depth and screened interval should be obtained from the well logs. Measuring the total depth prior to sampling should be avoided to prevent resuspension of settled solids in the well casings and to minimize the necessary purge time for turbidity equilibration. The total depth of the well should be confirmed after sampling has been completed, if necessary. A detailed description of monitoring well gauging activities is provided in SOP No. 10.

- E. Following measurement of the static groundwater elevation, the appropriate equipment will be slowly and carefully placed in the well. If the wells have light or dense non-aqueous-phase liquids (LNAPLs or DNAPLs) and are still to be sampled, care should be taken to place sampling equipment below or above the NAPL.

Selection of the proper pump is important for low-flow sampling activities. USEPA guidance (1996) notes that dedicated sampling devices capable of purging and sampling are preferred over any other type of device. In addition, the pump must be capable of flow rates between 0.1 and 1.0 liter per minute. A variety of portable sampling devices are available, such as bladder pumps, peristaltic pumps, electrical submersible pumps, gas-driven pumps, inertial lift foot-valve samplers (e.g. check-ball systems), and bailers (a list of pump manufacturers and suppliers is included on pg. 8). However, some of this sampling equipment has drawbacks or has been specifically rejected for low-flow sampling. The peristaltic pump can only be used for shallow applications and it can cause degassing of groundwater. Degassing results in the alteration of pH and alkalinity values as well as some loss of volatiles. Also, USEPA guidance asserts that inertial lift foot-valve type samplers and bailers cause too much groundwater disturbance and may invite unacceptable operator variability. Therefore, these sampling devices should be avoided for low-flow sampling activities.

When placing the equipment in the well, the pump intake should be set near the middle or slightly above the middle of the screened interval or water column, whichever is deeper. In situations in which contaminants of interest are known to concentrate near the top or the bottom of the screened zone it may be desirable to position the pump intake to target this zone instead.

- F. Tubing should be connected from the pump to a flow-through cell. Then, calculate the volume of water to fill the flow-through cell. According to American Society for Testing and Materials (ASTM) Standard D 6771 (2002), the frequency of measurements should be equal to the time required to completely evacuate one volume of the cell (minimum). This ensures that independent measurements are made.
- G. The pump should be started at a low flow rate, approximately 100 mL/min or the lowest flow rate possible. The pumping rate can be increased up to 500 mL/min as long as significant drawdown does not occur (200 to 300 mL/min is the optimum flow rate for sampling VOCs).
- H. Water level measurements should continue every two minutes until the measurements indicate that significant drawdown is not occurring. According to ASTM standards (2002), allowable

drawdown should never exceed the distance between the top of the well screen and the pump intake. Including a safety factor, also provided by ASTM, drawdown should actually not exceed 25% of this distance. This ensures that water stored in the casing is not purged or sampled. For example, for a 4-foot screen, the pump should be placed at the midpoint of the screen (two feet from the top of the screen to the pump intake). With a safety factor of 25%, this would require drawdown not to exceed six inches.

If drawdown surpasses 25% of the distance from the pump intake to the top of the screen even while pumping is occurring at the lowest flow rate possible, samplers should refer to the project specific criteria as found in the appropriate FSP or work plan.

- I. Parameters should be documented on the groundwater sampling form and in the logbook. The time between parameter measurements is calculated as follows:

$$T = \frac{V}{Q}, \text{ where}$$

$T$  = time between measurements (minutes)

$V$  = volume of the flow-through cell (liters)

$Q$  = purge flow rate (liters per minute)

- J. Sampling should be as stated in the FSP or work plan. However, in most cases, purging will continue until specific parameters have stabilized over three consecutive flow-through cell volumes or until a specific time requirement is met, whichever happens first. **Table 1** provides guidelines that may be used for parameter stabilization as specified by USEPA, ASTM, and in the Nielsen and Nielsen Technical Guidance on Low-Flow Purging and Sampling and Minimum-Purge Sampling (Nielsen and Nielsen, 2002). These guidelines are to be used in combination with professional judgment.

**Table 1. Stabilization Guidelines for Low-Flow Sampling**

Parameter	Stabilization Guidelines		
	EPA	ASTM	Nielsen & Nielsen
DO	+/- 10%	+/- 10% or +/-0.2 mg/L, whichever is greatest	+/- 10% or +/-0.2 mg/L, whichever is greatest
ORP	+/- 10 mV	+/- 20 mV	+/- 20 mV
PH	+/- 0.1 units	+/- 0.2 units	+/- 0.2 units
Conductivity	+/- 3%	+/- 3%	+/- 3%
Temperature	Not Specified	Not Specified	+/- 0.2 °C
Turbidity	+/- 10%	Not Specified	Not Specified

- K. After the relevant parameters have stabilized, the flow-through cell should be disconnected or bypassed for sampling. If, after a considerable number of readings have been taken, parameters have not stabilized, samplers should refer to the work plan or possibly use alternative sampling methods.
- L. A new pair of disposable latex or nitrile gloves should be put on immediately before sampling.
- M. The constituents should be sampled for in the order given below:
- VOCs – Vials should be filled completely so that the water forms a convex meniscus then capped so that no air space exists in the vial. Turn the vial over and tap it to check for bubbles. If air bubbles are observed in the sample vial, remove the lid and attempt to fill the vial two more times, (being careful not to dump out any groundwater currently in the vial). If air bubbles are present twice more, discard the sample vial and repeat the procedure with a new vial. If, after three attempts, air bubbles are still in the vial, make a note of this and place the vial in the cooler.

- Gas sensitive parameters (e.g., ferrous iron, methane, alkalinity)
  - Semivolatile organic compounds, pesticides, polychlorinated biphenyls, and herbicides
  - Petroleum hydrocarbons
  - Metals (unfiltered)
  - Explosives
  - Any filtered analytes (use in-line filters if possible)
- O. Place all samples on ice inside a cooler immediately.
- P. Each sample should be identified with the Sample ID, location, analysis number, preservatives, date and time of sampling event, and sampler.
- Q. The sample time and constituents to be analyzed for should be recorded in the logbook and on the groundwater sampling form.
- R. Chain-of-custody procedures should be started.
- S. Sample equipment should be decontaminated.
- T. The well sampling order should be dependent on expected levels of contamination in each well, if known, and should be determined prior to sampling. Sampling should progress from the least contaminated to the most contaminated well. Quality assurance/quality control (QA/QC) samples should be collected during groundwater sampling as required in the work plan and/or QAPP.
4. *List Of Potential Suppliers Who Provide Pumps Suitable for Low-Flow Sampling:*
- Field Environmental. 1-800-3930-4009. [www.fiieldenvironmental.com](http://www.fiieldenvironmental.com). Pumps: peristaltic, QED bladder pumps, Fultz rotor pump, control boxes, compressors, etc.
- QED. 1-800-624-2026. [www.micropurge.com](http://www.micropurge.com). Pumps: bladder pumps, flow cell, compressors, etc.
- Fultz Pumps. 1-717-248-2300. [www.fultzpumps.com](http://www.fultzpumps.com).

5. *References*

ASTM 2002, Standard Practice for Low-Flow Purging and Sampling for Wells and Devices Used for Ground-Water Quality Investigations, ASTM D6771-02, American Society for Testing and Materials. West Conshohocken, PA.

Nielsen, David and Nielsen, Gillian. Technical Guidance on Low-Flow Purging and Sampling and Minimum-Purge Sampling. Second Edition. NEFS-TG001-02. April 2002.

USEPA. 1996. Low-Flow (Minimal Drawdown) Ground-Water Sampling Procedures. EPA/540/S-95/504. OSWER, April 1996.

## 1. Well Development

The objective of groundwater monitoring well development is to clear the well of accumulated sediments, when 10% or more of the well screen has been occluded by sediment, so that representative groundwater samples may be collected. The accumulated sediments need to be re-suspended in the water column in order to be removed. A variety of techniques can be used to re-suspend the sediments. Some of the common methods that can be used to re-suspend sediments include using a surge block, injection of air into the water column of the well, or using a bailer. Once the sediment is re-suspended, the water and sediment can then be removed from the well using a submersible pump, an air bladder pump, or a bailer. Development will be considered to be complete when the fine-grained materials have been removed.

The preferred method for development will be surging and removing water with dedicated, disposable, polyethylene bailers or a submersible pump. The following procedures will be used when developing an existing well.

1. Place a clean, plastic drop cloth on the ground around the well to be developed.
2. Unlock the protective well cover and remove the well cap.
3. Check the well for NAPL using an interface probe, as outlined in the water level measurement section below.
4. Measure the depth to groundwater and/or NAPL to the nearest hundredth of a foot.
5. Measure the total depth of the well to the nearest hundredth of a foot. Note whether the bottom of the well feels hard or soft.
6. Attach the decontaminated surge block to the appropriate lengths of pole section and push the surge block to the bottom of the well, or send a bailer to the bottom of the well.
7. Pull and push the surge block/bailer up and down to agitate the water and suspend the sediments in the well.
8. Once sufficient re-suspension has occurred, pull the surge block/bailer out of the well.
9. Attach an appropriate length of polyethylene tubing to a submersible pump, and lower the pump to near the bottom of the well, out of sediment that may be remaining in the bottom of the well.
10. Place the discharge end of the tubing such that purged water will be collected in a poly-tank, 55-gallon drum, or other.

11. Turn on the pump and adjust the flow rate to pump at a sufficiently high rate to allow the sediments to be removed without causing the pump to clog.
12. Continue pumping until relatively sediment-free water is obtained.
13. Remove the pump and allow the well to recover for half an hour. Re-measure the total well depth. If the measured depth indicates 10% or more occlusion, repeat steps 8 through 14. If the measured depth indicates less than 10% well screen occlusion, disconnect the tubing from the pump and place into the appropriate waste container. Dismantle the surge block and pole connectors for decontamination. Pick up and appropriately dispose of plastic sheeting and other disposables into the appropriate waste container. Close and properly label the 55-gallon drum(s).
14. Decontaminate the pump, wiring, and any other equipment, using the steam cleaner.

Note in the field log book the approximate number of gallons of water removed during development of each well.

## 2. Well Purging

Prior to initiating the well purging process, the following information will be recorded in a field notebook and on the groundwater sampling logs.

- Well number
- Day, date, and time
- Weather conditions
- Condition of the well and surrounding area
- Sampling team members
- Instrument calibration information
- Water level prior to purging
- Depth to the bottom of the well
- Volume of water to be purged
- Physical properties of evacuated water: color, odor, turbidity, presence of non-aqueous phase liquids
- Deviations from planned sampling methodology
- Ambient air monitoring readings.

Low-flow purging techniques will be used to purge the well in accordance with RCRA Groundwater Monitoring TEGD guidelines. These guidelines state that purging will be conducted by removing a minimum of three well volumes of fluid. A well volume of water is calculated using the following formula:  $V = \pi r^2 h(7.48)$  where

V = Standing water volume in gallons to be purged

$r^2$  = Inside radius of well in feet, squared

h = Linear feet of standing water in the casing

One well volume will be calculated so field personnel know when to perform field measurements. Such measurements are performed after the removal of each well volume.

In groundwater systems, naturally occurring metals tend to adsorb to the surfaces of solids. The level of adsorbance depends on the pH of the soil and water. The concentration of metals in dissolved form, therefore, is limited by this adsorption and by the metals' low solubilities. Sediment in water is likely to have metal ions adsorbed to its particles, which analytical methods may not be able to differentiate from metal ions dissolved in the water. Groundwater samples that contain sediment, therefore, may yield analytical results that do not represent the concentration of metals in the groundwater itself.

Moreover, the transport of sediment is generally not due to the natural flow of groundwater, but is induced by the sampling. Samples that are collected for metals analysis should exhibit low turbidity, and they are generally filtered to remove sediment. When possible, low turbidity samples should be obtained without filtering. A turbidity meter will be used to monitor turbidity during sampling. Following the extraction of each well volume, turbidity will be monitored in the field. Additionally, pH, conductivity, and temperature will be measured and recorded after each well volume removed. Purging is deemed complete when these parameters have stabilized within 10% over a minimum of two successive well volumes. Samples will be collected when turbidity levels are below 5 nephelometric turbidity units (NTU). Should a turbidity level of 5 NTU be unachievable after 2 hours of purging, the samples will be collected and the turbidity recorded.

The procedures for well purging are described as follows:

- The low-flow pump will be lowered into the well, and the pump intake will be located at the approximate midpoint of the screened interval. Once the pump is in place, the controller will be set for the desired flow rate. The optimum flow rate is dependent on

the site-specific hydrogeology and will be determined in the field, however, the flow rate will not exceed 1 L/min.

- Pump the groundwater into a graduated pail. Continue pumping until the turbidity reading is at or below 5 NTU unless that is unattainable then the turbidity reading is within 10% for two consecutive well volumes, the well is pumped dry.
- If the well is purged dry, allow sufficient time for the well to recover before proceeding. Record this information on the groundwater sampling log.
- In addition to the turbidity readings, in wells which exhibit sufficient recharge, also collect pH, conductivity, and temperature measurements. A minimum of two consecutive measurements should be within the following criteria:
  - $\pm 0.2$  units for pH
  - $\pm 10\%$  for specific conductivity
  - $\pm 1$  C° for temperature

Record this information on the groundwater sampling log.

Discharge the water removed during purging or possible decontamination procedures into 55-gallon drums for disposal.

## 1. Summary

The purpose of this Standard Operating Procedure (SOP) is to define the procedures and necessary equipment for installation of groundwater monitoring wells and piezometers. A piezometer is simply a small diameter monitoring well. Therefore, the equipment and procedures for building a piezometer are the same as those used to install any monitoring well. The step-by-step procedures described herein are sufficiently detailed to allow field personnel to properly install any size monitoring well. Other related SOPs are listed below:

- SOP No. 4 – Decontamination
- SOP No. 8 – Field Reporting and Documentation
- SOP No. 17 – Logging
- SOP No. 28 – Soil Sampling.

## 2. Equipment

This section details the required equipment for the drilling and installation of groundwater monitoring wells.

The following is an equipment list typical for well drilling and installation:

- Drill rig capable of installing wells to the desired depth in the expected formation materials and conditions
- Well casing and well screen
- Bentonite pellets or chips
- Filter pack sand
- Portland Type I or II Cement and powdered bentonite for grouting
- Protective well casing with locking cap
- High-pressure steamer/cleaner
- Long-handled bristle brushes
- Wash/rinse tubs
- Appropriate decontamination supplies as specified in SOP No. 4 - Decontamination
- Location map
- Plastic bags (Ziploc)

- Self-adhesive labels
- Weighted tape measure
- Water level probe
- Deionized or distilled water
- Appropriate health and safety equipment as specified in the Health and Safety Plan (HSP)
- Log book
- Boring log sheets
- Well construction form
- Plastic sheeting
- Drums for containment of cuttings and Decontamination and/or development water (if necessary).

### 3. Procedures

#### *Decontamination*

Before drilling or well installation begins, all drilling and well installation material will be decontaminated according to the protocols listed in SOP No. 4 - Decontamination. Drilling equipment will be decontaminated between well locations.

#### *Instrument Calibration*

Before going into the field, the sampler shall verify that field instruments are operating properly. Calibration times and readings will be recorded in a notebook or on calibration sheets to be kept by the field sampler. Specific instructions for calibrating the instruments are given in the respective SOPs.

#### *Drilling and Well Installation Procedures*

##### Drilling Technique

If soil sampling is required, all soil samples will be taken following the protocol outlined in SOP No. 28 - Soil Sampling. The hole will be logged following the methods specified in SOP No. 17 – Logging.

Boreholes will be advanced using drilling methods specified in the Work Plan and a drill rig capable of completing the monitor well(s) to the depth(s) specified in the Scope of Work. Before drilling, well locations will be numbered and staked. The necessary permits and utility clearances will be obtained

prior to commencement of drilling activities. Appropriate health and safety measures will be followed during drilling and well installation activities as specified in the Health and Safety Plan.

During the drilling operation, the cuttings from the boring will be containerized or placed directly onto the ground as specified in the Work Plan. Disposal of cuttings will be in accordance with the Work Plan.

#### Monitor Well Drilling Operations

The procedures for drilling are as follows:

- Set up drilling rig at staked and cleared borehole location.
- Record location, date, time and other pertinent information in the field book.
- Drill hole of appropriate size using hollow-stem augers.
- Collect samples at the predetermined intervals, if appropriate, for sample description and/or chemical analysis as specified in the Work Plan. See SOP No. 17 - Logging for instruction.
- Complete the borehole to the depth specified in the Work Plan.

#### Well Design Specifications

The following general specifications will be:

**Boring Diameter:** The boring will be of sufficient diameter to permit at least two inches of annular space between the boring wall and all sides of the centered riser and screen. The boring diameter will be of sufficient size to allow for the accurate placement of the screen, riser, filter pack, seal, and grout.

**Well Casing:** Well riser will consist of new threaded, flush joint, PVC or stainless steel. Well diameter and thickness will be specified in the Work Plan. Risers will extend approximately two feet above the ground surface, except in the case of flush-mount surface casings (see Work Plan for appropriate construction). The tops of all well casings will be fitted with expandable locking caps or PVC slip caps.

**Well Screens:** Screen length for each well will be specified in the Work Plan. Well screens will consist of new threaded pipe with factory-machine slots/ wrapped screen with an inside diameter equal to or greater than that of the well casing. The slot size will be indicated in the Work Plan and designed to be compatible with aquifer and sand pack material. The schedule thickness of PVC screen will be the same as that of the well casing. All screen bottoms will be fitted with a cap or

plug of the same composition as the screen and should be within 0.5 foot from the open part of the screen. Traps may be used.

#### Well Installation Procedure

The following procedures will be initiated within 12 consecutive hours of boring completion for uncased holes or partially cased holes and within 48 consecutive hours for fully cased holes. Once installation has begun, no breaks in the installation procedure will be made if no unusual conditions are encountered until the well has been grouted and the drill casing has been removed.

The procedure for monitoring well installation is as follows:

1. Decontaminate all well materials according to SOP No. 4 - Decontamination. Following decontamination, all personnel that handle the casing will don a clean pair of rubber or surgical gloves.
2. Measure each section of casing, and screen, to nearest 0.10 foot.
3. Assemble screen and casing as it is lowered into the borehole.
4. Lower screen and casing to about 6 inches above the bottom of the boring.
5. Record the level of top of casing and calculate the screened interval. Adjust screen interval by raising assembly to desired interval if necessary and add sand to raise the bottom of the boring.
6. Calculate and record the volume of the filter pack, bentonite seal, and grout required for existing boring conditions.
7. Begin adding filter pack sand around the annulus of the casing a few feet at a time. Repeated depth soundings shall be taken to monitor the level of the sand.
8. Allow sufficient time for the filter sand to settle through the water column outside the casing before measuring the sand level.
9. Extend the filter pack sand to at least 2 feet above the top of the well screen.
10. Following sand filter pack placement in the shallow wells, install a minimum 3 foot-thick seal of bentonite pellets or chips by slowly adding the pellets to avoid bridging. The thickness of the completed bentonite seal shall be measured before the pellets are allowed to swell. The completed bentonite seal shall be allowed to hydrate before proceeding with the grouting operations.
11. Grout the remaining annulus from the top of the bentonite seal to about 3 feet below the surface as measured after the augers are removed. The grout will be tremied into the borehole

until the annulus is completely filled. The base of the tremie pipe should be placed approximately 5 feet above the bentonite seal.

12. After the grout sets for 24 hours it will be checked for settlement. If necessary, additional grout will be added to top off the annulus.
13. The concrete pad and bollards, if required, will be installed according to specifications in this SOP. The protective casing and posts will be painted a high visibility color.
14. Optional - URS personnel will affix a permanent, non-corrosive tag to the outer steel protective casing of each well which clearly identifies the well number.

#### Well Installation Specifications:

**Filter Pack:** The annular space around the well screen will be backfilled with a clean, washed, silica sand sized to perform as a filter between the formation material and the well screen. The filter pack will extend a minimum two feet above the screen and may be tremied into place. The final depth to the top of the filter pack will be measured directly using a weighted tape measure or rod and not by using volumetric calculation methods. The grain size of the filter pack will be shown on the well construction log.

**Bentonite Seal and Grout:** A minimum two-foot thick bentonite pellet/slurry seal will be placed in the annulus above the filter pack. The thickness of the seal may vary slightly based on site conditions. The thickness of the seal will be measured immediately after placement, without allowance for swelling. Bentonite slurry seals should have a thick batter-like consistency. Slurry seals will have a maximum placement thickness of 8 feet. Cement grout will then be placed from the top of the bentonite seal to the ground surface. The cement grout will consist of a mixture of Portland cement (ASTM C150) and clean water in the proportion of not more than seven gallons of clean water per bag of cement (one cubic foot or 94 pounds). Additionally, three percent by weight of bentonite powder will be added if permitted by state regulations. The grout will be prepared in an above-ground rigid container by first thoroughly mixing the cement with water and then mixing in the bentonite powder. The grout will be placed by pumping through a tremie pipe. The lower end of the tremie pipe will be kept within five feet of the top of the bentonite seal. Grout will be pumped through the tremie pipe until undiluted grout flows from the annular space at the ground surface. The tremie pipe will then be removed and more grout added to compensate for settling. After 24 hours, the drilling contractor will check the site for grout settlement and add more grout to fill any depression. This will be repeated until firm grout remains at the surface.

**Protection of Well:** URS personnel will at all times during the progress of the work, take precautions to prevent tampering with the wells or entrance of foreign material into them. Upon completion of a well, a suitable cap will be installed to prevent foreign material from entering the well. The wells will be enclosed in a steel protective casing. Steel casings will be, at a minimum, 4 inches in diameter and will be provided with locking caps and locks. All locks will be keyed alike. If the well is to be a stickup, as specified in the Work Plan, a 1/4-inch drainage hole will be drilled in the protective steel casing centered approximately 1/8-inch above the internal mortar collar for drainage. The well designation will be painted on the protective casing, using a brush. Painting will be done prior to well development. If specified in the Work Plan, a minimum 2-foot by 2-foot, 6 to 8-inch-thick concrete pad, sloped away from the well, will be constructed around the protective casing at the final ground level elevation. Three or four 2-inch-diameter or larger steel posts will be equally spaced around the well and embedded in separate concrete filled holes just outside of the concrete pad. The protective steel posts will extend approximately 1 foot above the well riser. Any well that is to be temporarily removed from service or left incomplete due to delay in construction, will be capped with a water tight cap and equipped with a "vandal-proof" cover satisfying applicable state or local regulations or recommendations.

#### 4. Documentation

Observations and data acquired in the field during drilling and installation of wells will be recorded to provide a permanent record. A boring log will be completed for each boring according to the procedures outlined in SOP No. 17 – Logging..

Additional documentation for well construction will be written in the field book according to SOP No. 8 – Field Reporting and Documentation and will include the following:

- Date
- Time
- Personnel
- Weather
- Subcontractors
- Health and Safety monitoring equipment and readings
- Grout, sand, and bentonite volume calculations prior to well installation
- The quantity and composition of the grout, seals, and filter pack actually used during construction

- Screen slot size (in inches), slot configuration, outside diameter, nominal inside diameter, schedule/thickness, composition, and manufacturer
- Coupling/joint design and composition
- Protective casing composition and nominal inside diameter
- Start and completion dates
- Discussion of all procedures and any problems encountered during drilling and well construction.

In addition, the well installation details will be shown in a diagram which will be drawn in the field book. Each well diagram will consist of the following (denoted in order of decreasing depth from ground surface):

- Reference elevation for all depth measurements
- Project and site names
- Well number
- Date(s) of installation
- The depth at which the hole diameter changes (if appropriate)
- The depth of the static water level and date of measurement(s)
- Total depth of completed well
- Depth of any grouting or sealing
- Nominal hole diameter(s)
- Amount of cement used for grouting or sealing
- Depth and type of well casing
- Description (to include length, internal, diameter, slot size, and material of well screen(s))
- Any sealing off of water-bearing strata
- Static water level upon completion of the well and after development

- Drilling date(s)
- Other construction details of monitoring well including grain size of well filter pack material and location of all seals and casing joints.

## 1. Objective

This document defines the standard Quality Assurance/Quality Control (QA/QC) samples. QA/QC samples are collected during field studies for various purposes which include the isolation of site effects (control samples), define background conditions (background sample), and evaluate field/laboratory variability (spikes and blanks, trip blanks, duplicate, split samples). This SOP is intended to be used together with several other SOPs. Applicable SOPs are listed below:

- SOP No. 8 - Field Reporting and Documentation
- SOP No. 11 - Groundwater Sampling
- SOP No. 18 - Low Flow Groundwater Purging and Sampling
- SOP No. 24 - Sample Classification, Packaging, and Shipping
- SOP No. 25 - Sample Containers, Preservation, and Holding Times
- SOP No. 26 - Sample Control and Custody Procedures
- SOP No. 28 - Soil Sampling
- SOP No. 31 - Surface Water Sampling
- SOP No. 32 – Sediment Sampling.

## 2. Equipment

The following equipment typically is required for this SOP:

- Waterproof coolers (hard plastic or metal)
- Custody Seals
- Field forms such as COC or sample collection sheet
- Field Notebook
- Ice
- Bubble Wrap
- Clear Tape
- Duct Tape
- Zip Loc Bags

- Sample Containers
- Waterproof Pen
- Permanent Marker.

### 3. QA/QC Samples

- Background Sample – a sample (usually a grab sample) collected from an area, water body, or site similar to the one being studied, but located in an area known or thought to be free from pollutants of concern.
- Split Sample – A sample, which has been portioned into two or more containers from a single sample container or sample mixing container. The primary purpose of a split sample is to measure sample handling variability. A split sample will also measure inter-or intra-laboratory precision.
- Duplicate Sample – Two or more samples collected in and representative of a given population. The purpose of a duplicate sample is to estimate the variability of a given characteristic or contaminant associated with a population.
- Trip Blanks – A sample, which is prepared by the laboratory prior to the sampling event in the actual container and is stored with the investigative samples throughout the sampling event. They are then packaged for shipment with the other samples and submitted for analysis. At no time after their preparation are trip blanks to be opened before they reach the laboratory. Trip blanks are used to determine if samples were contaminated during storage and/or transportation back to the laboratory (a measure of sample handling variability resulting in positive bias in contaminant concentration). If samples are to be shipped, trip blanks are to be provided with each shipment but not for each cooler.
- Spikes (also known as proficiency test (pt) samples) – A sample with known concentrations of contaminants. Spike samples are often packaged for shipment with other samples and sent for analysis. At no time after their preparation are the sample containers to be opened before they reach the laboratory. Spiked samples are normally sent with each shipment to contract laboratories only. Spiked samples are used to measure bias due to sample handling or analytical procedures.
- Equipment Field Blanks – a sample collected using organic-free water which has been run over/through sample collection equipment. These samples are used to determine if

contaminants have been introduced by contact of the sample medium with sampling equipment. Equipment field blanks are often associated with collecting rinse blanks of equipment that has been field cleaned.

- Temperature Blanks – A container of water shipped with each cooler of samples requiring preservation by cooling to 4°C (ice). The temperatures of the blanks are measured at the time of sample receipt by the laboratory. No temperature blank is necessary for samples designated as “waste”.
- Preservative Blanks – A sample that is prepared in the field and used to determine if the preservative used during field operations was contaminated, thereby causing a positive bias in the contaminant concentration. On studies of short duration, usually only a post-preservative blank is prepared at the end of all sampling activities. On studies extending beyond one week, a pre-preservative blank should also be prepared prior to beginning sampling activities. At the discretion of the project leader, additional preservative blanks can be prepared at intervals throughout the field investigation. These blanks are prepared by putting organic/analyte-free water in the container and then preserving the sample with the appropriate chemical.
- Field Blanks – A sample that is prepared in the field to evaluate the potential for contamination of a sample by site contaminants from a source not associated with the sample collected (for example air-borne dust or organic vapors which could contaminate a soil sample). Organic-free water is taken to the field in sealed containers or generated on-site. The water is poured into the appropriate sample containers at pre-designated locations at the site. Field blanks should be collected in dusty environments and/or from areas where volatile organic contamination is present in the atmosphere and originating from a source other than the source being sampled.
- Material Blanks – Samples of sampling materials (e.g., material used to collect wipe samples, etc.), construction materials (e.g., well construction materials), or reagents (e.g., organic/analyte free water generated in the field, water from local water supplies used to mix well grout, etc.) collected to measure any positive bias from sample handling variability. Commonly collected material blanks are listed below:
  - Wipe Sample Blanks – A sample of the material used for collecting wipe samples. The material is handled, packaged, and transported in the same manner as all other wipe

samples with the exception that it is not exposed to actual contact with the sample medium.

- Grout Blanks – a sample of the material used to make seals around the annular space in monitoring wells. Filter Pack Blanks -- a sample of the material used to create an interface around the screened interval of a monitoring well.
- Construction Water Blanks – a sample of the water used to mix or hydrate construction materials such as monitoring well grout.
- Organic/Analyte Free Water Blanks – a sample collected from a field organic/analyte free water generating system. The sample is normally collected at the end of sampling activities since the organic/analyte free water system is recharged prior to use on a study. On large studies, samples can be collected at intervals at the discretion of the project leader. The purpose of the organic/analyte free water blank is to measure positive bias from sample handling variability due to possible localized contamination of the organic/analyte free water generating system or contamination introduced to the sample containers during storage at the site. Organic/analyte free water blanks differ from field blanks in that the sample should be collected in as clean an area as possible (a usual location for the organic/analyte free water system) so that only the water generating system/containers are measured.
- Matrix Spike – A matrix spike is a known concentration of a target analyte(s) which is introduced into a second sample aliquot. The spiked sample is processed through the entire analytical procedure. Analysis of the matrix spike is used as an indicator of sample matrix effect on the recovery of target analyte(s).
- Matrix Spike Duplicate – A matrix spike duplicate is a known concentration (same as the matrix spike) of a target analyte(s) which is introduced into a third sample aliquot. The spiked sample is processed through the entire analytical procedure. Analysis of the matrix spike duplicate is used as an indicator of sample matrix effect on the recovery of target analyte(s) as well as method precision.

#### 4. *Sample Containers*

Certified commercially clean sample containers will be obtained from the contract analytical laboratory. The lab will indicate the type of sample to be collected in each bottle type. The work plan may list the appropriate sample containers for the specific analyses require for each project.

### 5. Sample Preservation

Samples will be preserved at the time of the sample collection. Chemical preservatives, if necessary, will be added to the sample containers either by the laboratory prior to shipment to the field, or in the field by sampling personnel.

After sample collection, each container will be labeled (see SOP No. 24) and stored on ice at 4°C in an insulated cooler until packed for shipment to the laboratory. The ice will be double bagged in Zip Loc storage bags. Freezing samples will not be permitted. Any breakable sample bottles need to be wrapped in protective packing material (bubble wrap) to prevent breakage during shipping.

### 6. QA/QC Sample Collection Frequency

QA/QC Sample	Frequency
Background Sample	Project Specific
Split Sample	Project Specific
Duplicate Sample	One per 10 samples collected per matrix
Trip Blank	One per cooler containing VOC samples
Spikes	Project Specific One per 20 samples collected per matrix
Equipment Field Blanks	One per 10 samples collected
Temperature Blanks	One per cooler
Preservative Blanks	Project Specific One post sampling – for projects less than one week. Two samples (one pre- and one post sampling) – for projects longer than one week.
Field Blanks	Project Specific One per 20 samples collected per matrix

Material Blanks	Project Specific One per matrix
Matrix Spike	One per 20 samples collected per matrix
Matrix Spike Duplicate	One per 20 samples collected per matrix

## 1. *Purpose and Scope*

This document defines the standard protocols for sample handling, documentation, and tracking. This SOP serves as a supplement to the Work Plan Addendum and Sampling and Analysis Plan Addendum and is intended to be used together with several other SOPs. Applicable SOPs are listed below:

- SOP No. 11 - Groundwater Sampling
- SOP No. 25 - Sample Containers, Preservation and Holding Times
- SOP No. 26 - Sample Control and Custody Procedures
- SOP No. 28 – Soil Sampling
- SOP No. 31 - Surface Water Sampling
- SOP No. 32 - Sediment Sampling.

## 2. *Procedures For Sample Identification, Handling, And Documentation*

### 2.1 Sample Identification

Samples collected during site activities shall have discrete sample identification numbers. These numbers are necessary to identify and track each of the many samples collected for analysis during the life of project. In addition, the sample identification numbers can be used in a database to identify and retrieve the analytical results received from the laboratory.

Each sample is identified by a unique code which indicates the site identification number, sample location number, sample matrix identifier, and sample depth. The sample locations will be numbered sequentially.

If used, sample matrix identifiers may include the following:

- SF - Direct-Push Soil Sample (Field Analysis)
- SL - Direct-Push Soil Sample (Laboratory Analysis)
- WF - Direct-Push Groundwater Sample (Field Analysis)
- SS - Soil Sample
- GW - Groundwater (from a Monitoring Well)
- SW - Surface Water Sample
- SD - Sediment Sample
- SL - Sludge or Sewer Sediment Sample

TB - Trip Blank

RN - Rinsate (Deionized Water)

An example of the sample identification number codes for a sewer sediment sample collected for field analysis will be: AUS-0A2B-004-SL-05.

Where AUS indicates Additional Uncharacterized Sites, 0A2B indicates the site location, 004 indicates the sample location, SL indicates the sample media, and 05 indicates the sampling interval.

The sampling locations, sample type, and sample sequence identifiers will be established prior to field activities for each sample to be collected. On-site personnel will obtain assistance from the Project Manager in defining any special sampling requirements.

## 2.2 Sample Labeling

Sample labels will be filled out as completely as possible by a designated member of the sampling team prior to beginning field sampling activities each day. The date, time, sampler's signature, and the last field of the sample identification number should not be completed until the time of sample collection. All sample labels shall be filled out using waterproof ink. At a minimum, each label shall contain the following information:

- Sampler's company affiliation
- Site location
- Sample identification code
- Date and time of sample collection
- Analyses required
- Method of preservation (if any) used
- Sample matrix (i.e., soil, groundwater, surface water)
- Sampler's signature or initials.

## 2.3 Sample Handling

This section discusses proper sample containers, preservatives, and handling and shipping procedures.

### *2.3.1 Sample Handling and Shipping*

After sample collection, each container will be labeled as described above, and then stored on ice at 4°C (+/- 2°C) in an insulated cooler until packed for shipment to the laboratory. The ice will be double bagged in Ziploc-type storage bags.

The sample containers will be placed in reclosable Ziploc plastic storage bags and wrapped in protective packing material (bubble wrap). Samples will then be placed right side up in a cooler with ice (double bagged using plastic bags), and taped with a custody seal for delivery to the laboratory. Samples will be hand delivered or shipped by overnight express carrier for delivery to the analytical laboratory. All samples must be shipped for laboratory receipt and analyses within specific holding times. This may require daily shipment of samples with short holding times. A chain-of-custody (COC) form will accompany each cooler. The temperature of all coolers will be measured upon receipt at the laboratory. A temperature blank will be included in each cooler for temperature measurement purposes.

### *2.4 Sample Documentation and Tracking*

This section describes documentation required in the field notes and on the sample Chain-of-Custody forms.

#### *2.4.1 Field Notes*

Documentation of observations and data acquired in the field will provide information on the acquisition of samples and also provide a permanent record of field activities. The observations and data will be recorded using pens with permanent waterproof ink in a permanently bound weatherproof field log book containing consecutively numbered pages.

The information in the field book will include the following as a minimum. Additional information is included in the specific SOPs regarding the field books.

- Project name
- Location of sample
- Sampler's printed name and signature
- Date and time of sample collection
- Sample identification code including QC and QA identification
- Description of samples (matrix sampled)
- Sample depth (if applicable)

- Number and volume of samples
- Sampling methods or reference to the appropriate SOP
- Sample handling, including filtration and preservation, as appropriate for separate sample aliquots
- Analytes of interest
- Field observations
- Results of any field measurements, such as depth to water, pH, temperature, and conductivity
- Personnel present
- Level of PPE used during sampling.

Changes or deletions in the field book should be lined out with a single strike mark, initialed, and remain legible. Sufficient information should be recorded to allow the sampling event to be reconstructed without relying on the sampler's memory.

Each page in the field books will be signed by the person making the entry at the end of the day, as well as on the bottom of each page. Anyone making entries in another person's field book will sign and date those entries.

#### *2.4.2 Sample Chain-of-Custody*

During field sampling activities, traceability of the sample must be maintained from the time the samples are collected until laboratory data are issued. Initial information concerning collection of the samples will be recorded in the field log book as described above. Information on the custody, transfer, handling, and shipping of samples will be recorded on a COC form. The COC is a three-part carbonless form.

The sampler will be responsible for initiating and filling out the COC form. The COC will be signed by the sampler when the sampler relinquishes the samples to anyone else. One COC form will be completed for each cooler of samples collected daily. The COC will contain the following information:

- Sampler's signature and company affiliation
- Project number
- Date and time of collection
- Sample identification number

- Sample type
- Analyses requested
- Number of containers
- Signature of persons relinquishing custody, dates, and times
- Signature of persons accepting custody, dates, and times
- Method of shipment
- Shipping air bill number (if appropriate).

The person responsible for delivery of the samples to the laboratory will sign the COC form, retain the last copy of the three-part COC form, document the method of shipment, and send the original and the second copy of the COC form with the samples. Upon receipt at the laboratory, the person receiving the samples will sign the COC form and return the second copy to the Project Manager. Copies of the COC forms documenting custody changes and all custody documentation will be received and kept in the central files. The original COC forms will remain with the samples until final disposition of the samples by the laboratory. The analytical laboratory will dispose of the samples in an appropriate manner 60 to 90 days after data reporting. After sample disposal, a copy of the original COC will be sent to the Project Manager by the analytical laboratory to be incorporated into the central files.

## 1. Objective

This document defines the standard protocols for sample handling, documentation, and tracking. This SOP is intended to be used together with several other SOPs. Applicable SOPs are listed below:

- SOP No. 8 – Field Reporting and Documentation
- SOP No. 11 – Groundwater Sampling
- SOP No. 18 – Low Flow Groundwater Purging and Sampling
- SOP No. 23 – Quality Assurance Samples
- SOP No. 24 – Sample Classification, Packaging, and Shipping
- SOP No. 26 – Sample Control and Custody Procedures
- SOP No. 28 – Soil Sampling
- SOP No. 31 – Surface Water Sampling
- SOP No. 32 – Sediment Sampling.

## 2. Equipment

The following equipment will be required for this SOP:

- Waterproof coolers (hard plastic or metal)
- Custody Seals
- Field forms such as COC or sample collection sheet
- Field Notebook
- Ice
- Bubble Wrap
- Clear Tape
- Duct Tape
- Zip Loc Bags
- Sample Containers

- Waterproof Pen
- Permanent Marker.

### 3. *Sample Containers*

Certified commercially clean sample containers will be obtained from the contract analytical laboratory. The lab will indicate the type of sample to be collected in each bottle type. The work plan may list the appropriate sample containers for the specific analyses required for each project.

### 4. *Sample Preservation*

Samples will be preserved at the time of the sample collection. Chemical preservatives, if necessary, will be added to the sample containers either by the laboratory prior to shipment to the field, or in the field by sampling personnel.

After sample collection, each container will be labeled (see SOP No. 24) and stored on ice at 4°C (+/- 2°C) in an insulated cooler until packed for shipment to the laboratory. The ice will be double bagged in Zip Loc storage bags. Freezing samples will not be permitted. Any breakable sample bottles need to be wrapped in protective packing material (i.e., bubble wrap) to prevent breakage during shipping.

### 5. *Sample Hold Times*

Samples will be hand delivered or shipped via overnight express carrier for delivery to the analytical laboratory. All samples must be shipped for laboratory receipt and analyses within specific holding times. This may require daily shipment of samples with short holding times. The hold time varies for each type of analysis, therefore, it will be necessary to check with the lab to verify the hold times to determine how frequently samples need to be sent to the lab. Typical hold times are provided in Table 1.

Documentation of observations and data acquired in the field will provide information on the acquisition of samples and also provide a permanent record of field activities. The observations and data will be recorded using pens with permanent waterproof ink in a permanently bound weatherproof field log book containing consecutively numbered pages. Documentation for the sample containers, preservation, and hold times is outlined in SOP No. 8 Field Reporting and Documentation.

**Table 1**  
**SOP No. 25**  
**Sample Containers, Preservatives, and Holding Times**  
**Typical Sample Hold Times**

<b>Analysis</b>	<b>Holding Time</b>	<b>Preservation</b>
% Lipids	NA	Freeze
Alkalinity	14 days	Cool to 4°C
Ammonia NH <sub>3</sub>	28 days	Cool to 4°C - H <sub>2</sub> SO <sub>4</sub> to pH<2
Asbestos	1 year	None
BOD 5	48 hours	Cool to 4°C
BOD 5 Inhibited	48 hours	Cool to 4°C
BTEX	14 days	Cool to 4°C; HCl
Chloride	28 days	Cool to 4°C
Chlorophyll	24 hrs to filtration - 28 days after filtration	Freeze filters in 90% acetone
Chromium VI (Hexavalent) in water	24 hours	Cool to 4°C
COD	28 days	Cool to 4°C - H <sub>2</sub> SO <sub>4</sub> to pH<2
Coliform (fecal and total)	6 hours	Cool to 4°C; 0.008% Sodium Thiosulfate
Conductivity	28 days	Cool to 4°C
Cyanide in Soil	14 days	Cool to 4°C
Cyanide in Water	14 days	Cool to 4°C NaOH to pH>12; 0.6 g ascorbic acid
Enterococci	6 hours	Cool to 4°C; 0.008% Sodium Thiosulfate
Fecal Streptococcus	6 hours	Cool to 4°C; 0.008% Sodium Thiosulfate
Fluoride in Soil	28 days	Cool to 4°C
Fluoride in Water	28 days	Cool to 4°C
Grain Size Sediment	6 months	None required
Guaiacols/Catechols/Phenols	30 days	Cool to 4°C; H <sub>2</sub> SO <sub>4</sub> to pH<2
Halogenated Hydrocarbons HH	7 days water/14 days soil	Cool to 4°C
Hardness	6 months	HNO <sub>3</sub> to pH<2
Herbicides	7 days water/14 days soil	Cool to 4°C
Hydrocarbon chlorinated	7 days water/14 days soil	Cool to 4°C Ascorbic acid
Ignitability	None	Cool to 4°C

**Table 1**  
**SOP No. 25**  
**Sample Containers, Preservatives, and Holding Times**  
**Typical Sample Hold Times**

<b>Analysis</b>	<b>Holding Time</b>	<b>Preservation</b>
Iron and sulfur bacteria	6 hours	Cool to 4°C; 0.008% Sodium Thiosulfate
Klebsiella	6 hours	Cool to 4°C; 0.008% Sodium Thiosulfate
Mercury in Water	28 days	Cool to 4°C; HNO <sub>3</sub> to pH<2
Metals -- Except Cr(6) and Hg	180 days	HNO <sub>3</sub> to pH <2
Metals dissolved	6 months	Filter - then add HNO <sub>3</sub> to pH<2
Nitrate NO <sub>3</sub> -	48 hours	Cool to 4°C
Nitrate-Nitrite	28 days	Cool to 4°C; H <sub>2</sub> SO <sub>4</sub> to pH<2
Nitrite NO <sub>2</sub> -	48 hours	Cool to 4°C
Nitrogen Pesticides	7 days water/14 days soil	Cool to 4°C
NWTPH-Dx and NWTPH-HCID	7 days water/14 days soil	Cool to 4°C HCl to pH<2
NWTPH-Gx	14/14 days	Cool to 4°C HCl to pH<2
Oil & Grease in Water	28 days	Cool to 4°C; HCl to pH<2
Oil and Grease in Soil	28 days	Cool to 4°C
Organic Screen (PAH Phenolics Creosote etc.)	7 days water/14 days soil	Cool to 4°C
Organophosphorus pesticides	7 days water/14 days soil	Cool to 4°C
Ortho Phosphate PO <sub>4</sub> <sup>3-</sup>	48 hours	Filter; Cool to 4°C
PAH Hazardous Waste Designation w/o HPLC	7 days water/14 days soil	Cool to 4°C
PAH Polynuclear Aromatic Hydrocarbons	7 days water/14 days soil	Cool to 4°C
PCBs only	7 days water/14 days soil	Cool to 4°C
Percent Solids Soil/Tissue	7 days	Cool to 4°C
Personal Monitors	None	None

**Table 1**  
**SOP No. 25**  
**Sample Containers, Preservatives, and Holding Times**  
**Typical Sample Hold Times**

<b>Analysis</b>	<b>Holding Time</b>	<b>Preservation</b>
Pesticides/PCBs	7 days water/14 days soil	Cool to 4°C
pH	24 hours	Cool to 4°C
Phenolics in Soil (4AAP)	28 days	Cool to 4°C
Phenolics in Water (4AAP)	28 days	Cool to 4°C; H <sub>3</sub> PO <sub>4</sub> ; FeSO <sub>4</sub> and CuSO <sub>4</sub>
PM10	1 year	Cool to 4°C
PM2.5	30 days	Cool to 4°C
Resin/Fatty acids	30 days	Cool to 4°C NaOH to pH>10
Semivolatiles BNA	7 days water/14 days soil	Cool to 4°C
Settleable Solids(SS)	48 hours	Cool to 4°C
Specific conductance	28 days	Cool to 4°C
Sulfate	28 days	Cool to 4°C
Sulfide	7 days	Zinc acetate; NaOH to pH>9
TOC in Soil	28 days <sup>5</sup>	Cool to 4°C
TOC in Water	28 days	Cool to 4°C; H <sub>2</sub> SO <sub>4</sub> to pH<2
Total Dissolved Solids(TDS)	7 days	Cool to 4°C
Total Kjeldahl Nitrogen (TKN)	28 days	Cool to 4°C; H <sub>2</sub> SO <sub>4</sub> to pH<2
Total Non-Volatile Solids(TNVS)	7 days	Cool to 4°C
Total Non-Volatile Suspended Solids(TNVSS)	7 days	Cool to 4°C
Total Persulfate Nitrogen (TPN)	28 days	Cool to 4°C; H <sub>2</sub> SO <sub>4</sub> to pH<2
Total Phosphorus (TP)	28 days	Cool to 4°C; H <sub>2</sub> SO <sub>4</sub> to pH<2
Total Solids(TS)	7 days	Cool to 4°C
Total Suspended (TSS)	7 days	Cool to 4°C
Total Volatile Solids(TVS)	7 days	Cool to 4°C
Tributyl tin	7 days water/14 days soil	Cool to 4°C
Turbidity	48 hours	Cool to 4°C

**Table 1**  
**SOP No. 25**  
**Sample Containers, Preservatives, and Holding Times**  
**Typical Sample Hold Times**

<b>Analysis</b>	<b>Holding Time</b>	<b>Preservation</b>
VOA Air Toxics	none	Room temperature
Volatile Organics/VOA	7 days water/14 days soil	Cool to 4°C HCl -- ascorbic acid

### 1. Objective

This document defines the standard procedure for the control and custody of environmental samples. This SOP is intended to be used together with several other SOPs. Applicable SOPs are listed below:

- SOP No. 8 - Field Reporting and Documentation
- SOP No. 11 - Groundwater Sampling
- SOP No. 24 - Sample Classification, Packaging, and Shipping
- SOP No. 25 - Sample Containers, Preservation, and Holding Times
- SOP No. 28 - Soil Sampling
- SOP No. 31 - Surface Water Sampling
- SOP No. 32 - Sediment Sampling.

### 2. Equipment

The following equipment will be needed for sample control and custody procedures:

- Waterproof coolers (hard plastic or metal)
- Custody Seals
- Field forms such as a Chain of Custody (COC) or sample collection sheet
- Field Notebook
- Ice
- Sample Log-in Book
- Clear Tape
- Duct Tape
- Zip-Loc Bags
- Waterproof pens
- Permanent Markers.

### 3. Sample Control and Custody Procedures

Once the samples are collected, they must remain in the custody of the sampler or another worker from the site. The samples can also remain unattended in a locked vehicle or jobsite

trailer so tampering with the samples will not be possible. Right before shipment, a custody seal should be placed over the opening of the cooler and then the cooler should be taped all the way around with clear packing tape to prevent tampering with the samples. Samples will be hand delivered or shipped via overnight express carrier for delivery to the analytical laboratory (see SOP No. 24). All samples must be shipped for laboratory receipt and analyses within specific holding times. This may require daily shipment of samples with short holding times. Each cooler will contain a chain of custody (COC) form.

During field sampling activities, traceability of the samples must be maintained from the time the samples are collected until the laboratory data is issued. Initial information concerning the collection of the samples will be recorded in the field log book as outlined in SOP No. 8 – Field Reporting and Documentation. Information on the custody, transfer, handling, and shipping of samples will be recorded on a COC form. If the COC is not three-part (minimum) carbon-copy form, then photocopy the COC after signatures have been obtained, before the samples and original copy leave the site. An example COC form is attached to this procedure.

The sampler will be responsible for initiating and filling out the COC form. The COC will be signed by the sampler or the field person responsible for sample handling when the sampler relinquishes the samples to anyone else. One COC form will be completed for each cooler of samples collected daily and if samples are not hand delivered, the COC will be placed in a Zip-Loc bag and shipped inside the cooler. COC forms will be used to document the transport and receipt of samples from the field to the lab. Information required on a COC includes the following:

- Samplers signature and affiliation
- Project Number
- Date and time of collection
- Sample identification number
- Sample Type
- Analyses requested.
- The total number of containers being sent to the lab for each sample
- The appropriate preservative used
- If any samples are to be placed on hold at the laboratory, this should be clearly indicated on the COC in the comments section

- Signature of person(s) relinquishing custody, dates, and times
- Signature of person(s) accepting custody, dates, and times
- Method of shipment
- Shipping air bill number (if appropriate).

The person responsible for delivery of the samples to the laboratory will sign the COC form, retain the last copy of the three-part COC form, document the method of shipment, and send the original and the second copy of the COC form with the samples. Upon receipt at the laboratory, the person receiving the samples will sign the COC form. The original COC will remain with the samples until final disposition of the samples by the laboratory. The laboratory will dispose of the samples in an appropriate manner 60 to 90 days after data reporting.



## 1. Objective

This document defines the standard procedure for collection of soil samples for environmental characterization purposes. This procedure provides descriptions of equipment and field procedures necessary to collect soil samples. Other related SOPs are listed below:

- SOP No. 4 – Decontamination
- SOP No. 8 – Field Reporting and Documentation
- SOP No. 14 - Headspace Soil Screening
- SOP No. 24 – Sample Classification, Packaging and Shipping
- SOP No. 25 – Sample Containers, Preservation, and Holding Times
- SOP No. 26 – Sample Control and Custody Procedures.

## 2. Equipment

The following equipment is typically used to collect soil samples:

- Hand Auger (if required to collect sample)
- Latex/Nitrile gloves
- Organic Vapor meter (e.g. PID, OVA)
- Surveyor's stakes
- Portable field table
- Stainless steel pans and knives
- Stainless steel spoon or scoop
- Stainless steel bowl
- Sample containers
- Decontamination equipment
- Plastic Sheeting

- Field data sheets/bound field logbook
- Health & Safety equipment
- Cooler with ice.

### 3. *Soil Sample Collection Procedures*

This section provides step-by-step procedures for collecting soil samples in the field. Observations made during soil sample collection should be recorded in a bound field logbook in accordance with the procedures defined in SOP No. 8 on field reporting and documentation:

- A. Remove appropriate sample containers from the transport container, and prepare the sample containers for receiving samples.
- B. Fill out a self-adhesive label with the appropriate information and affix it to the appropriate sample container. Place clear polyethylene tape over the completed label to protect it from dirt and water (unless a tare weight has been recorded by the lab on the container). Sample labels can be prepared prior to sample collection except for time and date. Labels can be filled in on the date and time of sample collection just prior to collecting the sample. Sample containers will be kept cool with their caps on until they are ready to receive samples.
- C. Place labeled sample containers near the sampling location.
- D. Place clean plastic sheeting on the ground surface at the sampling area as needed.
- E. Put on a pair of new nitrile or latex gloves.
- F. Decontaminate the sampling equipment as described in detail in SOP No. 4 prior to beginning sampling activities.
- G. Advance the sampler (direct push sampler, hand auger, split-spoon, etc.) to the desired sample depth and retrieve the sample.
- H. VOC samples cannot be composited without losing volatiles. Therefore, collect a discrete VOC sample prior to compositing the remaining soil (if doing so). Collect the VOC sample with an EnCore™ or Terra Core sampler, or by placing it directly into an appropriate sample container. If the sample is transferred to a jar, the entire jar must be filled without any voids and the top surface of the soil should be smeared to prevent VOCs from escaping when opening the jar. After collecting the sample at the desired location within the sample interval, place the remainder of the sample into a stainless

steel bowl/Ziploc bag, break up large chunks and mix the soil. Fill the remaining sample containers from the steel bowl.

- I. Place the sample containers on ice in a cooler to maintain the samples at approximately 4°C as described in SOP No. 25. Ship the cooler to the laboratory for analysis within 24 hours of sample collection in accordance with the procedures described in SOP No. 24.
  - J. Begin chain-of-custody procedures. A sample chain-of-custody form is included in SOP No. 26.
  - K. Decontaminate the sample equipment as described in detail in SOP No. 4.
  - L. Field notes shall be kept in a bound field logbook.
4. *Possible Soil Sample Collection Methods*
- A. Geoprobe (micro or macro samplers)
  - B. Split Spoon sampler using a conventional drill rig
  - C. Hand Auger
  - D. Surface Sampling with a stainless steel spoon or scoop.

## 1. Objective

This document defines the standard operating procedure (SOP) and necessary equipment for the sampling with the use a hydraulically advanced GeoProbe® (or similar) to obtain representative subsurface soil samples for geologic logging and physical and chemical laboratory testing.

SOPs providing additional related guidance are listed below:

- SOP No. 4 – Decontamination
- SOP No. 8 – Field Reporting and Documentation
- SOP No. 17 – Logging
- SOP No. 24 – Sample Classification, Packaging and Shipping
- SOP No. 25 – Sample Containers, Preservation, and Holding Times
- SOP No. 26 – Sample Control and Custody Procedures.
- SOP No. 28 – Soil Sampling.

## 2. Equipment

The following equipment is typically required:

- Hydraulic percussion hammer Geoprobe®
- 1 inch diameter by 3 foot length steel probe rods
- Barrel sampler - 2 1/4 in diameter by 4 ft length
- Acetate liners
- Disposable sample retainers
- Photoionization detector (OVM, Hnu)
- Surveyor's stakes
- Stainless steel pans, knives and resealable plastic bags
- Sample containers
- Decontamination equipment.

### 3. Procedure

The general procedure for using the Geoprobe<sup>®</sup> equipment for sampling is as follows. The specific soil probe operation procedures may vary slightly based on individual drilling contractors' SOPs for soil probe operation:

- A. Locate boring using facility drawings to check utilities
- B. Log boring location on site base map
- C. Hydraulically push or drive 1 in. diameter probe rods with acetate sample liner attached, or dual tube system with acetate liner to the first sample depth
- D. Remove probe/inner rods and retrieve acetate liner. Visually log and classify the soil, select specimen for physical and/or chemical testing. Record information on field data sheets
- E. Replace sampler acetate liner
- F. Measure VOC concentrations with PID at top of probe hole prior to sampling the next depth interval (if VOCs are a concern)
- G. Insert acetate sample liner and attached rods in exiting probe hole and push or drive sampler to the next sample depth, repeat sampling procedure
- H. Repeat Geoprobe<sup>®</sup> sampling until the target depth is reached
- I. Record total depth
- J. Retrieve probe rods
- K. Backfill probe hole with bentonite or similar as required by the work plan
- L. Place survey stake at boring location
- M. Record data collected on boring log and log book
- N. Decontaminate equipment.

### 4. Decontamination

Refer to the HSP for personnel decontamination procedures; refer to SOP 4 for equipment decontamination procedures.

## 1. Purpose and Scope

This Standard Operating Procedure (SOP) describes the standard protocols for operating, calibrating, and maintaining equipment commonly used during water quality monitoring. This SOP also defines the documentation necessary when using this equipment.

This SOP serves as a supplement to the Work Plan and is intended to be used together with other SOPs. Other related SOPs are listed below:

- SOP No. 11 – Groundwater Sampling
- SOP No. 18 – Low Flow Groundwater Purging and Sampling
- SOP No. 31 – Surface Water Sampling
- SOP No. 42 – Groundwater Profiling.

Health and safety procedures and equipment that will be required during the investigation are detailed in the HSP.

## 2. Water Quality Monitoring Procedures

### 2.1 Equipment List

Equipment used for monitoring water quality parameters is as follows:

- Water Quality Parameter Instrument – measures pH, temperature, conductivity turbidity, dissolved oxygen and/or oxidation-reduction potential
- Other water quality monitoring devices (if necessary)
- Distilled water
- Dry, clean paper towels
- Latex gloves
- Field log book
- Manufacturer's guide for each meter used
- Calibration fluids.

### 2.2 Calibration Procedure

The following are general calibration procedures:

- Field instruments will be checked and calibrated prior to their use on site. Batteries will be charged and checked daily where applicable.

- Equipment that fails calibration and/or becomes otherwise inoperable during the field investigation will be removed from service and segregated to prevent inadvertent use. Such equipment will be properly tagged to indicate that it should not be used until the nature of the problem can be determined.
- Equipment requiring repair or recalibration must be approved for use by the site manager or Site Health and Safety Officer prior to placement back into service. Equipment that cannot be repaired or recalibrated will be replaced.

Calibration of the Water Quality Parameter Instrument should be performed per the manufacturer's specific instructions. In general, calibration is done by adjusting the meter with standard buffer solution(s).

### 2.3 Operating Procedures

Operation of the Water Quality Parameter Instrument will be done in accordance with the manufacturer's specific instructions. Generally, operating procedures are as follows:

1. Turn on instrument, clear instrument.
2. If using a flow-through cell, allow the water to flow through the cell and record readings as indicated in the work plan and go to Step 9. If not using a flow-through cell, go to Step 3.
3. Rinse the sample cup with distilled water and fill with sample water.
4. Rinse the probes with distilled water. Blot excess.
5. Immerse the probes in the sample and swirl gently, keeping the probes in the sample until the display stops flashing or readings have generally stabilized.
6. Record the water quality parameters of the sample after stabilization. Note any problems such as meter drift.
7. Rinse the probes with distilled water. Blot excess.
8. Repeat steps 3-7 for additional samples.
9. When finished, rinse the probes and sample cup/flow-through cell with distilled water and turn off instrument.

\*\*\*\*\*

Note: degrees C = (degrees F - 32) (5/9)  
degrees F = ((9/5)C degrees) + 32

\*\*\*\*\*

### Maintenance

- All field instrumentation, sampling equipment, and accessories will be maintained in accordance with the manufacturer's recommendations and specifications and established field practice.
- All maintenance will be performed by qualified project personnel and will be documented by the appointed equipment manager or designee under the direction of the equipment manager.
- All field instruments will be properly protected against inclement weather conditions during the field investigation. Each instrument is specially designed to maintain its operating integrity during variable temperature ranges that are representative of ranges that will be encountered during expected working conditions.
- At the end of each working day, all field equipment will be taken out of the field and placed in a dry room for overnight storage.

#### 2.4 *Sample Identification, Handling, and Documentation*

Samples will be identified, handled, and recorded as described in this SOP and in SOP No. 7, SOP No. 25 and SOP No. 26.

### *Documentation*

The following information should be recorded in the field log book:

- Calibration of equipment will be recorded in the field logbook to document that appropriate procedures have been followed.
- Calibration will also be recorded on a calibration log. Entries made on the equipment calibration log regarding the status of any field equipment will contain, but are not necessarily limited to, the following information:
  1. Date and time of calibration
  2. Name of person doing calibration
  3. Type of equipment being serviced, and identification number (such as serial number)
  4. Reference standard used for calibration (such as pH of buffer solutions)
  5. Calibration and/or maintenance procedure used
  6. Any problems or other pertinent information.

- Each reading taken for a particular sample will be recorded in the field logbook and on a field form. Entries will include, but are not limited to the following:
  1. Date and time of reading
  2. Type of reading
  3. Value of reading with units
  4. Any problems or other pertinent information.

## 1. Objective

This document defines the standard operating procedure (SOP) and necessary equipment for collection of groundwater profiling samples within hydraulically advanced GeoProbe® (or similar) hollow drill rods and well screens using a peristaltic pump or ball and check valve.

During groundwater profiling activities, groundwater samples are collected at predetermined intervals from the top of the uppermost aquifer to the base of the lower aquifer. Sampling intervals are specified in the Scope of Work for a specific site. Groundwater samples are collected by using a GeoProbe® to hydraulically advance a 4-foot stainless steel slotted sampler with a screen slot size of 0.002 inches to pre-determined intervals below ground surface. In this technique, in order to lessen drawdown within the hollow drill rods, a pump that minimizes disturbance to the groundwater is operated at the lowest possible flow rate. Purging is performed until specific parameters have stabilized as specified in the Work Plan over three consecutive flow-through cell volumes or until one hour of purge time has elapsed, whichever occurs first. Therefore, the groundwater samples collected are representative of the water bearing formation and hydraulically isolated from the water in the casing.

SOPs providing additional related guidance are listed below:

- SOP No. 4 – Decontamination
- SOP No. 8 – Field Reporting and Documentation
- SOP No. 10 – Groundwater Level Measurements
- SOP No. 18 – Low-Flow Groundwater Purging and Sampling
- SOP No. 20 – Monitoring Well Development and Purging
- SOP No. 24 – Sample Classification, Packaging and Shipping
- SOP No. 25 – Sample Containers, Preservation, and Holding Times
- SOP No. 26 – Sample Control and Custody Procedures.

## 2. Equipment

Equipment used during well purging and sampling:

- Polyethylene tubing
- Ball and check valve
- Disposable latex or nitrile gloves

- Assorted tools (knife, screwdriver, etc.)
- Pump and required accessories (described in more detail in following section)
- Electronic water level indicator with 0.01-foot increments
- Graduated cylinder
- Temperature meter
- pH meter (with automatic temperature compensation)
- Conductivity meter
- Turbidity meter
- Dissolved oxygen (DO) meter
- Oxidation reduction potential (ORP) meter
- Flow-through cell
- Calibration fluids
- Paper towels or Kimwipes
- Calculator
- Bound field logbook (logbook)
- Waterproof pen and permanent marker
- Plastic buckets
- 55-gallon drums or truck-mounted tank
- Plastic sheeting
- Appropriate decontamination equipment (see SOP No. 4)
- Cooler with ice
- Sample containers and labels
- Groundwater sampling form
- Chain-of-Custody form
- Appropriate health and safety equipment (e.g., photoionization detector (PID)).

### 3. Sampling Procedure

This section provides the step-by-step procedure for collecting groundwater profile samples in the field. Observations made during groundwater purging and sampling should be recorded in a logbook in accordance with procedures described in SOP No. 8.

- A. Any equipment used in the profile sampling procedure that could contact groundwater should be properly decontaminated before each use (see SOP No.4).
- B. Equipment should be calibrated based on the manufacturers' instructions. The frequency of calibration should be specified in the site-specific Field Sampling Plan (FSP), Quality Assurance Project Plan (QAPP) or work plan. Dissolved oxygen calibration must be corrected for local barometric pressure readings and elevation.
- C. Underground utilities at the location of each soil probe will be cleared prior to commencement of probing activities. Following utility clearance the 4-foot sampler will be advanced to the predetermined depth and opened. A groundwater measurement of the water within the screen and rods will be collected to the nearest 1/100<sup>th</sup> of a foot. Measurements will be recorded in the logbook and any pertinent field forms. The volume of water within the screen and rods will then be calculated.
- D. Following measurement of the static groundwater elevation, the appropriate equipment will be slowly and carefully placed in the rods. If the rods have light or dense non-aqueous-phase liquids (LNAPLs or DNAPLs) care should be taken to place sampling equipment below or above the NAPL.

When placing the equipment in the well, the pump intake should be set near the middle or slightly above the middle of the screened interval. If the screen length allows, the pump intake should be at least two feet from the bottom of the screen. Placing the pump intake near the top of the water column can cause stagnant water from the casing to be purged, but placing the pump intake near to the bottom of the well can cause mobilization and entrainment of settled solids from the bottom of the well.

- E. Tubing should be connected from the pump to a flow-through cell. New tubing should be used for each profiling interval.
- F. The pump should be started at a low flow rate, approximately 100 mL/min or the lowest flow rate possible.

G. In most cases, purging will continue until specific parameters have stabilized over three consecutive flow-through cell volumes. **Table 1** provides guidelines that may be used for parameter stabilization as specified by USEPA, ASTM, and in the Nielsen and Nielsen Technical Guidance on Low-Flow Purging and Sampling and Minimum-Purge Sampling (Nielsen and Nielsen, 2002). These guidelines are to be used in combination with professional judgment.

**Table 1. Stabilization Guidelines for Low-Flow Sampling**

Parameter	Stabilization Guidelines		
	EPA	ASTM	Nielsen & Nielsen
DO	+/- 10%	+/- 10% or +/-0.2 mg/L, whichever is greatest	+/- 10% or +/-0.2 mg/L, whichever is greatest
ORP	+/- 10 mV	+/- 20 mV	+/- 20 mV
PH	+/- 0.1 units	+/- 0.2 units	+/- 0.2 units
Conductivity	+/- 3%	+/- 3%	+/- 3%
Temperature	Not Specified	Not Specified	+/- 0.2 °C
Turbidity	+/- 10%	Not Specified	Not Specified

H. After the relevant parameters have stabilized or the required purging time has elapsed, the flow-through cell should be disconnected or bypassed for sampling. Samples will be collected by allowing the groundwater to flow from the tubing directly into the laboratory supplied containers.

I. A new pair of disposable latex or nitrile gloves should be put on immediately before sampling.

J. The constituents should be sampled for in the order given below:

- VOCs – Vials should be filled completely so that the water forms a convex meniscus then capped so that no air space exists in the vial. Turn the vial over and tap it to check for bubbles. If air bubbles are observed in the sample vial, remove the lid and attempt to fill the vial two more times, (being careful not to dump out any

groundwater currently in the vial). If air bubbles are present twice more, discard the sample vial and repeat the procedure with a new vial. If, after three attempts, air bubbles are still in the vial, make a note of this and place the vial in the cooler.

- Gas sensitive parameters (e.g., ferrous iron, methane, alkalinity)
- Semivolatile organic compounds, pesticides, polychlorinated biphenyls, and herbicides
- Petroleum hydrocarbons
- Metals (unfiltered)
- Explosives
- Any filtered analytes (use in-line filters if possible).

K. Place all samples on ice inside a cooler immediately.

L. Each sample should be identified with the Sample ID, location, analysis number, preservatives, date and time of sampling event, and sampler.

M. The sample time and constituents to be analyzed for should be recorded in the logbook and on the groundwater sampling form.

N. Chain-of-custody procedures should be started.

O. Sample equipment should be decontaminated or replaced as applicable.

P. The GeoProbe® sampler should then be advanced to the next predetermined profiling depth and the process of purging and sampling repeated.

Q. Upon completion of each alluvial aquifer boring, each GeoProbe® hole will be sealed with grout from the bottom up using the GeoProbe® rods as a tremie pipe and the surface will be returned to the original condition. Purge water will be placed in 55-gallon drums (or similar) that are labeled, sealed, and staged at a pre-determined location on-site. The GeoProbe® unit and rods will be cleaned between profiling holes using a steam pressure washer. Wash water will be containerized in 55-gallon drums (or similar) and labeled.

4. *List of Potential Suppliers Who Provide Pumps Suitable for Groundwater Profile Sampling*

Field Environmental. 1-800-3930-4009. [www.fieldenvironmental.com](http://www.fieldenvironmental.com). Pumps: peristaltic, QED bladder pumps, Fultz rotor pump, control boxes, compressors, etc.

QED. 1-800-624-2026. [www.micropurge.com](http://www.micropurge.com). Pumps: bladder pumps, flow cell, compressors, etc.

Fultz Pumps. 1-717-248-2300. [www.fultzpumps.com](http://www.fultzpumps.com).

## 1. Objective

This document defines the standard operating procedure (SOP) and necessary equipment for collection of soil vapor samples from vapor monitoring points or temporary Geoprobe® sampling points using summa canisters. Tedlar bags are not a recommended means to collect soil vapor samples to be run at a fixed laboratory.

SOPs providing additional related guidance are listed below:

- SOP No. 3 – Calibration and maintenance of Field Instruments
- SOP No. 4 – Decontamination
- SOP No. 8 – Field Reporting and Documentation.
- SOP No. 24 – Sample Classification, Packaging and Shipping (DOT)
- SOP No. 25 – Sample Containers, Preservation, and Holding Times
- SOP No. 26 – Sample Control and Custody Procedures.

## 2. Equipment

Personnel implementing this guideline must ensure that the following are in place:

- Field book
- Disposable nitrile gloves
- Ultra-fine permanent marker
- Paper towels or Kimwipes
- Calculator
- Decontamination equipment
- Soil vapor sampling logs
- Small brush or broom
- Plastic sheeting
- Sterile syringe with valve connection
- Peristaltic pump
- Rotometer or equivalent
- Manometer
- PID or FID

- 4-gas meter (e.g., QRAE, Firstcheck+)
- Summa canisters with flow controllers (supplied by the laboratory)
- Tedlar bags
- Swagelok connectors
- Teflon tubing (food- or laboratory-grade)
- Polyethylene tubing (food- or laboratory-grade)
- Watch or timer
- Standard field tools (e.g., ratchet set, safety cutting tools, pry bar, etc.)
- Shipping supplies (e.g., UN boxes, shipping labels, hazard labels, packing tape)

### 3. *Sampling*

1. Open vapor point to check integrity of individual soil vapor monitoring port(s) (VMP).
2. Attach the pressure gauge provided by the laboratory to the Summa canister inlet, open valve completely, record reading, close valve completely, and remove the pressure gauge. Use the same gauge for the entire set of canisters to ensure data comparability. The canister should show a vacuum of approximately 28 inches of mercury (Hg). If the canister does not show a vacuum of at least 24 inches of Hg, mark canister as a potential leaker and discard the canister, then replace it with another canister.
3. Attach flow controller (one for each Summa canister) provided by the laboratory to the Summa canister inlet. **If possible, do not reuse flow controllers** between locations. Each flow controller is pre-set by the laboratory to collect the sample over a half-hour period. Flow controllers can be set to a different rate if desired by project, depending on size of container to be filled. For a 1-Liter Summa canister, a half-hour is a standard collection time (~33 ml/min).
4. If flow controller has a built in pressure gauge, attach separate pressure gauge provided by the laboratory to the inlet. Open valve completely. After 60 seconds, if gauges do not match, note in field book. If gauge readings are significantly different (greater than 5 inches of Hg) mark the flow controller as faulty and discard, then replace it with another. This method constitutes a leak check for Method TO-15.
5. Connect digital manometer or other  $\Delta P$  measurement device to the VMP. Open VMP and record vacuum pressure once stable. Allow up to 15 minutes for reading to stabilize.

6. Purge 3 volumes from VMP using syringe or other manual pump. If syringe or pump pulls back and purge cannot be completed, the VMP screen may be saturated with water and will not yield a representative sample. If this happens, do not sample the VMP. Similarly, if water is observed in the sampling line during purging, do not sample the VMP.
7. Attach tubing from the VMP to the flow controller on the Summa canister. All tubing used in this step should be rigid-walled Teflon or nylon tubing.
8. Open Summa canister valve completely and record the time.
9. Because of the half-hour sampling time, more than one location could be sampled at the same time (with staggered starting times).
10. After half-hour, or if the vacuum gauge reading drops below 5 inches Hg before a half-hour, close the Summa canister valve completely. Record the time. Vacuum gauge should not be allowed to drop below 2 inches of Hg.
11. Disconnect tubing from Summa Canister.
12. Remove the flow controller, attach the pressure gauge to the Summa canister, open valve completely, record reading, close valve completely, and remove the pressure gauge. There should still be a slight vacuum in the Summa canister.
13. If the canister does not show a significant net loss in vacuum after sampling, evaluate and document the problem. If necessary, contact the project manager immediately to determine the value of using another Summa canister to recollect the sample.
14. Connect tubing for a peristaltic pump to the VMP tubing to collect a sample in a Tedlar bag. Tedlar bag should be collected at a rate no faster than 200 ml/min.
15. From the soil vapor in the Tedlar bag obtain readings for CH<sub>4</sub>, CO<sub>2</sub>, and oxygen (O<sub>2</sub>) with a 4-gas meter. Record readings.
16. From the soil vapor in the Tedlar bag obtain readings for total volatile organics with a photoionization detector (PID) and/or flame ionization detector (FID). Record readings.
17. Disconnect tubing from VMP and discard.
18. Replace vapor point cover (if present) or, if it is a temporary sampling point, prepare the boring for abandonment.
19. Decontaminate any non-designated equipment (e.g., Swagelok connectors) following procedures in SOP No. 4.

#### 4. *Quality Control*

- For VMPs which are permanent installations, field duplicates are collected by attaching a T-fitting to the end of the tubing from the VMP. A Summa canister with a flow controller is attached to each end of the T-fitting. For sampling, both Summa canister valves are opened and closed simultaneously. Use the procedure described above to collect samples.
- As the duplicate method for VMPs only shows analytical variability, if sampling soil vapor through a temporary boring (e.g., Geoprobe<sup>®</sup>) the preferred method of duplicate sampling is to collect a duplicate from a second point approximately 2 meters from the initial point. If a second boring in the vicinity is not possible, proceed with the duplicate sampling method for VMPs.
- Additional leak detection practices may be required. One method of leak detection uses helium gas as a tracer and allows for the assessment of potential probe leaks prior to and during sample collection. The other method uses isopropyl alcohol as a tracer and allows for the assessment of potential probe leaks after sample collection analysis. Both of these methods are described in detail below:
  - Helium leak checking technique
    - i. Thread Teflon, or similar, tubing through the rubber grommet in the leak check enclosure from the outside, and attach the tubing to the vapor probe fitting. Slide the leak check enclosure down so that it seals on the ground. Attach the other end of the sample tubing to the sampling manifold
    - ii. Attach the tubing to the flow meter on the helium tank regulator and the other end to the enclosure. Attach the exhaust tubing to the enclosure and position the other end as far away as possible to avoid detection by the helium leak detector.
    - iii. Put the helium leak detector on the exhaust line from the sample pump. Turn on the sample pump and the helium detector.
    - iv. Open the helium tank and set the flow meter for approximately 200 mL/min. Allow it to flow for 1 minute to fill the leak check enclosure before starting sample collection.
    - v. During sampling, observed the helium detector for indication of probe leakage (e.g. infiltration of the helium into the probe). If a reading of >5% is observed, then the probe leak check has failed.

- vi. At the end of sampling, turn everything off. If >5% was observed on the helium detector, then check the fittings and try again. Record helium leak check values on field documentation.
- Isopropyl alcohol leak checking technique and purge
    - i. Moisten a paper towel with isopropyl alcohol. Wrap the moistened paper towel around probe fittings.
    - ii. It is important to keep the isopropyl alcohol completely away from the sample equipment and canister during the set up phase. It is also important to instruct the laboratory to analyze for isopropyl alcohol.
    - iii. If isopropyl alcohol is detected by the laboratory at a concentration greater than 5% (50,000 ppmv) then the sample is deemed to be invalid due to a leak.
  - Care should be taken so that no samples are collected in an area where vehicle or other equipment exhaust is being discharged.
  - Care should be taken with collected samples to keep Summa canisters safe from damage.

## 5. *Shipping*

- Samples shall be recorded on a chain of custody for the laboratory following procedures outlined in SOP No. 26.
- Samples will be shipped to the laboratory following DOT regulations. If there is the possibility that samples may be classified as hazardous, samples must be shipped as such. For procedures see SOP No. 24 and check with one of the office hazardous shipping personnel.

## **1. Objective**

This document defines the standard procedure for collection of groundwater samples using passive sampling or no-purge methodology. This procedure gives descriptions of equipment and field procedures necessary to collect groundwater samples. Other related SOPs are listed below:

- SOP No. 4 - Decontamination
- SOP No. 8 – Field Reporting and Documentation
- SOP No. 10 - Groundwater Level Measurements
- SOP No. 24 – Sample Classification, Packaging and Shipping (DOT)
- SOP No. 25 – Sample Containers, Preservation, and Holding Times
- SOP No. 26 – Sample Control and Custody Procedures
- SOP No. 33 - Water Quality Monitoring

## **2. Equipment**

Equipment used during well purging and sampling may include:

- Well keys
- Water level probe or Oil-water interface probe with 0.01-foot increments
- Assorted tools (knife, screwdriver, etc.)
- Collapsible no-purge sampler with VOC sampling tip
- Nylon rope
- Non-reactive weights for sampler (stainless steel or PVC)
- Down-hole Water Quality Parameter Instrument – measures pH, temperature, conductivity, turbidity, dissolved oxygen, and/or oxidation-reduction potential
- Plastic squeeze or spray bottle filled with distilled water
- Paper towels or Kimwipes
- Calculator
- Field notebook

- Waterproof and permanent marker
- Plastic 5-gallon bucket(s) or truck-mounted poly-tank
- 55-gallon drums or frac tank
- Plastic sheeting (for placing around well)
- Appropriate health and safety equipment
- Well completion information sheet
- Appropriate decontamination equipment
- Cooler with ice
- Field Sampling Data Sheet
- Sample jars and labels. Sample bottles with preservatives added will be obtained from the analytical laboratory. Several extra sample bottles will be obtained in case of breakage or other problems.

### 3. *Sampler Placement Procedures*

This section provides the step-by-step procedures for placing the no-purge groundwater sampler. The procedures are specific to sampling using the HydraSleeve® samplers. The proper size sample sleeve should be chosen based on the well diameter and the volume required for filling the required sample bottles. Standard HydraSleeves® are available for 2-inch and 4-inch diameter wells, with lengths from 30 to 36 inches; however custom sizes are available upon request.

Observations made should be recorded in the field notebook in accordance with procedures described in SOP No. 8 on field reporting and documentation and on the groundwater sampling data sheet provided as Attachment 1 of this SOP.

- A. Before any sampling begins, all non-dedicated well probes and other non-disposable sampling devices shall be decontaminated. If dedicated equipment is used, it should be rinsed with distilled water. Mobile decontamination supplies should be provided so that equipment can be decontaminated in the field.
- B. Before placing the sampler in the well, the following procedures will be performed at each well:

- 1) The condition of the outer well casing, concrete well pad, protective posts (if present), and any unusual conditions of the area around the well will be noted in the field logbook.
  - 2) The well will be opened.
  - 3) Appropriate readings will be taken in the breathing zone with a flame ionization detector (FID) or photoionization detector (PID) according to the Health and Safety Plan. The reading will be recorded in the field logbook
  - 4) The condition of the inner well cap and casing will be noted.
- C. Groundwater elevations will be measured to the nearest 1/100 foot at each monitoring well using an electronic water level indicator or an oil-water interface probe.
- D. If a non-aqueous phase liquid (NAPL) is identified, its thickness will be measured. The presence of light or dense NAPLs may preclude sampling of the groundwater itself.
- E. Measure out length of nylon rope appropriate for depth of no-purge sampler. Be sure to leave additional rope for attaching sleeve, knots, and to allow manipulation (raising/lowering) of sampler.
- F. Prepare sampling sleeve for deployment using the following steps:
- 1) Remove sleeve from packaging.
  - 2) Grasp top to pop open.
  - 3) Squeeze side fins together to bend reinforcing strips out.
  - 4) Attach nylon line to hole at top of sleeve
  - 5) Attach weight and/or additional sleeve(s) through both holes at bottom of sleeve.
  - 6) Attach weight to nylon rope at top of sleeve (optional).
- G. Lower sampler assembly to desired depth within the well at a **slow** and **gentle** pace in order to minimize agitation. If sampler height needs to be adjusted upwards, pull rope at a rate of less than 0.5 ft per second in order to keep sampler from activating. The sleeve should be positioned such that the sample will be collected from the known source of contamination within the screened interval or the midpoint of the well screen. The total

upward distance the check valve must travel to fill the sample sleeve is about 1 to 2 times the length of the sampler.

H. Leave sampler in well until well re-equilibrates (24 hours minimum).

#### 4. *Sample Collection Procedures*

This section provides the step-by-step procedures for collecting samples from the no-purge groundwater sampler after the wells have reached equilibrium. Observations made should be recorded in the field notebook in accordance with procedures described in SOP No. 8 on field reporting and documentation and on the groundwater sampling data sheet provided as Attachment 1 of this SOP.

A. Identification labels for sample bottles will be filled out for each well.

B. Before retrieving the sampler in the well, the following procedures will be performed at each well:

- Any changes to the condition of the outer well casing, concrete well pad, protective posts (if present), and any unusual conditions of the area around the well will be noted in the field logbook.
- The well will be opened.
- Appropriate readings will be taken in the breathing zone with a flame ionization detector (FID) or photoionization detector (PID) according to the Health and Safety Plan. The reading will be recorded in the field logbook

C. Groundwater elevations will be measured to the nearest 1/100 foot at each monitoring well using an electronic water level indicator or an oil-water interface probe.

D. The sampler will be activated and retrieved utilizing one of the following methods:

- **Continuous** – Pull the sampler in one smooth continuous pull. Rate of pull should be between 1 to 2 feet per second. (This is the least turbid method and is analogous to coring the water column from the bottom up.)
- **Short Strokes** – Pull the sampler up to the length of the sampler then smoothly drop the sampler back to the starting point. Repeat this three to five times to fill the sleeve. Rate of each pull stroke should be between 1 to 2 feet per second.

(This provides a shorter sampling interval, and the sample comes from between the top of the cycle and the bottom of the sampler at its lowest point.)

- **Rapid, Short Cycles** – Rapidly cycle the sample sleeve up and down using short 6-inch cycles. Repeat this five to eight times to fill the sleeve. A minimum of one 6-inch cycle should be completed per second. (This provides the shortest sampling interval, and the sample comes from between the top of the check valve at the peak of the cycle and the bottom of the sampler at its lowest point in the cycle.)
  - **Low-Yield** – This method utilizes a top weight on the sleeve to compress the sampler in the bottom of the well. As the sampler is pulled up, the sleeve will uncompress and fill from the top of the sampler. Rate of pull should be between 1 to 2 feet per second. (This will collect a water core from the top of the sampler to about its own length above that point.)
- E. Once the sleeve is removed from the well, **slowly** and **gently** lower the down-hole water quality parameter instrument to the sample collection depth within the well.
- F. Squeeze the full sampler just below the top to expel water resting above the flexible check valve.
- G. Puncture sampler about three to four inches below the reinforcing strips with the sampling straw from the kit.
- H. The individual sample bottles should be filled using the discharge tube in the order given below:
- Volatile organic compounds (VOCs)
  - Semivolatiles organic compounds, pesticides and PCBs, and herbicides
  - Petroleum hydrocarbons
  - Total metals
  - Explosives
- I. Time of sampling will be recorded in the field book and on the groundwater sampling data sheet.

- J. Once the sample bottles have been filled, watch for the water quality parameters to stabilize. Record the stabilized parameter readings on the groundwater sampling data sheet.
- K. Remove the down-hole water quality parameter instrument from the well.
- L. Replace the well cap and lock the well cap/casing.
- M. A field groundwater sampling data sheet for groundwater samples (Attachment 1) will be completed at each sampling location. The data sheet will be completely filled in. If items on the sheet do not apply to a specific location, the item will be labeled as not applicable (NA).
- N. Place the sample containers on ice in a cooler to maintain the samples at approximately 4 °C as described in SOP No. 25. Ship the cooler to the laboratory for analysis within the appropriate time in accordance with procedures described in SOP No. 24.
- O. Begin chain-of-custody procedures. A sample chain-of-custody form is included in SOP No. 26.

Any excess water from the sample sleeves should be collected in a 5-gallon bucket, poly-tank or similar, or in accordance with the project plan.

#### **5. *Decontamination***

Small non-disposable equipment will be cleaned using the following equipment procedures (additional decontamination procedures are described in SOP No. 4, if needed):

- A. Rinse with non-potable water to remove the gross contamination
- B. Scrub or wipe using Alconox soap (or equivalent) and distilled water solution
- C. Wipe off using isopropyl alcohol
- D. Rinse with distilled water

Any water accumulated during decontamination should be collected in a 5-gallon bucket, poly-tank or similar, or in accordance with the project plan.

## GROUNDWATER SAMPLING DATA SHEET

PROJECT NAME: \_\_\_\_\_ PROJECT NUMBER: \_\_\_\_\_  
 DATE: \_\_\_\_\_  
 WEATHER: \_\_\_\_\_  
 FIELD PERSONNEL: \_\_\_\_\_  
 MONITORING WELL ID: \_\_\_\_\_

### INITIAL DATA

Well Diameter: \_\_\_\_\_ in. Gallons/Lin.Ft<sup>1</sup>: \_\_\_\_\_ Ambient PID/FID Reading: \_\_\_\_\_ ppm  
 Total Depth of Well: \_\_\_\_\_ ft Vol. Of Water Column: \_\_\_\_\_ gallons Wellbore PID/FID Reading: \_\_\_\_\_ ppm  
 Depth to Water: \_\_\_\_\_ ft Volume Of Water Introduced From Drilling: \_\_\_\_\_ gallons LNAPL / DNAPL \_\_\_\_\_ ft  
 Height of Water Column: \_\_\_\_\_ ft Min. Purge Volume: \_\_\_\_\_ gallons (\_\_\_\_ volumes)  
 Depth to Top of Screen: \_\_\_\_\_ ft

1 0.163 gallons/ft for 2 inch well, 0.653 gallons/ft for 4-inch well

### GROUNDWATER QUALITY DATA

Data Collection Method: \_\_\_\_\_

Purge Volume (gals)	Time	Depth to Water (ft)	Color	Odor	pH	Temp (°C)	Cond. (ms/cm)	Turbidity (NTUs)	DO (mg/l)	ORP (mv)

Start Time: \_\_\_\_\_ Purge Stop Time: \_\_\_\_\_ Elapsed Time: \_\_\_\_\_ Total Volume Purged: \_\_\_\_\_ gallons  
 Average Purge Rate (gallons/min): \_\_\_\_\_ Well Volumes Purged: \_\_\_\_\_ Water Quality Meter ID: \_\_\_\_\_ Calibrated on: \_\_\_\_\_

### SAMPLING DATA

Sampling Method: \_\_\_\_\_  
 Sample Date: \_\_\_\_\_ Sample Time: \_\_\_\_\_ Analysis: \_\_\_\_\_

COMMENTS:  
 \_\_\_\_\_  
 \_\_\_\_\_  
 \_\_\_\_\_





# HYDRASleeve

Simple by Design

US Patents No. 6,481,300; No. 6,837,120; others pending

## Field Manual

# Introduction

The HydraSleeve groundwater sampler can be used to collect a representative sample for most physical and chemical parameters without purging the well. It collects a whole water sample from a user-defined interval (typically within the well screen), without mixing fluid from other intervals. One or more HydraSleeves are placed within the screened interval of the monitoring well, and a period of time is allocated for the well to re-equilibrate. Hours to months later, the sealed HydraSleeve can be activated for sample collection. When activated, HydraSleeve collects a sample with no drawdown and minimal agitation or displacement of the water column. Once the sampler is full, the one-way reed valve collapses, preventing mixing of extraneous, non-representative fluid during recovery.

## Assembly

Assembling the HydraSleeve is simple, and can be done by one person in the field, taking only a minute or two.

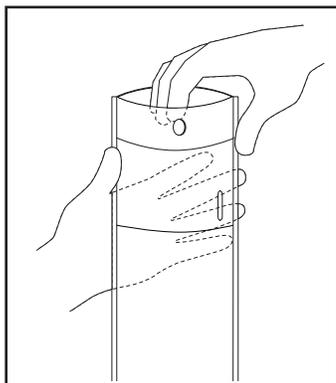

**1** Remove HydraSleeve from package and grasp top to "pop" open.

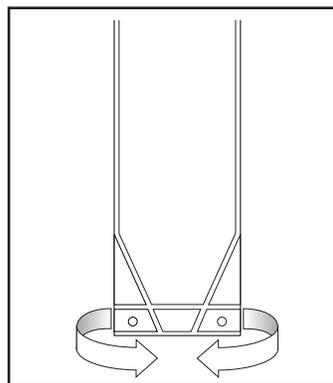

**4** Fold the two holes at bottom of HydraSleeve together and attach weight

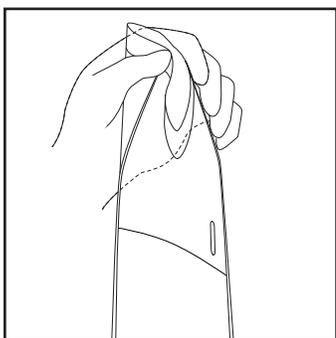

**2** Squeeze side fins together at top to bend reinforcing strips outward.

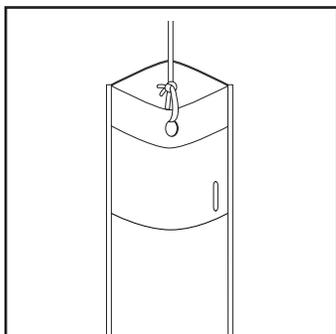

**3** Attach line to hole at top of HydraSleeve.

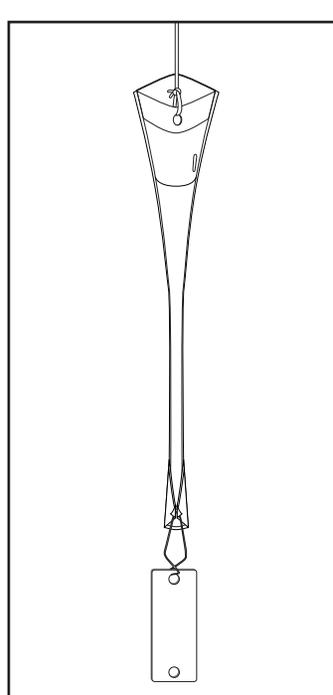

**5** Sampler is ready to insert into the well.

# Placing the HydraSleeve(s)

To collect a representative groundwater sample without purging, the well must be allowed time to re-equilibrate after placement of the sampler. When any device is lowered into a well, some mixing of the water column occurs. The diameter of the device and its shape greatly affect the degree of mixing. The flat cross-section of the empty HydraSleeve minimizes the disturbance to the water column as the sampler is lowered into position, reducing the time needed for the well to return to equilibrium.

There are three basic methods for holding a HydraSleeve in position as the well equilibrates.

## TOP DOWN DEPLOYMENT (Figure 1)

Measure the correct amount of suspension line needed to "hang" the top of the HydraSleeve(s) at the desired sampling depth (in most cases, this will be at the bottom of the sampling zone). The upper end of the tether can be connected to the well cap to suspend the HydraSleeve at the correct depth until activated for sampling.

Note: For deep settings, it may be difficult to accurately measure long segments of suspension line in the field. Factory prepared, custom suspension line and attachment points can be provided.

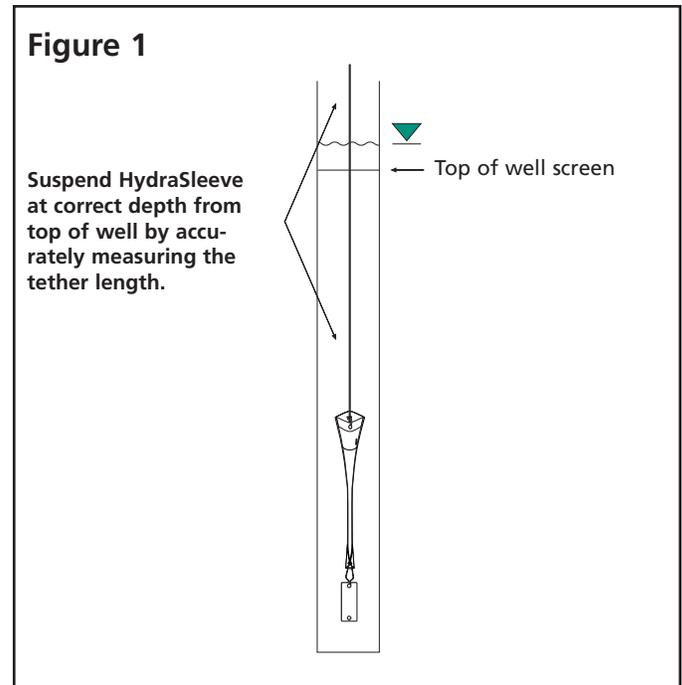

## BOTTOM DEPLOYMENT (Figure 2)

Sound the well to determine the exact depth. Lower the weighted HydraSleeve into the well and let it touch the bottom. Very slowly (less than 1/2 foot per second) raise the sampler to the point where the check valve is at the depth the sample is to be collected. Attach the suspension line to the top of the well to suspend it at this depth. (It is often easier to measure a few feet from the bottom of the well up to the sample point, than it is to measure many feet from the top of the well down.)

Alternately, the sampler can be left on the bottom until the well re-equilibrates. For sampling, it can be very slowly pulled (< 1/2 fps) to sampling depth, then activated (see "Sample Collection," p. 6) to collect the sample, and retrieved to the surface.

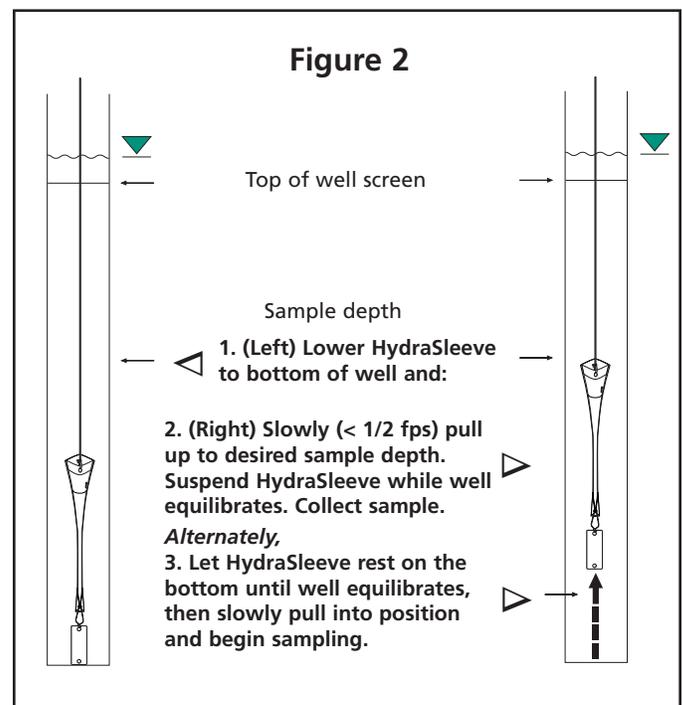

### BOTTOM ANCHOR (Figure 3)

Determine the exact depth of the well.  
Calculate the distance from the bottom of the well to the desired sampling depth.  
Attach an appropriate length anchor line between the weight and the bottom of the sampler and lower the assembly until the weight rests on the bottom of the well, allowing the top of the sampler to float at the correct sampling depth.

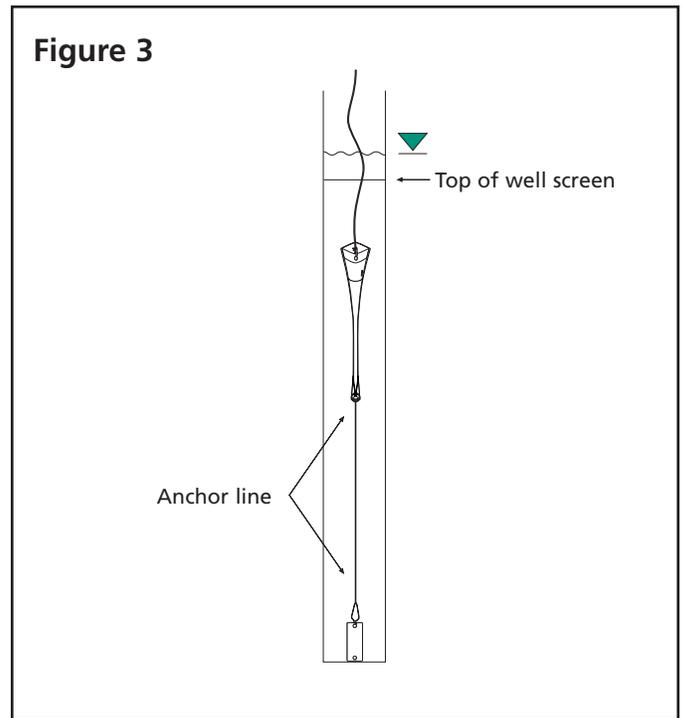

# Multiple Interval Deployment

There are two basic methods for placing multiple HydraSleeves in a well to collect samples from different levels simultaneously.

## ATTACHED TO A SINGLE TETHER (Figure 4)

To use 3 or more samplers simultaneously, we recommend attaching them all to a tether for support to prevent the sampling string from pulling apart. The weight is attached to a single length of suspension line and allowed to rest on the bottom of the well. The top and bottom of each HydraSleeve are attached to the tether at the desired sample intervals. Cable tie or stainless steel clips (supplied) work well for attaching the HydraSleeves to the line. Simply push one end of the clip between strands of the rope at the desired point before attaching the clip to the HydraSleeve.

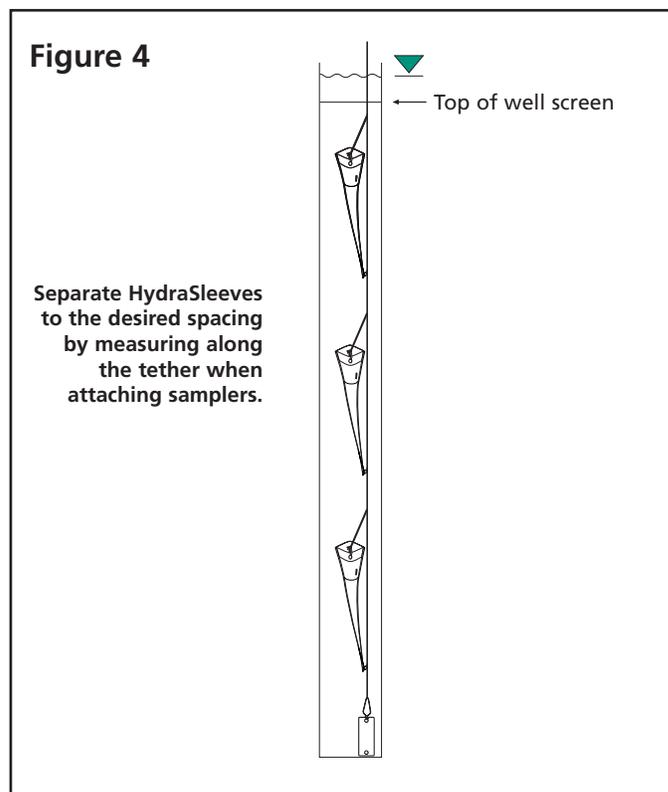

## ATTACHED END TO END (Figure 5)

To place 2 or 3 stacked HydraSleeves for vertical profiling, use one of the methods described above to locate the bottom sampler. Attach the bottom of the top sampler to the top of the following HydraSleeve(s) with a carefully measured length of suspension cable. Connect the weight to the bottom sampler. Note: if many HydraSleeves are attached to a tether, more weight may be required than with a single sampler.

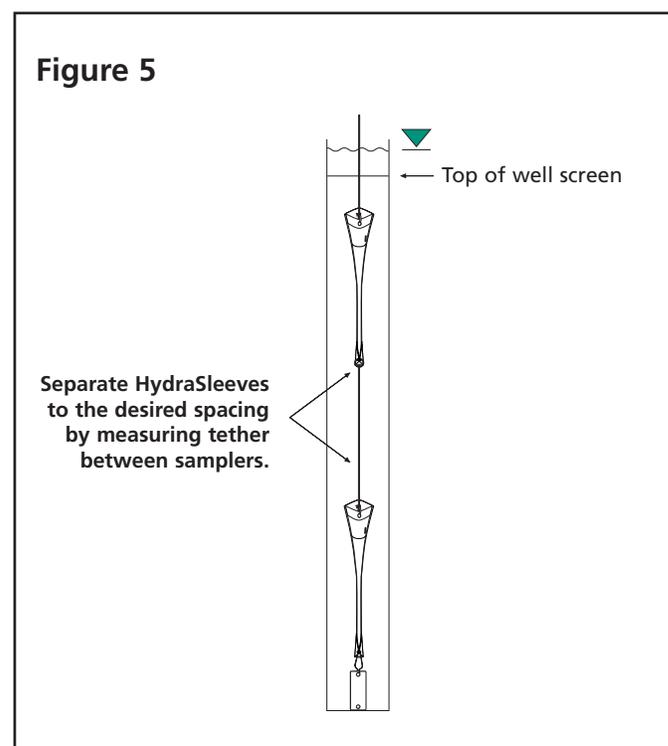

# Sample Collection

The HydraSleeve must move upward at a rate of one foot per second or faster (about the speed a bailer is usually pulled upward) for water to pass through the check valve into the sample sleeve. The total upward distance the check valve must travel to fill the sample sleeve is about 1 to 2 times the length of the sampler. For example, a 24-inch HydraSleeve needs a total upward movement of 24 to no more than 48 inches to fill. The upward motion can be accomplished using one long continuous pull, several short strokes, or any combination that moves the check valve the required distance in the open position. A special technique is used for sampling low-yield wells.

## CONTINUOUS PULL (Figure 6)

Pull the HydraSleeve continuously upward from its starting point at a constant 1 to 2 feet per second until full. This method usually provides the least turbid samples and is analogous to coring the water column from the bottom up.

*Note: When using this method, the screen interval should be long enough so the sampler fills before exiting the top of the screen.*

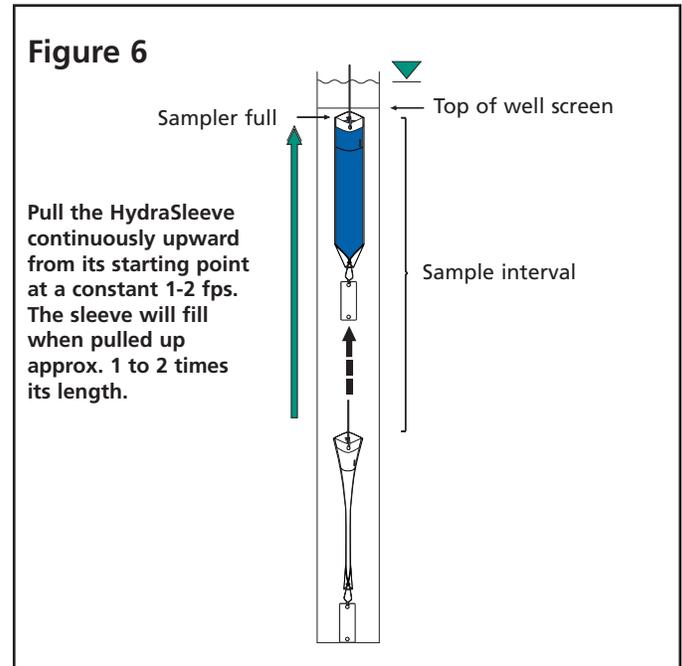

## SHORT STROKES (Figure 7)

Pull the sampler upward at about 1 to 2 feet per second for the length of the sampler and let it drop back to the starting point. Repeat the cycle 3 to 5 times.

This method provides a shorter sampling interval than the continuous pull method (above), and usually reduces the turbidity levels of the sample below that of numerous rapid, short cycles (below). The sample comes from between the top of the cycle and the bottom of the sampler at its lowest point.

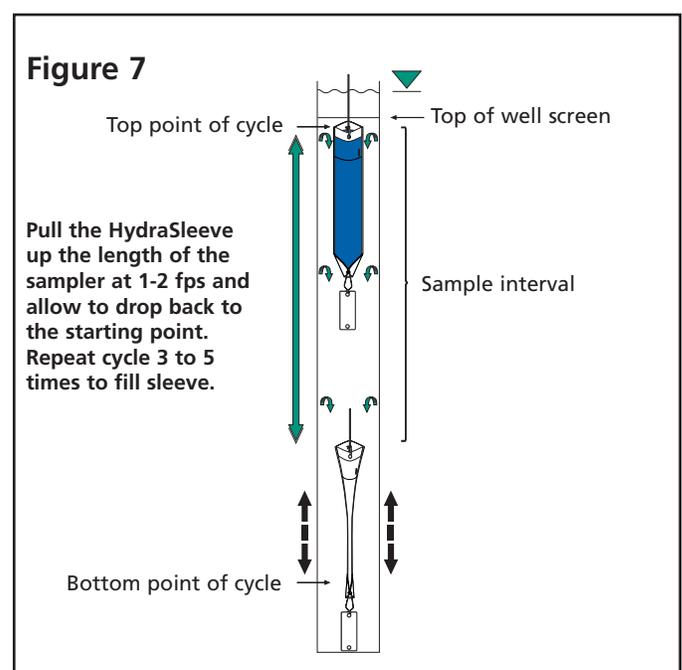

## RAPID, SHORT CYCLES (Figure 8)

Cycle the HydraSleeve up and down using rapid, short strokes (6-inch cycle at a minimum of 1 cycle per second) 5 to 8 times. This method provides the shortest sampling interval. Dye studies have shown that when using this method the sample flows into the check valve from along the length of the sampler and immediately above the check valve. The sample interval is from the bottom the sampler at its lowest point in the cycle to the top of the check valve at the peak of the cycle.

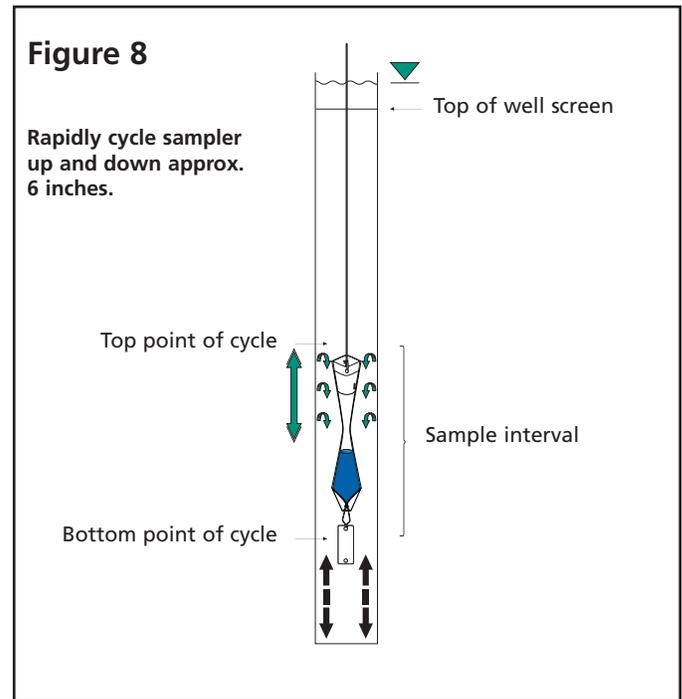

## SAMPLING LOW-YIELD WELLS (Figure 9)

HydraSleeve provides the best available technology for sampling low yield wells. When pulled upward after the well re-equilibrates, the HydraSleeve will collect a water core from the top of the sampler to about its own length above that point. The sample is collected with no drawdown in the well and minimal sample agitation. An optional top weight can be attached to compress the sampler in the bottom of the well if needed for an extremely short water column. With a top weight, the check valve is pushed down to within a foot of the bottom of the well.

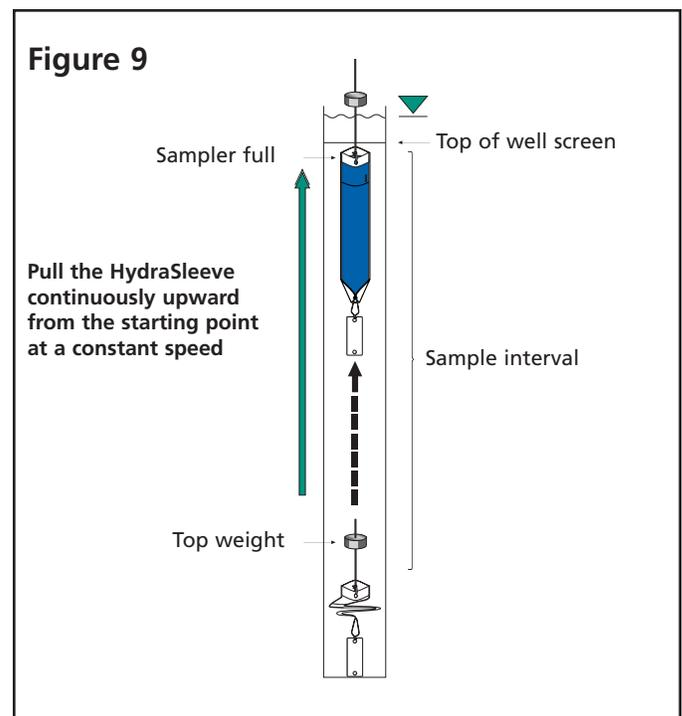

# Sample Discharge

The best way to remove a sample from the HydraSleeve with the least amount of aeration and agitation is with the short plastic discharge tube (included).



First, squeeze the full sampler just below the top to expel water resting above the flexible check valve. (Photo 1, top left)



Then, push the pointed discharge tube through the outer polyethylene sleeve about 3-4 inches below the white reinforcing strips. (Photo 2, middle left)



Discharge the sample into the desired container. (Photo 3, bottom left)

Raising and lowering the bottom of the sampler or pinching the sample sleeve just below the discharge tube will control the flow of the sample. The sample sleeve can also be squeezed, forcing fluid up through the discharge tube, similar to squeezing a tube of toothpaste. With a little practice, and using a flat surface to set the sample containers on, HydraSleeve sampling becomes a one-person operation.



1680 Hickory Loop, Suite B • Las Cruces, NM 88005  
Phone: 1.800.996.2225 • 1.505.523.5799 • Fax: 1.505.523.0789  
[www.geoinsightonline.com](http://www.geoinsightonline.com) • [KentCordry@aol.com](mailto:KentCordry@aol.com)